

MANUFAKTUR FEINSTER UHRENARMBÄNDER | MANUFACTURERS OF EXCLUSIVE WATCH STRAPS

RIOS1931

RIEMER OSWALD





R10S1931

R10S1931

STAINLESS

Inhalt

SEITE
PAGE

Contents

<i>Seite / Familie</i>	4	<i>Page / Family</i>
<i>Modellnummer</i>	10	<i>Model number</i>
<i>RIOS1931 – Oswald Riemer</i>	16	<i>RIOS1931 – Oswald Riemer</i>
<i>Deutscher Qualitätsstandard</i>	18	<i>German quality standard</i>
<i>Traditionelle Manufaktur</i>	20	<i>Traditional manufacture</i>
<i>Handwerkskunst</i>	22	<i>Craftsmanship</i>
<i>Die RIOS1931 Handnaht</i>	24	<i>The RIOS1931 Saddler's Seam</i>
<i>Unsere Handnaht</i>	26	<i>Our Saddler's Seam</i>
<i>Fertigungsarten</i>	28	<i>Manufacturing methods</i>
<i>172 Arbeitsschritte</i>	32	<i>172 Working steps</i>
<i>Art Manuel</i>	36	<i>Art Manuel</i>
<i>Symbole</i>	37	<i>Symbols</i>
<i>Partner des Uhrenfachhandels</i>	38	<i>Partner to watch retailers</i>
<i>Mehrwerte</i>	40	<i>Added value</i>
<i>Partner der Uhrenindustrie</i>	42	<i>Partner to the watch industry</i>
<i>Gesundheit und Artenschutz</i>	44	<i>Health and Protection of Species</i>
<i>Reptilien / Exoten</i>	46	<i>Reptiles / Exotics</i>
<i>Bio</i>	58	<i>Organic</i>
<i>Juchten / Shell Cordovan</i>	70	<i>Russia Leather / Shell Cordovan</i>
<i>Kalb / Rind / Sattelleder</i>	76	<i>Calf / Cow / Saddle Leather</i>
<i>Büffel / Lamm / Schwein</i>	86	<i>Buffalo / Lamb / Pig</i>
<i>Prägung</i>	94	<i>Embossed Leather</i>
<i>Vintage / Velours / Canvas</i>	106	<i>Vintage / Suede / Canvas</i>
<i>Wasserresistent</i>	124	<i>Water resistant</i>
<i>Nato- / Durchzugsbänder</i>	134	<i>Nato Straps / One-Piece Straps</i>
<i>Ersatzbänder</i>	144	<i>Replacement Straps</i>
<i>Accessoires</i>	170	<i>Accessories</i>
<i>Verkaufshilfen</i>	178	<i>Display Options</i>
<i>Schließen</i>	182	<i>Clasps</i>
<i>Werkzeuge und Extras</i>	184	<i>Tools and Extras</i>
<i>Schließen</i>	185	<i>Clasps</i>
<i>Farbübersicht Echt Alligator</i>	188	<i>Colour Palette Genuine Alligator</i>
<i>Farbübersicht</i>	190	<i>Colour Palette</i>
<i>Richtig bestellen</i>	192	<i>How to order</i>
<i>RIOS1931 Einhängesystem</i>	193	<i>RIOS1931 Easy clasp system</i>
<i>Bestellschein für Sonderanfertigungen</i>	194	<i>Order form for custom-made goods</i>

Seite 46 Reptilien / Exoten

47	Mod. 277	Windsor	Echt Alligatorenleder in glanz, Fullcut
47	Mod. 276	President	Echt Alligatorenleder in matt, Fullcut
48	Mod. 273	Premier	Echt Alligatorenleder in glanz, Fullcut
48	Mod. 272	Senator	Echt Alligatorenleder in matt, Fullcut
49	Mod. 270	Imperator	Echt Alligatorenleder in matt, Fullcut
49	Mod. 266	Monarch	Echt Alligatorenleder in matt, Fullcut
50	Mod. 256	Connoisseur	Echt Alligatorenleder in matt, Fullcut
50	Mod. 252	Superior	Echt Alligatorenleder in matt, Flank
51	Mod. 250	Ambassador	Echt Alligatorenleder in matt, Flank
51	Mod. 249	Heritage	Echt Alligatorenleder in glanz, Flank
52	Mod. 248	Imperial	Echt Alligatorenleder in matt, Flank
52	Mod. 245	Brilliant	Echt Alligatorenleder in glanz, Flank
53	Mod. 244	Prestige	Echt Alligatorenleder in matt, Flank
53	Mod. 241	Royal	Echt Alligatorenleder in matt, Flank
54	Mod. 240	Lord	Echt Krokodilleder in glanz
54	Mod. 230	Maison	Echt Strauenleder
55	Mod. 222	Avenue	Echt Teju-Eidechsenleder in glanz
55	Mod. 220	Allure	Echt Eidechsenleder in glanz
56	Mod. 218	Charme	Echt Eidechsenleder in glanz
56	Mod. 210	Wave	Echt Haifischleder

Seite 62 Bio

63	Mod. 433	Starnberg	Echt zertifiziertes Bioleder
63	Mod. 432	Tegernsee	Echt zertifiziertes Bioleder
64	Mod. 429	Weilheim	Echt zertifiziertes Bioleder
64	Mod. 428	Garmisch	Echt zertifiziertes Bioleder
65	Mod. 427	Sonthofen	Echt zertifiziertes Bioleder
65	Mod. 423	Landsberg	Echt zertifiziertes Bioleder
66	Mod. 420	Schongau	Echt zertifiziertes Bioleder
66	Mod. 416	Fssen	Echt zertifiziertes Bioleder
67	Mod. 412	Peiting	Echt zertifiziertes Bioleder
67	Mod. 408	Waging	Echt zertifiziertes Bioleder
68	Mod. 405	Inzell	Echt zertifiziertes Bioleder
68	Mod. 404	Mittenwald	Echt zertifiziertes Bioleder
69	Mod. 400	Kempton	Echt zertifiziertes Bioleder

Seite 70 Juchten / Shell Cordovan

71	Mod. 205	Kaluga	Echt Juchtenleder
71	Mod. 204	Tula	Echt Juchtenleder mit Uhren-Lederunterlage
72	Mod. 203	Pensa	Echt Juchtenleder
72	Mod. 202	Samara	Echt Juchtenleder
73	Mod. 201	St. Petersburg	Echt Juchtenleder
73	Mod. 200	Moscow	Echt Juchtenleder
74	Mod. 199	New York	Echt Shell Cordovan Leder
74	Mod. 198	Chicago	Echt Shell Cordovan Leder
75	Mod. 193	Seattle	Echt Shell Cordovan Leder

Page 46 Reptiles / Exotics

47	Mod. 277	Windsor	Genuine Alligator Leather, glossy finish, fullcut
47	Mod. 276	President	Genuine Alligator Leather, matt finish, fullcut
48	Mod. 273	Premier	Genuine Alligator Leather, glossy finish, fullcut
48	Mod. 272	Senator	Genuine Alligator Leather, matt finish, fullcut
49	Mod. 270	Imperator	Genuine Alligator Leather, matt finish, fullcut
49	Mod. 266	Monarch	Genuine Alligator Leather, matt finish, fullcut
50	Mod. 256	Connoisseur	Genuine Alligator Leather, matt finish, fullcut
50	Mod. 252	Superior	Genuine Alligator Leather, matt finish, flank
51	Mod. 250	Ambassador	Genuine Alligator Leather, matt finish, flank
51	Mod. 249	Heritage	Genuine Alligator Leather, glossy finish, flank
52	Mod. 248	Imperial	Genuine Alligator Leather, matt finish, flank
52	Mod. 245	Brilliant	Genuine Alligator Leather, glossy finish, flank
53	Mod. 244	Prestige	Genuine Alligator Leather, matt finish, flank
53	Mod. 241	Royal	Genuine Alligator Leather, matt finish, flank
54	Mod. 240	Lord	Genuine Crocodile Leather, glossy finish
54	Mod. 230	Maison	Genuine Ostrich Leather
55	Mod. 222	Avenue	Genuine Teju Lizard Leather, glossy finish
55	Mod. 220	Allure	Genuine Lizard Leather, glossy finish
56	Mod. 218	Charme	Genuine Lizard Leather, glossy finish
56	Mod. 210	Wave	Genuine Shark Leather

Page 62 Organic

63	Mod. 433	Starnberg	Genuine Certified Organic Leather
63	Mod. 432	Tegernsee	Genuine Certified Organic Leather
64	Mod. 429	Weilheim	Genuine Certified Organic Leather
64	Mod. 428	Garmisch	Genuine Certified Organic Leather
65	Mod. 427	Sonthofen	Genuine Certified Organic Leather
65	Mod. 423	Landsberg	Genuine Certified Organic Leather
66	Mod. 420	Schongau	Genuine Certified Organic Leather
66	Mod. 416	Fssen	Genuine Certified Organic Leather
67	Mod. 412	Peiting	Genuine Certified Organic Leather
67	Mod. 408	Waging	Genuine Certified Organic Leather
68	Mod. 405	Inzell	Genuine Certified Organic Leather
68	Mod. 404	Mittenwald	Genuine Certified Organic Leather
69	Mod. 400	Kempton	Genuine Certified Organic Leather

Page 70 Russia Leather / Shell Cordovan

71	Mod. 205	Kaluga	Genuine Russia Leather
71	Mod. 204	Tula	Genuine Russia Leather with watch leather underlay
72	Mod. 203	Pensa	Genuine Russia Leather
72	Mod. 202	Samara	Genuine Russia Leather
73	Mod. 201	St. Petersburg	Genuine Russia Leather
73	Mod. 200	Moscow	Genuine Russia Leather
74	Mod. 199	New York	Genuine Shell Cordovan Leather
74	Mod. 198	Chicago	Genuine Shell Cordovan Leather
75	Mod. 193	Seattle	Genuine Shell Cordovan Leather

Seite 76 Kalb / Rind / Sattelleder

77	Mod. 138	Apulia	Echt Kalbsleder
77	Mod. 137	Veneto	Echt Kalbsleder
78	Mod. 135	Maranello	Echt Kalbsleder
78	Mod. 104	Capri	Echt Kalbsleder
79	Mod. 102	Toscana	Echt Kalbsleder
79	Mod. 68	Nevada	Echt Sattelleder
80	Mod. 54	California Sport	Echt Sattelleder
80	Mod. 46	Arizona	Echt Sattelleder
81	Mod. 46S	Arizona »mit Spange«	Echt Sattelleder
81	Mod. 45	French	Echt Rindsleder
82	Mod. 44	Smart	Echt Rindsleder
82	Mod. 43	Elegant	Echt Rindsleder
83	Mod. 41	Solid	Echt Rindsleder
83	Mod. 34	Classic	Echt Rindsleder
84	Mod. 30S	Diplomat »mit Spange«	Echt Rindsleder
84	Mod. 21	Racing	Echt Rindsleder mit Racinglöchern
85	Mod. 20	Ecco	Echt Rindsleder

Seite 86 Büffel / Lamm / Schwein

87	Mod. 209	Aviator	Echt Büffelleder
87	Mod. 207	Performance	Echt Büffelleder
88	Mod. 206	Advantage	Echt Büffelleder
88	Mod. 65	Montana	Echt Büffelleder
89	Mod. 64	Colorado	Echt Büffelleder
89	Mod. 61	Nature	Echt Büffelleder
90	Mod. 62	Texas	Echt Büffelleder
90	Mod. 55	Cashmere	Echt Lammleder
91	Mod. 47	Merino	Echt Lammleder
91	Mod. 39	Havana	Echt Schweinsleder
92	Mod. 38	Tobacco	Echt Schweinsleder

Seite 94 Prägung

95	Mod. 70	Brazil	Krokodilnarbung auf echt Rindsleder geprägt
95	Mod. 60	Ocean	Haifischnarbung auf echt Rindsleder geprägt
96	Mod. 59	Vegas	Alligatorenarbung auf echt Rindsleder geprägt
96	Mod. 58	Baltimore	Alligatorenarbung auf echt Rindsleder geprägt
97	Mod. 57	Boston	Alligatorenarbung auf echt Rindsleder geprägt
97	Mod. 56	Dallas	Alligatorenarbung auf echt Rindsleder geprägt
98	Mod. 53	Panama	Alligatorenarbung auf echt Rindsleder geprägt
98	Mod. 52	Orlando	Alligatorenarbung auf echt Rindsleder geprägt
99	Mod. 51	New Orleans	Alligatorenarbung auf echt Rindsleder geprägt
99	Mod. 50	Louisiana	Alligatorenarbung auf echt Rindsleder geprägt
100	Mod. 49	Argentina	Alligatorenarbung auf echt Rindsleder geprägt
100	Mod. 49S	Argentina »mit Spange«	Alligatorenarbung auf echt Rindsleder geprägt
101	Mod. 48	Durban	Straußennarbung auf echt Rindsleder geprägt
101	Mod. 42	Bolivia	Teju-Eidechsenarbung auf echt Rindsleder geprägt

Page 76 Calf / Cow / Saddle Leather

77	Mod. 138	Apulia	Genuine Calfskin
77	Mod. 137	Veneto	Genuine Calfskin
78	Mod. 135	Maranello	Genuine Calfskin
78	Mod. 104	Capri	Genuine Calfskin
79	Mod. 102	Toscana	Genuine Calfskin
79	Mod. 68	Nevada	Genuine Saddle Leather
80	Mod. 54	California Sport	Genuine Saddle Leather
80	Mod. 46	Arizona	Genuine Saddle Leather
81	Mod. 46S	Arizona »with clasp«	Genuine Saddle Leather
81	Mod. 45	French	Genuine Cowhide
82	Mod. 44	Smart	Genuine Cowhide
82	Mod. 43	Elegant	Genuine Cowhide
83	Mod. 41	Solid	Genuine Cowhide
83	Mod. 34	Classic	Genuine Cowhide
84	Mod. 30S	Diplomat »with clasp«	Genuine Cowhide
84	Mod. 21	Racing	Genuine Cowhide with racing holes
85	Mod. 20	Ecco	Genuine Cowhide

Page 86 Buffalo / Lamb / Pig

87	Mod. 209	Aviator	Genuine Buffalo Leather
87	Mod. 207	Performance	Genuine Buffalo Leather
88	Mod. 206	Advantage	Genuine Buffalo Leather
88	Mod. 65	Montana	Genuine Buffalo Leather
89	Mod. 64	Colorado	Genuine Buffalo Leather
89	Mod. 61	Nature	Genuine Buffalo Leather
90	Mod. 62	Texas	Genuine Buffalo Leather
90	Mod. 55	Cashmere	Genuine Lambskin
91	Mod. 47	Merino	Genuine Lambskin
91	Mod. 39	Havana	Genuine Pigskin
92	Mod. 38	Tobacco	Genuine Pigskin

Page 94 Embossed Leather

95	Mod. 70	Brazil	Embossed Crocodile Grain on Genuine Cow Leather
95	Mod. 60	Ocean	Embossed Shark Grain on Genuine Cow Leather
96	Mod. 59	Vegas	Embossed Alligator Grain on Genuine Cow Leather
96	Mod. 58	Baltimore	Embossed Alligator Grain on Genuine Cow Leather
97	Mod. 57	Boston	Embossed Alligator Grain on Genuine Cow Leather
97	Mod. 56	Dallas	Embossed Alligator Grain on Genuine Cow Leather
98	Mod. 53	Panama	Embossed Alligator Grain on Genuine Cow Leather
98	Mod. 52	Orlando	Embossed Alligator Grain on Genuine Cow Leather
99	Mod. 51	New Orleans	Embossed Alligator Grain on Genuine Cow Leather
99	Mod. 50	Louisiana	Embossed Alligator Grain on Genuine Cow Leather
100	Mod. 49	Argentina	Embossed Alligator Grain on Genuine Cow Leather
100	Mod. 49S	Argentina »with clasp«	Embossed Alligator Grain on Genuine Cow Leather
101	Mod. 48	Durban	Embossed Ostrich Grain on Genuine Cow Leather
101	Mod. 42	Bolivia	Embossed Teju Lizard Grain on Gen. Cow Leather

Seite	Prägung		
102	Mod. 37	Hollywood	Alligatorennarbung auf echt Rindsleder geprägt
102	Mod. 36	Monza	Carbonlook auf echt Rindsleder geprägt
103	Mod. 35	Miami	Alligatorennarbung auf echt Rindsleder geprägt
103	Mod. 33	Silverstone	Carbonlook auf echt Rindsleder geprägt
104	Mod. 32	Montreal	Carbonlook auf echt Rindsleder geprägt
104	Mod. 31	Imola	Carbonlook auf echt Rindsleder geprägt

Seite	106 Vintage / Velours / Canvas		
107	Mod. 197	Liverpool	Echt Vintageleder
107	Mod. 196	Manchester	Echt Vintageleder
108	Mod. 195	Newcastle	Echt Vintageleder
108	Mod. 194	Chesterfield	Echt Vintageleder
109	Mod. 192	London	Echt Vintageleder
109	Mod. 190	Oxford	Echt Vintageleder
110	Mod. 188	Derby	Echt Vintageleder
110	Mod. 187	Indiana	Echt Canvas / Vintage
111	Mod. 186	Maryland	Echt Canvas / Vintage
111	Mod. 185	Ohio	Echt Canvas
112	Mod. 184	Virginia	Echt Canvas
112	Mod. 183	Georgia	Echt Vintageleder
113	Mod. 182	New Hampton	Echt Vintageleder
113	Mod. 180	Belfast	Echt Vintageleder
114	Mod. 179	Birmingham	Echt Vintageleder
114	Mod. 177	Winchester	Echt Vintageleder
115	Mod. 175	York	Echt Vintageleder
115	Mod. 173	Westminster	Echt Vintageleder
116	Mod. 172	Jersey	Echt Vintageleder
116	Mod. 169	Hawker	Echt Rindsleder »Camouflage«
117	Mod. 168	Douglas	Echt Rindsleder »Camouflage«
117	Mod. 167	Grand	Echt Rindsleder »Camouflage«
118	Mod. 165	Moore	Echt Rindsleder
118	Mod. 163	Baxter	Echt Rindsleder »Camouflage«
119	Mod. 161	Watts	Echt Rindsleder
119	Mod. 160	Sullivan	Echt Vintageleder
120	Mod. 159	Bedford	Echt Vintageleder
120	Mod. 158	Walker	Echt Vintageleder
121	Mod. 157	Harrison	Echt Vintageleder
121	Mod. 155	Hudson	Echt Velourleder
122	Mod. 152	Franklin	Echt Velourleder
122	Mod. 150	Tompson	Echt Velourleder

Page	Embossed Leather		
102	Mod. 37	Hollywood	Embossed Alligator Grain on Genuine Cow Leather
102	Mod. 36	Monza	Embossed Carbon Look Grain on Genuine Cow Leather
103	Mod. 35	Miami	Embossed Alligator Grain on Genuine Cow Leather
103	Mod. 33	Silverstone	Embossed Carbon Look Grain on Genuine Cow Leather
104	Mod. 32	Montreal	Embossed Carbon Look Grain on Genuine Cow Leather
104	Mod. 31	Imola	Embossed Carbon Look Grain on Genuine Cow Leather

Page	106 Vintage / Suede / Canvas		
107	Mod. 197	Liverpool	Genuine Vintage Leather
107	Mod. 196	Manchester	Genuine Vintage Leather
108	Mod. 195	Newcastle	Genuine Vintage Leather
108	Mod. 194	Chesterfield	Genuine Vintage Leather
109	Mod. 192	London	Genuine Vintage Leather
109	Mod. 190	Oxford	Genuine Vintage Leather
110	Mod. 188	Derby	Genuine Vintage Leather
110	Mod. 187	Indiana	Genuine Canvas / Vintage
111	Mod. 186	Maryland	Genuine Canvas / Vintage
111	Mod. 185	Ohio	Genuine Canvas
112	Mod. 184	Virginia	Genuine Canvas
112	Mod. 183	Georgia	Genuine Vintage Leather
113	Mod. 182	New Hampton	Genuine Vintage Leather
113	Mod. 180	Belfast	Genuine Vintage Leather
114	Mod. 179	Birmingham	Genuine Vintage Leather
114	Mod. 177	Winchester	Genuine Vintage Leather
115	Mod. 175	York	Genuine Vintage Leather
115	Mod. 173	Westminster	Genuine Vintage Leather
116	Mod. 172	Jersey	Genuine Vintage Leather
116	Mod. 169	Hawker	Genuine Cow Leather »Camouflage«
117	Mod. 168	Douglas	Genuine Cow Leather »Camouflage«
117	Mod. 167	Grand	Genuine Cow Leather »Camouflage«
118	Mod. 165	Moore	Genuine Cow Leather
118	Mod. 163	Baxter	Genuine Cow Leather »Camouflage«
119	Mod. 161	Watts	Genuine Cow Leather
119	Mod. 160	Sullivan	Genuine Vintage Leather
120	Mod. 159	Bedford	Genuine Vintage Leather
120	Mod. 158	Walker	Genuine Vintage Leather
121	Mod. 157	Harrison	Genuine Vintage Leather
121	Mod. 155	Hudson	Genuine Suede
122	Mod. 152	Franklin	Genuine Suede
122	Mod. 150	Tompson	Genuine Suede

Seite 124 Wasserfest

125	Mod. 149	Speed	Alligatorennarbung auf echt Rindsleder geprägt mit Kautschukgriff
125	Mod. 148	Power	Alligatorennarbung auf echt Rindsleder geprägt mit Kautschukgriff
126	Mod. 147	Polo	Echt Rindsleder mit Kautschukgriff
126	Mod. 146	Sunset	Echt Rindsleder mit Kautschukgriff
127	Mod. 144	Richmond	Silikon Faltschließe
127	Mod. 142	Kansas	Silikon
128	Mod. 140	Atlanta	Silikon
128	Mod. 134	Bass	Hightechmaterial Nytech
129	Mod. 133	Just	Hightechmaterial Nytech
129	Mod. 132	Advance	Hightechmaterial Nytech Futter mit Kautschukgriff
130	Mod. 131	Next	Hightechmaterial Ballistic
130	Mod. 130	Activity	Hightechmaterial Dynamic
131	Mod. 119	Dive	Echt Rindsleder (Hydrophobiert)
131	Mod. 118	Scuba	Echt Rindsleder (Hydrophobiert)
132	Mod. 117	Deep Sea	Echt Rindsleder (Hydrophobiert)
132	Mod. 116	Off Shore	Echt Rindsleder (Hydrophobiert)

Seite 134 Nato- / Durchzugsbänder

135	Mod. 498	Nato Bratislava	Echt Shell Cordovan Leder
135	Mod. 497	Nato Prague	Echt Shell Cordovan Leder
136	Mod. 496	Nato Budapest	Echt Shell Cordovan Leder
136	Mod. 495	Nato Sofia	Echt Canvas
137	Mod. 494	Nato Warsaw	Echt Canvas
137	Mod. 493	Nato Tallinn	Echt Canva
138	Mod. 491	Nato Amsterdam	Echt Vintageleder
138	Mod. 490	Nato Luxembourg	Echt Vintageleder
139	Mod. 489	Nato Riga	Echt Vintageleder
139	Mod. 488	Nato Brussels	Echt Vintageleder
140	Mod. 487	Nato Copenhagen	Echt Vintageleder
140	Mod. 486	Nato Oslo	Echt Vintageleder
141	Mod. 485	Nato Athens	Echt Kalbsleder
141	Mod. 484	Nato Lisbon	Echt Kalbsleder
142	Mod. 483	Nato Madrid	Echt Kalbsleder
142	Mod. 481	Nato Ottawa	Nylon
143	Mod. 480	Sailor	Geflochtenes Perlon

Page 124 Water resistant

125	Mod. 149	Speed	Embossed Alligator Grain on Genuine Cow Leather with rubber grip
125	Mod. 148	Power	Embossed Alligator Grain on Genuine Cow Leather with rubber grip
126	Mod. 147	Polo	Genuine Cow Leather with rubber grip
126	Mod. 146	Sunset	Genuine Cow Leather with rubber grip
127	Mod. 144	Richmond	Silicon Folding buckle
127	Mod. 142	Kansas	Silicon
128	Mod. 140	Atlanta	Silicon
128	Mod. 134	Bass	Hightech Material Nytech
129	Mod. 133	Just	Hightech Material Nytech
129	Mod. 132	Advance	Hightechmaterial Nytech Inner lining with rubber grip
130	Mod. 131	Next	Hightech Material Ballistic
130	Mod. 130	Activity	Hightech Material Dynamic
131	Mod. 119	Dive	Genuine Cow Leather (Hydrophobicity)
131	Mod. 118	Scuba	Genuine Cow Leather (Hydrophobicity)
132	Mod. 117	Deep Sea	Genuine Cow Leather (Hydrophobicity)
132	Mod. 116	Off Shore	Genuine Cow Leather (Hydrophobicity)

Page 134 Nato Straps / One-Piece Straps

135	Mod. 498	Nato Bratislava	Genuine Shell Cordovan Leather
135	Mod. 497	Nato Prague	Genuine Shell Cordovan Leather
136	Mod. 496	Nato Budapest	Genuine Shell Cordovan Leather
136	Mod. 495	Nato Sofia	Genuine Canvas
137	Mod. 494	Nato Warsaw	Genuine Canvas
137	Mod. 493	Nato Tallinn	Genuine Canvas
138	Mod. 491	Nato Amsterdam	Genuine Vintage Leather
138	Mod. 490	Nato Luxembourg	Genuine Vintage Leather
139	Mod. 489	Nato Riga	Genuine Vintage Leather
139	Mod. 488	Nato Brussels	Genuine Vintage Leather
140	Mod. 487	Nato Copenhagen	Genuine Vintage Leather
140	Mod. 486	Nato Oslo	Genuine Vintage Leather
141	Mod. 485	Nato Athens	Genuine Calfskin
141	Mod. 484	Nato Lisbon	Genuine Calfskin
142	Mod. 483	Nato Madrid	Genuine Calfskin
142	Mod. 481	Nato Ottawa	Nylon
143	Mod. 480	Sailor	Plaited Perlon

Seite 144 Ersatzbänder

Technische Angabe: RIOS1931-Band, insbesondere passend für Uhren der Marke »Apple (Smartwatch)«

151	Mod. 475	Messenger	Echt zertifiziertes Bioleder
151	Mod. 474	Online	Echt zertifiziertes Bioleder
152	Mod. 470	Stream	Alligatorennarbung auf echt Rindsleder geprägt
152	Mod. 464	Connect	Echt Büffelleder
153	Mod. 460	Life	Echt Vintageleder

Technische Angabe: RIOS1931 Band, insbesondere passend für Uhren der Marke »Omega«

154	Mod. 396	Master	Echt Alligatorenleder in matt, Fullcut
154	Mod. 390	Engineer	Echt Juchtenleder

Technische Angabe: RIOS1931 Band, insbesondere passend für Uhren der Marke »IWC«

155	Mod. 389	Thunderbird	Echt Alligatorenleder in matt, Fullcut
155	Mod. 388	Spitfire	Echt Alligatorenleder in matt, Fullcut
156	Mod. 386	Hurricane	Echt Alligatorenleder in matt, Fullcut
156	Mod. 385	Typhoon	Echt Büffelleder
157	Mod. 384	Blizzard	Echt Kalbsleder
157	Mod. 383	Scirocco	Echt Kalbsleder
158	Mod. 382	Albatros	Hightechmaterial Nytech

Technische Angabe: RIOS1931 Band, insbesondere passend für Uhren der Marke »Bell & Ross«

158	Mod. 380	Copter	Echt Juchtenleder
-----	----------	--------	-------------------

Technische Angabe: RIOS1931 Band, insbesondere passend für Uhren der Marke »Rolex Daytona«

159	Mod. 371	Prince	Echt Alligatorenleder in glanz, Fullcut
159	Mod. 370	King	Echt Alligatorenleder in matt, Fullcut

Technische Angabe: RIOS1931 Band, insbesondere passend für Uhren der Marke »Officine Panerai«

160	Mod. 364	Pisa	Echt Alligatorenleder in matt, Fullcut
160	Mod. 363	Modena	Echt Alligatorenleder in matt, Fullcut
161	Mod. 361	Milano	Echt Rindsleder (Hydrophobiert)
161	Mod. 360	Firenze	Echt Juchtenleder

Technische Angabe: RIOS1931 Band, insbesondere passend für Uhren der Marke »Cartier (Tank)«

162	Mod. 352	Louvre	Echt Alligatorenleder in matt, Fullcut
-----	----------	--------	--

Technische Angabe: RIOS1931 Band, insbesondere passend für Uhren der Marke »Cartier (Pasha)«

162	Mod. 350	Versailles	Echt Alligatorenleder in matt, Fullcut
-----	----------	------------	--

Alle aufgeführten Firmen, Marken und Kennzeichen sind Eigentum der jeweiligen Hersteller, bzw. Markeninhaber und dienen lediglich der Beschreibung.

Page 144 Replacement Straps

Technical specification: RIOS1931 watch strap, particularly suitable for watches of the brand »Apple (Smart watches)«

151	Mod. 475	Messenger	Genuine Certified Organic Leather
151	Mod. 474	Online	Genuine Certified Organic Leather
152	Mod. 470	Stream	Embossed Alligator Grain on Genuine Cow Leather
152	Mod. 464	Connect	Genuine Buffalo Leather
153	Mod. 460	Life	Genuine Vintage Leather

Technical specification: RIOS1931 watch strap, particularly suitable for watches of the brand »Omega«

154	Mod. 396	Master	Genuine Alligator Leather, matt finish, fullcut
154	Mod. 390	Engineer	Genuine Russia Leather

Technical specification: RIOS1931 watch strap, particularly suitable for watches of the brand »IWC«

155	Mod. 389	Thunderbird	Genuine Alligator Leather, matt finish, fullcut
155	Mod. 388	Spitfire	Genuine Alligator Leather, matt finish, fullcut
156	Mod. 386	Hurricane	Genuine Alligator Leather, matt finish, fullcut
156	Mod. 385	Typhoon	Genuine Buffalo Leather
157	Mod. 384	Blizzard	Genuine Calfskin
157	Mod. 383	Scirocco	Genuine Calfskin
158	Mod. 382	Albatros	Hightech Material Nytech

Technical specification: RIOS1931 watch strap, particularly suitable for watches of the brand »Bell & Ross«

158	Mod. 380	Copter	Genuine Russia Leather
-----	----------	--------	------------------------

Technical specification: RIOS1931 watch strap, particularly suitable for watches of the brand »Rolex Daytona«

159	Mod. 371	Prince	Genuine Alligator Leather, glossy finish, fullcut
159	Mod. 370	King	Genuine Alligator Leather, matt finish, fullcut

Technical specification: RIOS1931 watch strap, particularly suitable for watches of the brand »Officine Panerai«

160	Mod. 364	Pisa	Genuine Alligator Leather, matt finish, fullcut
160	Mod. 363	Modena	Genuine Alligator Leather, matt finish, fullcut
161	Mod. 361	Milano	Genuine Cow Leather (Hydrophobicity)
161	Mod. 360	Firenze	Genuine Russia Leather

Technical specification: RIOS1931 watch strap, particularly suitable for watches of the brand »Cartier (Tank)«

162	Mod. 352	Louvre	Genuine Alligator Leather, matt finish, fullcut
-----	----------	--------	---

Technical specification: RIOS1931 watch strap, particularly suitable for watches of the brand »Cartier (Pasha)«

162	Mod. 350	Versailles	Genuine Alligator Leather, matt finish, fullcut
-----	----------	------------	---

All the listed companies, brands and symbols are the property of the respective manufacturer and/or brand owners and are for the descriptive purposes only.

Technische Angabe: RIOS1931 Band, insbesondere passend für Uhren der Marke »Patek Philippe«

163	Mod.345	Basel	Echt Alligatorenleder in glanz, Fullcut
163	Mod.344	Zürich	Echt Alligatorenleder in matt, Fullcut
164	Mod.341	Lausanne	Echt Alligatorenleder in glanz, Fullcut
164	Mod.340	Geneve	Echt Alligatorenleder in matt, Fullcut

Technische Angabe: RIOS1931-Band, insbesondere passend für Uhren der Marke »Jäger le Coultre«

165	Mod.333	Avandgarde	Echt Alligatorenleder in matt, Fullcut
165	Mod.332	Legend	Echt Alligatorenleder in matt, Fullcut
166	Mod.330	Maxime	Echt Straußenleder

Technische Angabe: RIOS1931 Band, insbesondere passend für Uhren der Marke »TAG Heuer«

166	Mod.322	Projeter	Echt Alligatorenleder in matt, Fullcut
167	Mod.320	Vision	Echt Juchtenleder

Technische Angabe: RIOS1931 Band, insbesondere passend für Uhren der Marke »Breitling«

167	Mod.316	Jet	Echt Alligatorenleder in matt, Fullcut
168	Mod.315	Aero	Echt Alligatorenleder in matt, Fullcut
168	Mod.312	Tornado	Echt Juchtenleder
169	Mod.311	Pilot	Echt Juchtenleder
169	Mod.310	Continental	Echt Haifischleder

Alle aufgeführten Firmen, Marken und Kennzeichen sind Eigentum der jeweiligen Hersteller, bzw. Markeninhaber und dienen lediglich der Beschreibung.

171	Mod.599	Juri	Echt Alligatorenleder in matt, Flank
171	Mod.598	Maxim	Echt Alligatorenleder in matt, Flank
172	Mod.597	Iwan	Echt Vintageleder
173	Mod.596	Alexander	Alligatorennarbung auf echt Rindsleder geprägt
173	Mod.595	Artur	Echt Büffelleleder
175	Mod.589	Georg	Echt Alligatorenleder in matt, Fullcut
175	Mod.588	Robert	Echt Alligatorenleder in matt, Flank
175	Mod.587	David	Echt Shell Cordovan
175	Mod.586	Adam	Echt Vintageleder
176	Mod.579	Carlo	Echt Vintageleder
176	Mod.569	Julius	Echt Vintageleder
177	Mod.559	Constantin	Echt Vintageleder
177	Mod.549	Leonardo	Echt Lamleder

Technical specification: RIOS1931 watch strap, particularly suitable for watches of the brand »Patek Philippe«

163	Mod.345	Basel	Genuine Alligator Leather, glossy finish, fullcut
163	Mod.344	Zürich	Genuine Alligator Leather, matt finish, fullcut
164	Mod.341	Lausanne	Genuine Alligator Leather, glossy finish, fullcut
164	Mod.340	Geneve	Genuine Alligator Leather, matt finish, fullcut

Technical specification: RIOS1931 watch strap, particularly suitable for watches of the brand »Jäger le Coultre«

165	Mod.333	Avandgarde	Genuine Alligator Leather, matt finish, fullcut
165	Mod.332	Legend	Genuine Alligator Leather, matt finish, fullcut
166	Mod.330	Maxime	Genuine Ostrich Leather

Technical specification: RIOS1931 watch strap, particularly suitable for watches of the brand »TAG Heuer«

166	Mod.322	Projeter	Genuine Alligator Leather, matt finish, fullcut
167	Mod.320	Vision	Genuine Russia Leather

Technical specification: RIOS1931 watch strap, particularly suitable for watches of the brand »Breitling«

167	Mod.316	Jet	Genuine Alligator Leather, matt finish, fullcut
168	Mod.315	Aero	Genuine Alligator Leather, matt finish, fullcut
168	Mod.312	Tornado	Genuine Russia Leather
169	Mod.311	Pilot	Genuine Russia Leather
169	Mod.310	Continental	Genuine Shark Leather

All the listed companies, brands and symbols are the property of the respective manufacturer and / or brand owners and are for the descriptive purposes only.

171	Mod.599	Juri	Genuine Alligator Leather, matt finish, flank
171	Mod.598	Maxim	Genuine Alligator Leather, matt finish, flank
172	Mod.597	Iwan	Genuine Vintage Leather
173	Mod.596	Alexander	Embossed Alligator Grain on Genuine Cow Leather
173	Mod.595	Artur	Genuine Buffalo Leather
175	Mod.589	Georg	Genuine Alligator Leather, matt finish, fullcut
175	Mod.588	Robert	Genuine Alligator Leather, matt finish, flank
175	Mod.587	David	Genuine Shell Cordovan Leather
175	Mod.586	Adam	Genuine Vintage Leather
176	Mod.579	Carlo	Genuine Vintage Leather
176	Mod.569	Julius	Genuine Vintage Leather
177	Mod.559	Constantin	Genuine Vintage Leather
177	Mod.549	Leonardo	Genuine Lambskin

Mod.		Leder / Material	Seite
20	Ecco	Echt Rindsleder	85
21	Racing	Echt Rindsleder mit Racinglöchern	84
30S	Diplomat »mit Spange«	Echt Rindsleder	84
31	Imola	Carbonlook auf echt Rindsleder geprägt	104
32	Montreal	Carbonlook auf echt Rindsleder geprägt	104
33	Silverstone	Carbonlook auf echt Rindsleder geprägt	103
34	Classic	Echt Rindsleder	83
35	Miami	Alligatorennarbung auf echt Rindsleder geprägt	103
36	Monza	Carbonlook auf echt Rindsleder	102
37	Hollywood	Alligatorennarbung auf echt Rindsleder geprägt	102
38	Tobacco	Echt Schweinsleder	92
39	Havana	Echt Schweinsleder	91
41	Solid	Echt Rindsleder	83
42	Bolivia	Teju-Eidechsenarbung auf echt Rindsleder geprägt	101
43	Elegant	Echt Rindsleder	82
44	Smart	Echt Rindsleder	82
45	French	Echt Rindsleder	81
46	Arizona	Echt Sattelleder	80
46S	Arizona »mit Spange«	Echt Sattelleder	81
47	Merino	Echt Lammlleder	91
48	Durban	Straußennarbung auf echt Rindsleder geprägt	101
49	Argentina	Alligatorennarbung auf echt Rindsleder geprägt	100
49S	Argentina »mit Spange«	Alligatorennarbung auf echt Rindsleder geprägt	100
50	Louisiana	Alligatorennarbung auf echt Rindsleder geprägt	99
51	New Orleans	Alligatorennarbung auf echt Rindsleder geprägt	99
52	Orlando	Alligatorennarbung auf echt Rindsleder geprägt	98
53	Panama	Alligatorennarbung auf echt Rindsleder geprägt	98
54	California Sport	Echt Sattelleder	80
55	Cashmere	Echt Lammlleder	90
56	Dallas	Alligatorennarbung auf echt Rindsleder geprägt	97
57	Boston	Alligatorennarbung auf echt Rindsleder geprägt	97
58	Baltimore	Alligatorennarbung auf echt Rindsleder geprägt	96
59	Vegas	Alligatorennarbung auf echt Rindsleder geprägt	96
60	Ocean	Haifischnarbung auf echt Rindsleder geprägt	95
61	Nature	Echt Büffelleder	89

Mod.		Leather / material	Page
20	Ecco	Genuine Cowhide	85
21	Racing	Genuine Cowhide with racing holes	84
30S	Diplomat »with clasp«	Genuine Cowhide	84
31	Imola	Embossed Carbon Look Grain on Genuine Cow Leather	104
32	Montreal	Embossed Carbon Look Grain on Genuine Cow Leather	104
33	Silverstone	Embossed Carbon Look Grain on Genuine Cow Leather	103
34	Classic	Genuine Cowhide	83
35	Miami	Embossed Alligator Grain on Genuine Cow Leather	103
36	Monza	Embossed Carbon Look Grain on Genuine Cow Leather	102
37	Hollywood	Embossed Alligator Grain on Genuine Cow Leather	102
38	Tobacco	Genuine Pigskin	92
39	Havana	Genuine Pigskin	91
41	Solid	Genuine Cowhide	83
42	Bolivia	Embossed Teju Lizard Grain on Genuine Cow Leather	101
43	Elegant	Genuine Cowhide	82
44	Smart	Genuine Cowhide	82
45	French	Genuine Cowhide	81
46	Arizona	Genuine Saddle Leather	80
46S	Arizona »with clasp«	Genuine Saddle Leather	81
47	Merino	Genuine Lambskin	91
48	Durban	Embossed Ostrich Grain on Genuine Cow Leather	101
49	Argentina	Embossed Alligator Grain on Genuine Cow Leather	100
49S	Argentina »with clasp«	Embossed Alligator Grain on Genuine Cow Leather	100
50	Louisiana	Embossed Alligator Grain on Genuine Cow Leather	99
51	New Orleans	Embossed Alligator Grain on Genuine Cow Leather	99
52	Orlando	Embossed Alligator Grain on Genuine Cow Leather	98
53	Panama	Embossed Alligator Grain on Genuine Cow Leather	98
54	California Sport	Genuine Saddle Leather	80
55	Cashmere	Genuine Lambskin	90
56	Dallas	Embossed Alligator Grain on Genuine Cow Leather	97
57	Boston	Embossed Alligator Grain on Genuine Cow Leather	97
58	Baltimore	Embossed Alligator Grain on Genuine Cow Leather	96
59	Vegas	Embossed Alligator Grain on Genuine Cow Leather	96
60	Ocean	Embossed Shark Grain on Genuine Cow Leather	95
61	Nature	Genuine Buffalo Leather	89

Mod.	Leder / Material	Seite	
62	Texas	Echt Büffelleder	90
64	Colorado	Echt Büffelleder	89
65	Montana	Echt Büffelleder	88
68	Nevada	Echt Sattelleder	79
70	Brazil	Krokodilnarbung auf echt Rindsleder geprägt	95
102	Toscana	Echt Kalbsleder	79
104	Capri	Echt Kalbsleder	78
116	Off Shore	Echt Rindsleder (Hydrophobiert)	132
117	Deep Sea	Echt Rindsleder (Hydrophobiert)	132
118	Scuba	Echt Rindsleder (Hydrophobiert)	131
119	Dive	Echt Rindsleder (Hydrophobiert)	131
130	Activity	Hightechmaterial Dynamic	130
131	Next	Hightechmaterial Balistic	130
132	Advance	Hightechmaterial Nytech	129
133	Just	Hightechmaterial Nytech	129
134	Bass	Hightechmaterial Nytech	128
135	Maranello	Echt Kalbsleder	78
137	Veneto	Echt Kalbsleder	77
138	Apulia	Echt Kalbsleder	77
140	Atlanta	Silikon	128
142	Kansas	Silikon	127
144	Richmond	Silikon Faltschließe	127
146	Sunset	Echt Rindsleder mit Kautschukgriff	126
147	Polo	Echt Rindsleder mit Kautschukgriff	126
148	Power	Alligatorennarbung auf echt Rindsleder geprägt	125
149	Speed	Alligatorennarbung auf echt Rindsleder geprägt	125
150	Tompson	Echt Velourleder	122
152	Franklin	Echt Velourleder	122
155	Hudson	Echt Velourleder	121
157	Harrison	Echt Vintageleder	121
158	Walker	Echt Vintageleder	120
159	Bedford	Echt Vintageleder	120
160	Sullivan	Echt Vintageleder	119
161	Watts	Echt Rindsleder	119
163	Baxter	Echt Rindsleder »Camouflage«	118

Mod.	Leather / material	Page	
62	Texas	Genuine Buffalo Leather	90
64	Colorado	Genuine Buffalo Leather	89
65	Montana	Genuine Buffalo Leather	88
68	Nevada	Genuine Saddle Leather	79
70	Brazil	Embossed Crocodile Grain on Genuine Cow Leather	95
102	Toscana	Genuine Calfskin	79
104	Capri	Genuine Calfskin	78
116	Off Shore	Genuine Cow Leather (Hydrophobicity)	132
117	Deep Sea	Genuine Cow Leather (Hydrophobicity)	132
118	Scuba	Genuine Cow Leather (Hydrophobicity)	131
119	Dive	Genuine Cow Leather (Hydrophobicity)	131
130	Activity	Hightech Material Dynamic	130
131	Next	Hightech Material Balistic	130
132	Advance	Hightechmaterial Nytech	129
133	Just	Hightech Material Nytech	129
134	Bass	Hightech Material Nytech	128
135	Maranello	Genuine Calfskin	78
137	Veneto	Genuine Calfskin	77
138	Apulia	Genuine Calfskin	77
140	Atlanta	Silicon	128
142	Kansas	Silicon	127
144	Richmond	Silicon Folding buckle	127
146	Sunset	Genuine Cow Leather with rubber grip	126
147	Polo	Genuine Cow Leather with rubber grip	126
148	Power	Embossed Alligator Grain on Genuine Cow Leather	125
149	Speed	Embossed Alligator Grain on Genuine Cow Leather	125
150	Tompson	Genuine Suede	122
152	Franklin	Genuine Suede	122
155	Hudson	Genuine Suede	121
157	Harrison	Genuine Vintage Leather	121
158	Walker	Genuine Vintage Leather	120
159	Bedford	Genuine Vintage Leather	120
160	Sullivan	Genuine Vintage Leather	119
161	Watts	Genuine Cow Leather	119
163	Baxter	Genuine Cow Leather »Camouflage«	118

Mod.	Leder / Material	Seite	
165	Moore	Echt Rindsleder	118
167	Grand	Echt Rindsleder »Camouflage«	117
168	Douglas	Echt Rindsleder »Camouflage«	117
169	Hawker	Echt Rindsleder »Camouflage«	116
172	Jersey	Echt Vintageleder	116
173	Westminster	Echt Vintageleder	115
175	York	Echt Vintageleder	115
177	Winchester	Echt Vintageleder	114
179	Birmingham	Echt Vintageleder	114
180	Belfast	Echt Vintageleder	113
182	New Hampton	Echt Vintageleder	113
183	Georgia	Echt Vintageleder	112
184	Virginia	Echt Canvas	112
185	Ohio	Echt Canvas	111
186	Maryland	Echt Canvas / Vintage	111
187	Indiana	Echt Canvas / Vintage	110
188	Derby	Echt Vintageleder	110
190	Oxford	Echt Vintageleder	109
192	London	Echt Vintageleder	109
193	Seattle	Echt Shell Cordovan Leder	75
194	Chesterfield	Echt Vintageleder	108
195	Newcastle	Echt Vintageleder	108
196	Manchester	Echt Vintageleder	107
197	Liverpool	Echt Vintageleder	107
198	Chicago	Echt Shell Cordovan Leder	74
199	New York	Echt Shell Cordovan Leder	74
200	Moscow	Echt Juchtenleder	73
201	St. Petersburg	Echt Juchtenleder	73
202	Samara	Echt Juchtenleder	72
203	Pensa	Echt Juchtenleder	72
204	Tula	Echt Juchtenleder mit Uhren-Lederunterlage	71
205	Kaluga	Echt Juchtenleder	71
206	Advantage	Echt Büffelleder	88
207	Performance	Echt Büffelleder	87
209	Aviator	Echt Büffelleder	87

Mod.	Leather / material	Page	
165	Moore	Genuine Cow Leather	118
167	Grand	Genuine Cow Leather »Camouflage«	117
168	Douglas	Genuine Cow Leather »Camouflage«	117
169	Hawker	Genuine Cow Leather »Camouflage«	116
172	Jersey	Genuine Vintage Leather	116
173	Westminster	Genuine Vintage Leather	115
175	York	Genuine Vintage Leather	115
177	Winchester	Genuine Vintage Leather	114
179	Birmingham	Genuine Vintage Leather	114
180	Belfast	Genuine Vintage Leather	113
182	New Hampton	Genuine Vintage Leather	113
183	Georgia	Genuine Vintage Leather	112
184	Virginia	Genuine Canvas	112
185	Ohio	Genuine Canvas	111
186	Maryland	Genuine Canvas / Vintage	111
187	Indiana	Genuine Canvas / Vintage	110
188	Derby	Genuine Vintage Leather	110
190	Oxford	Genuine Vintage Leather	109
192	London	Genuine Vintage Leather	109
193	Seattle	Genuine Shell Cordovan Leather	75
194	Chesterfield	Genuine Vintage Leather	108
195	Newcastle	Genuine Vintage Leather	108
196	Manchester	Genuine Vintage Leather	107
197	Liverpool	Genuine Vintage Leather	107
198	Chicago	Genuine Shell Cordovan Leather	74
199	New York	Genuine Shell Cordovan Leather	74
200	Moscow	Genuine Russia Leather	73
201	St. Petersburg	Genuine Russia Leather	73
202	Samara	Genuine Russia Leather	72
203	Pensa	Genuine Russia Leather	72
204	Tula	Genuine Russia Leather with watch leather underlay	71
205	Kaluga	Genuine Russia Leather	71
206	Advantage	Genuine Buffalo Leather	88
207	Performance	Genuine Buffalo Leather	87
209	Aviator	Genuine Buffalo Leather	87

Mod.	Leder / Material	Seite	
210	Wave	Echt Haifischleder	56
218	Charme	Echt Eidechsenleder in glanz	56
220	Allure	Echt Eidechsenleder in glanz	55
222	Avenue	Echt Teju-Eidechsenleder in glanz	55
230	Maison	Echt Strau�enleder	54
240	Lord	Echt Krokodilleder in glanz	54
241	Royal	Echt Alligatorenleder in matt, Flank	53
244	Prestige	Echt Alligatorenleder in matt, Flank	53
245	Brilliant	Echt Alligatorenleder in glanz, Flank	52
248	Imperial	Echt Alligatorenleder in matt, Flank	52
249	Heritage	Echt Alligatorenleder in glanz, Flank	51
250	Ambassador	Echt Alligatorenleder in matt, Flank	51
252	Superior	Echt Alligatorenleder in matt, Flank	50
256	Connoisseur	Echt Alligatorenleder in matt, Fullcut	50
266	Monarch	Echt Alligatorenleder in matt, Fullcut	49
270	Imperator	Echt Alligatorenleder in matt, Fullcut	49
272	Senator	Echt Alligatorenleder in matt, Fullcut	48
273	Premier	Echt Alligatorenleder in glanz, Fullcut	48
276	President	Echt Alligatorenleder in matt, Fullcut	47
277	Windsor	Echt Alligatorenleder in glanz, Fullcut	47
310	Continental	Echt Haifischleder	169
311	Pilot	Echt Juchtenleder	169
312	Tornado	Echt Juchtenleder	168
315	Aero	Echt Alligatorenleder in mat, Fullcut	168
316	Jet	Echt Alligatorenleder in matt, Fullcut	167
320	Vision	Echt Juchtenleder	167
322	Projeter	Echt Alligatorenleder in matt, Fullcut	166
330	Maxime	Echt Strau�enleder	166
332	Legend	Echt Alligatorenleder in matt, Fullcut	165
333	Avandgarde	Echt Alligatorenleder in matt, Fullcut	165
340	Geneve	Echt Alligatorenleder in matt, Fullcut	164
341	Lausanne	Echt Alligatorenleder in glanz, Fullcut	164
344	Z�rich	Echt Alligatorenleder in matt, Fullcut	163
345	Basel	Echt Alligatorenleder in glanz, Fullcut	163
350	Versailles	Echt Alligatorenleder in matt, Fullcut	162

Mod.	Leather / material	Page	
210	Wave	Genuine Shark Leather	56
218	Charme	Genuine Lizard Leather, glossy finish	56
220	Allure	Genuine Lizard Leather, glossy finish	55
222	Avenue	Genuine Teju Lizard Leather, glossy finish	55
230	Maison	Genuine Ostrich Leather	54
240	Lord	Genuine Crocodile Leather, glossy finish	54
241	Royal	Genuine Alligator Leather, matt finish, flank	53
244	Prestige	Genuine Alligator Leather, matt finish, flank	53
245	Brilliant	Genuine Alligator Leather, glossy finish, flank	52
248	Imperial	Genuine Alligator Leather, matt finish, flank	52
249	Heritage	Genuine Alligator Leather, glossy finish, flank	51
250	Ambassador	Genuine Alligator Leather, matt finish, flank	51
252	Superior	Genuine Alligator Leather, matt finish, flank	50
256	Connoisseur	Genuine Alligator Leather, matt finish, fullcut	50
266	Monarch	Genuine Alligator Leather, matt finish, fullcut	49
270	Imperator	Genuine Alligator Leather, matt finish, fullcut	49
272	Senator	Genuine Alligator Leather, matt finish, fullcut	48
273	Premier	Genuine Alligator Leather, glossy finish, fullcut	48
276	President	Genuine Alligator Leather, matt finish, fullcut	47
277	Windsor	Genuine Alligator Leather, glossy finish, fullcut	47
310	Continental	Genuine Shark Leather	169
311	Pilot	Genuine Russia Leather	169
312	Tornado	Genuine Russia Leather	168
315	Aero	Genuine Alligator Leather, matt finish, fullcut	168
316	Jet	Genuine Alligator Leather, matt finish, fullcut	167
320	Vision	Genuine Russia Leather	167
322	Projeter	Genuine Alligator Leather, matt finish, fullcut	166
330	Maxime	Genuine Ostrich Leather	166
332	Legend	Genuine Alligator Leather, matt finish, fullcut	165
333	Avandgarde	Genuine Alligator Leather, matt finish, fullcut	165
340	Geneve	Genuine Alligator Leather, matt finish, fullcut	164
341	Lausanne	Genuine Alligator Leather, glossy finish, fullcut	164
344	Z�rich	Genuine Alligator Leather, matt finish, fullcut	163
345	Basel	Genuine Alligator Leather, glossy finish, fullcut	163
350	Versailles	Genuine Alligator Leather, matt finish, fullcut	162

Mod.	Leder / Material	Seite	
352	Louvre	Echt Alligatorenleder in matt, Fullcut	162
360	Firenze	Echt Juchtenleder	161
361	Milano	Echt Rindsleder (Hydrophobiert)	161
363	Modena	Echt Alligatorenleder in matt, Fullcut	160
364	Pisa	Echt Alligatorenleder in matt, Fullcut	160
370	King	Echt Alligatorenleder in matt, Fullcut	159
371	Prince	Echt Alligatorenleder in glanz, Fullcut	159
380	Copter	Echt Juchtenleder	158
382	Albatros	Hightechmaterial Nytech	158
383	Scirocco	Echt Kalbsleder	157
384	Blizzard	Echt Kalbsleder	157
385	Typhoon	Echt Büffelleder	156
386	Hurricane	Echt Alligatorenleder in matt, Fullcut	156
388	Spitfire	Echt Alligatorenleder in matt, Fullcut	155
389	Thunderbird	Echt Alligatorenleder in matt, Fullcut	155
390	Engineer	Echt Juchtenleder	154
396	Master	Echt Alligatorenleder in matt, Fullcut	154
400	Kempton	Echt zertifiziertes Bioleder	69
404	Mittenwald	Echt zertifiziertes Bioleder	68
405	Inzell	Echt zertifiziertes Bioleder	68
408	Waging	Echt zertifiziertes Bioleder	67
412	Peiting	Echt zertifiziertes Bioleder	67
416	Füssen	Echt zertifiziertes Bioleder	66
420	Schongau	Echt zertifiziertes Bioleder	66
423	Landsberg	Echt zertifiziertes Bioleder	65
427	Sonthofen	Echt zertifiziertes Bioleder	65
428	Garmisch	Echt zertifiziertes Bioleder	64
429	Weilheim	Echt zertifiziertes Bioleder	64
432	Tegernsee	Echt zertifiziertes Bioleder	63
433	Starnberg	Echt zertifiziertes Bioleder	63
460	Life	Echt Vintageleder	153
464	Connect	Echt Büffelleder	152
470	Stream	Alligatorennarbung auf echt Rindsleder geprägt	152
474	Online	Echt zertifiziertes Bioleder	151
475	Messenger	Echt zertifiziertes Bioleder	151

Mod.	Leather / material	Page	
352	Louvre	Genuine Alligator Leather, matt finish, fullcut	162
360	Firenze	Genuine Russia Leather	161
361	Milano	Genuine Cow Leather (Hydrophobicity)	161
363	Modena	Genuine Alligator Leather, matt finish, fullcut	160
364	Pisa	Genuine Alligator Leather, matt finish, fullcut	160
370	King	Genuine Alligator Leather, matt finish, fullcut	159
371	Prince	Genuine Alligator Leather, glossy finish, fullcut	159
380	Copter	Genuine Russia Leather	158
382	Albatros	Hightech Material Nytech	158
383	Scirocco	Genuine Calfskin	157
384	Blizzard	Genuine Calfskin	157
385	Typhoon	Genuine Buffalo Leather	156
386	Hurricane	Genuine Alligator Leather, matt finish, fullcut	156
388	Spitfire	Genuine Alligator Leather, matt finish, fullcut	155
389	Thunderbird	Genuine Alligator Leather, matt finish, fullcut	155
390	Engineer	Genuine Russia Leather	154
396	Master	Genuine Alligator Leather, matt finish, fullcut	154
400	Kempton	Genuine Certified Organic Leather	69
404	Mittenwald	Genuine Certified Organic Leather	68
405	Inzell	Genuine Certified Organic Leather	68
408	Waging	Genuine Certified Organic Leather	67
412	Peiting	Genuine Certified Organic Leather	67
416	Füssen	Genuine Certified Organic Leather	66
420	Schongau	Genuine Certified Organic Leather	66
423	Landsberg	Genuine Certified Organic Leather	65
427	Sonthofen	Genuine Certified Organic Leather	65
428	Garmisch	Genuine Certified Organic Leather	64
429	Weilheim	Genuine Certified Organic Leather	64
432	Tegernsee	Genuine Certified Organic Leather	63
433	Starnberg	Genuine Certified Organic Leather	63
460	Life	Genuine Vintage Leather	153
464	Connect	Genuine Buffalo Leather	152
470	Stream	Embossed Alligator Grain on Genuine Cow Leather	152
474	Online	Genuine Certified Organic Leather	151
475	Messenger	Genuine Certified Organic Leather	151

Mod.	Leder / Material	Seite
480	Sailor <i>Geflochtenes Perlon</i>	143
481	Nato Ottawa <i>Nylon</i>	142
483	Nato Madrid <i>Echt Kalbsleder</i>	142
484	Nato Lisbon <i>Echt Kalbsleder</i>	141
485	Nato Athens <i>Echt Kalbsleder</i>	141
486	Nato Oslo <i>Echt Vintageleder</i>	140
487	Nato Copenhagen <i>Echt Vintageleder</i>	140
488	Nato Brussels <i>Echt Vintageleder</i>	139
489	Nato Riga <i>Echt Vintageleder</i>	139
490	Nato Luxembourg <i>Echt Vintageleder</i>	138
491	Nato Amsterdam <i>Echt Vintageleder</i>	138
493	Nato Tallinn <i>Echt Canva</i>	137
494	Nato Warsaw <i>Echt Canvas</i>	137
495	Nato Sofia <i>Echt Canvas</i>	136
496	Nato Budapest <i>Echt Shell Cordovan Leder</i>	136
497	Nato Prague <i>Echt Shell Cordovan Leder</i>	135
498	Nato Bratislava <i>Echt Shell Cordovan Leder</i>	135
549	Leonardo <i>Echt Lammlleder</i>	177
559	Constantin <i>Echt Vintageleder</i>	177
569	Julius <i>Echt Vintageleder</i>	176
579	Carlo <i>Echt Vintageleder</i>	176
586	Adam <i>Echt Vintageleder</i>	175
587	David <i>Echt Shell Cordovan</i>	175
588	Robert <i>Echt Alligatorenleder in matt, Flank</i>	175
589	Georg <i>Echt Alligatorenleder in matt, Fullcut</i>	175
595	Artur <i>Echt Büffelleder</i>	173
596	Alexander <i>Alligatorennarbung auf echt Rindsleder geprägt</i>	173
597	Iwan <i>Echt Vintageleder</i>	172
598	Maxim <i>Echt Alligatorenleder in matt, Flank</i>	171
599	Juri <i>Echt Alligatorenleder in matt, Flank</i>	171

Mod.	Leather / material	Page
480	Sailor <i>Plaited Perlon</i>	143
481	Nato Ottawa <i>Nylon</i>	142
483	Nato Madrid <i>Genuine Calfskin</i>	142
484	Nato Lisbon <i>Genuine Calfskin</i>	141
485	Nato Athens <i>Genuine Calfskin</i>	141
486	Nato Oslo <i>Genuine Vintage Leather</i>	140
487	Nato Copenhagen <i>Genuine Vintage Leather</i>	140
488	Nato Brussels <i>Genuine Vintage Leather</i>	139
489	Nato Riga <i>Genuine Vintage Leather</i>	139
490	Nato Luxembourg <i>Genuine Vintage Leather</i>	138
491	Nato Amsterdam <i>Genuine Vintage Leather</i>	138
493	Nato Tallinn <i>Genuine Canvas</i>	137
494	Nato Warsaw <i>Genuine Canvas</i>	137
495	Nato Sofia <i>Genuine Canvas</i>	136
496	Nato Budapest <i>Genuine Shell Cordovan Leather</i>	136
497	Nato Prague <i>Genuine Shell Cordovan Leather</i>	135
498	Nato Bratislava <i>Genuine Shell Cordovan Leather</i>	135
549	Leonardo <i>Genuine Lambskin</i>	177
559	Constantin <i>Genuine Vintage Leather</i>	177
569	Julius <i>Genuine Vintage Leather</i>	176
579	Carlo <i>Genuine Vintage Leather</i>	176
586	Adam <i>Genuine Vintage Leather</i>	175
587	David <i>Genuine Shell Cordovan Leather</i>	175
588	Robert <i>Genuine Alligator Leather, matt finish, flank</i>	175
589	Georg <i>Genuine Alligator Leather, matt finish, fullcut</i>	175
595	Artur <i>Genuine Buffalo Leather</i>	173
596	Alexander <i>Embossed Alligator Grain on Genuine Cow Leather</i>	173
597	Iwan <i>Genuine Vintage Leather</i>	172
598	Maxim <i>Genuine Alligator Leather, matt finish, flank</i>	171
599	Juri <i>Genuine Alligator Leather, matt finish, flank</i>	171

Seit 1931

Since 1931



*Firmengründer Oswald Riemer mit Täschnermeister
Company founder Oswald Riemer with a master leather craftsman*



*Gruppenbild Belegschaft von 1938
Group picture of the staff of 1938*



*Blick in die Manufaktur von 1938
A look into the workshop of 1938*

Der Tradition verbunden, dem Zeitgeist verpflichtet.

*Steeped in tradition,
inspired by the zeitgeist.*

Mit einem Uhrarmband von RIOS1931 erwerben Sie ein absolut hochwertiges Handwerksprodukt. Seit unserer Firmengründung durch den Uhrmachermeister Oswald Riemer 1931 stellen wir Uhrenarmbänder nach dem traditionellen Schweizer Vollumbugverfahren her. Damals wie heute eine Methode, um höchsten Qualitätsansprüchen voll und ganz gerecht zu werden.

Als Familienunternehmen in der dritten Generation stehen wir noch immer hinter der Firmenphilosophie, die Oswald Riemer einst formulierte: »Das handwerkliche Können bewahren und die technischen sowie modischen Anforderungen der Zeit erfüllen.« Die Kombination aus traditioneller, handwerklicher Perfektion und ständiger Weiterentwicklung macht die Uhrenarmbänder von RIOS1931 weltweit einzigartig.

When you purchase a RIOS1931 watch strap you are acquiring a high quality craft product. Since the foundation of our company by watchmaker Oswald Riemer in 1931, we have always used the Swiss full-bugg technique. Then as now, this is a method designed to ensure the highest level of quality.

As a family business in its third generation, we still have the same philosophy as originally defined by Oswald Riemer: »Preserve skilled craftsmanship while focusing on fashion and meeting the technical requirements of the day.« The combination of traditional, handcrafted perfection while constantly evolving has made the watch straps of RIOS1931 a unique product worldwide.



| Guido Satzger |

| Andreas Riemer |

Andreas Riemer (rechts) Geschäftsführer und Namensträger in der dritten Generation und Guido Satzger (links) Geschäftsführer anlässlich der Verleihung der Urkunde im Namen der Stadt Augsburg für »Qualität - Made in Augsburg« durch den Oberbürgermeister Dr. Kurt Gribl, am 26. Juni 2017 im Goldenen Saal der Stadt Augsburg.

Andreas Riemer (right), President and third-generation member of the family which gave the company its name, and Guido Satzger (left), CEO, are marking the presentation of the certificate awarded by the City of Augsburg for »Quality – made in Augsburg« by the Lord Mayor Dr. Kurt Gribl on the 26th June 2017 in the Golden Hall in the City of Augsburg.



Made in Germany

Die Garantie für die gleichbleibend hohe Qualität unserer Uhrenarmbänder ist der Firmenstandort Deutschland.

In unserer Manufaktur bilden wir unsere Mitarbeiter noch selbst aus. Während der jahrelangen Einarbeitungsphase erwerben sie die hohe Fachkompetenz, die zur Herstellung eines RIOS1931-Uhrarmbandes nötig ist.

Mit geschultem Auge und größter Sorgfalt wählen wir die zur Herstellung unserer Armbänder benötigten Materialien aus. Wir verwenden ausschließlich einwandfreies, bestes Leder. Durch die fachkundige sowie exakte Verarbeitung können Sie bei RIOS1931 sicher sein, absolut zuverlässige und langlebige Luxusprodukte allerhöchster Güte zu erhalten.

The guarantee for the consistently high quality of our watch straps is given by the business location itself - Germany.

We still train our employees ourselves, in our workshop. During the years of training, they acquire the expertise necessary to make a RIOS1931 watch strap.

It takes a trained eye and a great deal of skill to select the materials needed for the production of our watch straps. We use only the highest grades of leather available. You can be sure of a luxury product of the highest quality, authenticity and longevity when purchasing an RIOS1931 strap.







Ursprünglich und individuell

Hochwertige Uhrenarmbänder herzustellen ist bei uns noch immer lebendiges Handwerk. Wir setzen auf ursprüngliche Werte und die Bewahrung traditioneller Handwerkstechniken. Mit einem Band von RIOS1931 verleihen Sie Ihrer Uhr in einer immer gleichförmiger werdenden Welt der Massenproduktion eine individuelle Note.

Original and individual

Making high-quality watch straps is a craft that is still very present and alive. We aspire to maintain the original values of the business and to preserve traditional handicraft techniques. With an RIOS1931 watch strap, you are giving your watch a touch of the original in a world of mass production and ever more uniformity.





Handarbeit

Handmade

Aus Liebe zur Qualität

Der Herstellung unserer Armbänder widmen wir sehr viel Zeit. Alle Leder werden noch in aufwendiger Handarbeit nach den Regeln der traditionellen Täschnerkunst verarbeitet. Schonende Verfahren garantieren Ihnen naturnahe, umweltfreundliche Lederprodukte – jedes ein einzigartiges Meisterstück.

For the love of quality

We dedicate a great deal of time to making our watch straps. The leather is elaborately processed by hand in the manner of traditional leather craftsmanship. Gentle procedures guarantee you natural, environmentally-friendly, leather products - each one representing a unique masterpiece.





Handnaht

Handmade Seam

Stich für Stich von Hand

Im Gegensatz zur Maschinennaht wird bei der sogenannten Hand- oder Sattlernaht nur ein einziger Faden verwendet, der manuell mit zwei Nadeln abwechselnd von einer zur anderen Seite gezogen wird. So entsteht ein besonders gleichmäßiges Stichbild. Rund 40 Minuten dauert die Anfertigung einer solchen Naht, die einem Uhrenarmband eine höhere Lebensdauer verleiht als eine Maschinennaht. Eine exakte Handnaht erfordert das ganze Können eines Meisters seines Handwerks und stellt somit ein Stück höchster Handwerkskunst dar.

Stitch to stitch by hand

In contrast to machine sewing, the handstitched or saddler's seam uses only a single thread, which is drawn manually from one side to the other with two needles alternately. This creates a particularly even stitch pattern. It takes approximately 40 minutes to produce such a seam, which gives a watch strap a longer service life compared to machine stitching. An exact hand seam requires all the skill of a master leather artisan and thus represents a piece of the finest craftsmanship.



RIOS 1931

RIEMER OSWALD
BIEMER OSWALD

RIO 21031

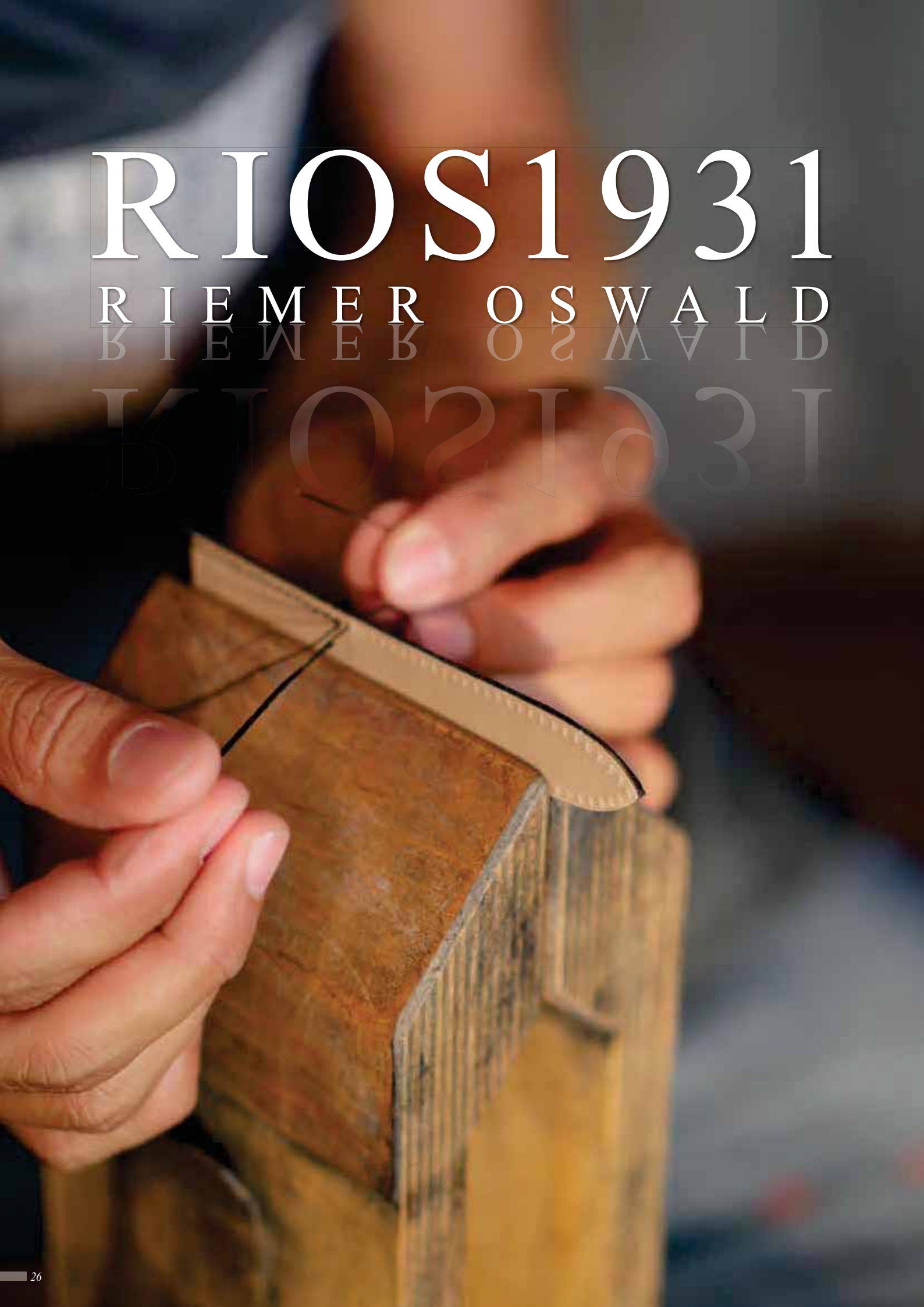

Die RIOS1931 Handnaht The RIOS1931 Saddler's Seam

*Die RIOS1931 Futterfixierung ab dem ersten Stich.
Securing the lining of the RIOS1931 from the first stitch.*



*Die RIOS1931 handvernähte Schlaufe.
The RIOS1931 hand-sewn loop.*



*Die RIOS1931-Verriegelungsnaht an der SchlieÙe,
von Hand vernäht und von innen im Dornloch verknotet.
The RIOS1931 locking stitching at the buckle,
hand-sewn and knotted on the inside through a pin hole.*

Semi-rembordiertes Band

Semi-remborde strap

ca. 50 Arbeitsschritte

Das semi-rembordierte Band ist das Ergebnis der preiswerten Massenproduktion. Das Oberleder wird nur bis zur Unterkante (nicht darunter) des Innenleders gezogen und dort versiegelt. Der Halt basiert nur auf Verklebung, die Naht ist meist reine Zierde. Die Nachteile: Wegen des ausgehärteten Klebers sind die Bänder oft sehr steif und die Kanten können aufgehen.

Die Anzahl der benötigten Arbeitsschritte kann von Hersteller zu Hersteller variieren.



approx. 50 production steps

The semi-remborded strap is used to achieve two things: low cost and mass production. The upper leather is only pulled to the bottom edge (not under) of the lining leather and sealed there. The glue is the only thing holding the strap together. The seam is only for decoration. The disadvantages: because of the cured adhesive, the straps are often very stiff and the layers are prone to separate.

The number of work steps required can vary from manufacturer to manufacturer.

Übliche Fertigungsart - Abweichungen sind möglich.
The standard production methods - variations are possible.

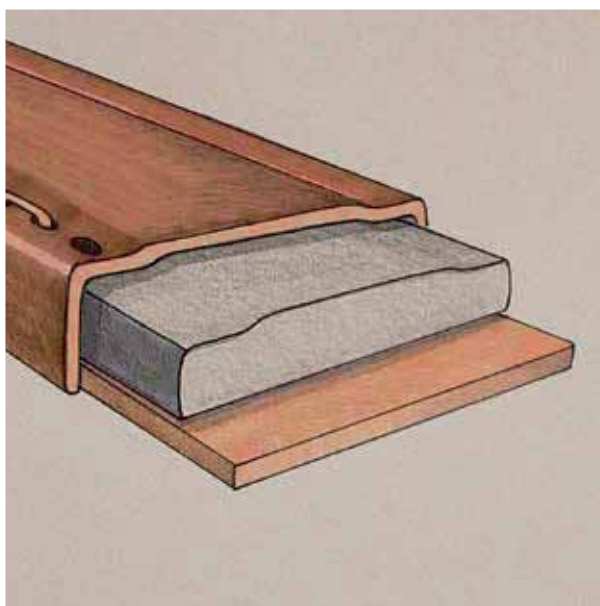

Längsschnitt
Side view

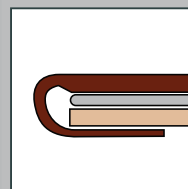

Die Enden des Oberleders sind **auf** das Futterleder aufgeklebt.

The edges of the upper leather are **glued** to the lining leather.

Längsschnitt
Side view

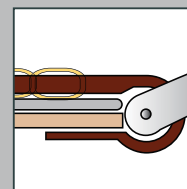

Die Schließennaht geht meist **nicht durch alle** Schichten.

The stitching usually **does not permeate all** layers.

Querschnitt
Front view - cross section

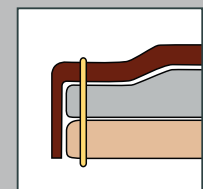

Das Oberleder schließt mit der Futterlederkante ab.

The edge of the upper leather is glued to the sides.

Schnittband

Cut strap

ca. 70 Arbeitsschritte

Wenn auch aufwendiger als beim semi-rem-bordierten Band, ist die Herstellung eines Schnittbandes eine eher einfache Methode. Das Leder wird in Bandform ausgestanzt oder zugeschnitten und verklebt. Anschließend werden die offenen Kanten gefüllt und mit Farbe versiegelt. Viele verschiedene Bänderformen sind möglich.

Die Anzahl der benötigten Arbeitsschritte kann von Hersteller zu Hersteller variieren.



approx. 70 production steps

Even though the production of the cut strap is more elaborate than the production of a semi-remborde strap, it is still a simpler method of production. The leather is cut into the shape of a strap and then glued. The open edges are then filled and coloured with dye. Many different straps are possible.

The number of work steps required can vary from manufacturer to manufacturer.

RIOS1931
RIEMER OSWALD

Eine Fertigungsart von RIOS1931
A production method for RIOS1931

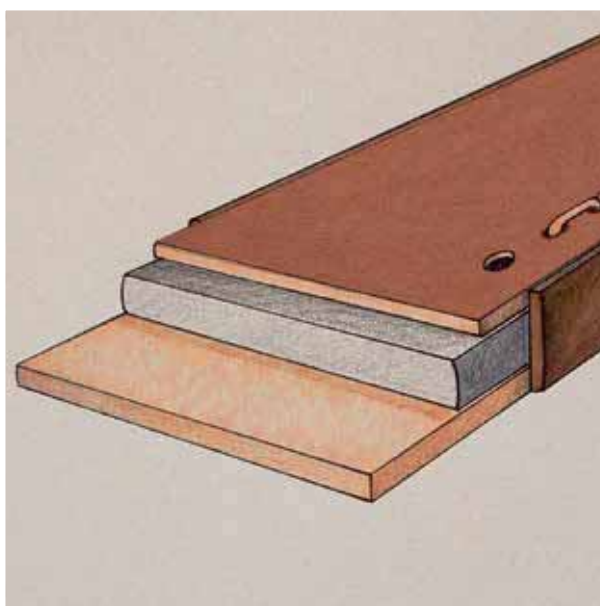

Längsschnitt
Side view

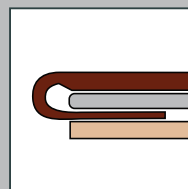

Die Enden des Ober-leders sind **unter** dem Futterleder verklebt.

The edges of the upper leather are glued **under** the lining leather.

Längsschnitt
Side view

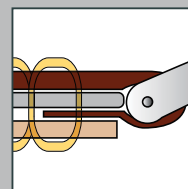

Die Schließennaht geht **durch alle** Schichten.

The stitching goes **through all** layers.

Querschnitt
Front view - cross section

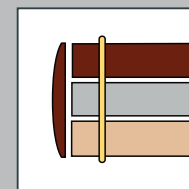

Die Schnittkante wird mit Farbe versiegelt.

The cut edge is sealed with dye.

Rembordiertes- / Vollumbugband Remborde / Full-bugg strap

ca. 140 Arbeitsschritte

Beim Rembordierten – oder Vollumbugband wird das Oberleder um ein klima- und atmungsaktives, natürliches Baumwollvlies geschlagen und verklebt. Anschließend wird das eingeschlagene Oberleder fasertief mit dem Futterleder verleimt, sodass das Eindringen von Bakterien vermieden wird. Am Ende werden alle Schichten miteinander vernäht. Das RIOS1931 Vollumbugband ist ähnlich wie bei einem »Goodyear welted«, bzw. »rahmengenähten« Schuh weicher, gleichzeitig dabei aber auch stabiler und haltbarer.



approx. 140 production steps

In the production of a remborde or full-bugg strap, the upper leather is folded under a breathable, natural cotton fleece and then glued in place. The folded upper layer is glued to the lining leather as far down as the fabric fibres to prevent penetration by bacteria. Finally, all the layers are stitched together. The RIOS1931 full-bugg strap is softer, similar to a »Goodyear welted« or »frame-stitched« shoe, but at the same time more stable and long lasting.

RIOS1931
RIEMER OSWALD

Eine Fertigungsart von RIOS1931
A production method for RIOS1931

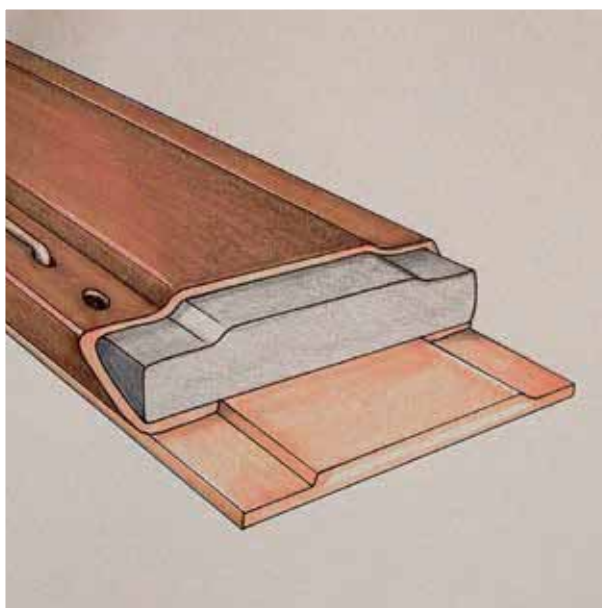

Längsschnitt
Side view

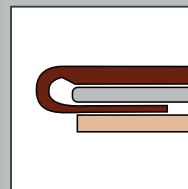

Die Enden des Oberleders sind **unter** dem Futterleder verklebt.

The edges of the upper leather are glued **under** the lining leather.

Längsschnitt
Side view

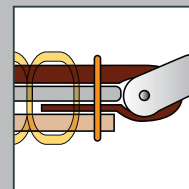

Die Schließennaht geht **durch alle** Schichten.

The stitching goes **through all** layers.

Querschnitt
Front view - cross section

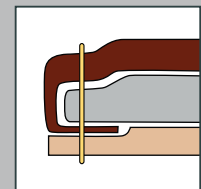

Das Oberleder liegt fest vernäht **unter** dem Futterleder.

The upper leather is stitched securely **under** the lining leather.

Rembordiertes- / Vollumbugband

Remborde / Full-bugg strap

»Art Manuel«



ca. 172 Arbeitsschritte

Bei der High-End-Variante »Art Manuel« wird ausgehend von dem RIOS1931 Vollumbugband, das ähnlich einem »Goodyear welted«, bzw. »rahmengenähten« Schuh gefertigt ist, noch zusätzlich eine Lederauflage platziert. Danach wird das Band geprägt, die Kanten werden mit Hitze verschliffen mit Sandpapier bearbeitet und gefüllt sowie fünffach mit Kantenfarbe gestrichen. Die Schlaufen sind handvernäht. Viele »Art Manuel« Modelle haben zudem eine echte Handnaht (Sattlernah).



approx. 172 production steps

The high-end »Art Manuel« technique used for the RIOS1931 full-bugg strap is similar to a »Goodyear welted« or »frame-stitched« shoe, with an additional leather sheath. The strap is then embossed; the edges are smoothed with heat, sanded down and painted 5 times with edge dye. The loops are hand stitched. Many of the »Art Manuel« models also have true saddle stitching (hand seam).

RIOS1931
RIEMER OSWALD

Eine Fertigungsart von RIOS1931
A production method for RIOS1931



Längsschnitt
Side view

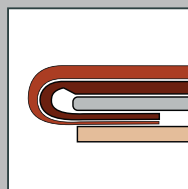

Die Enden der Auflage und des Ledermantels sind **unter** dem Futterleder verklebt.

The edges of the upper leather are glued **under** the lining leather.

Längsschnitt
Side view

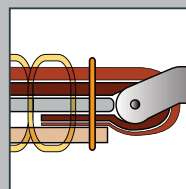

Die Schließennaht geht **durch alle** Schichten.

The stitching goes **through all** layers.

Querschnitt
Front view - cross section

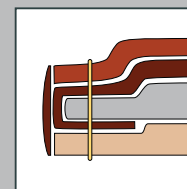

Das Oberleder liegt fest vernäht unter dem Futterleder.

The upper leather is stitched tightly under the leather lining.

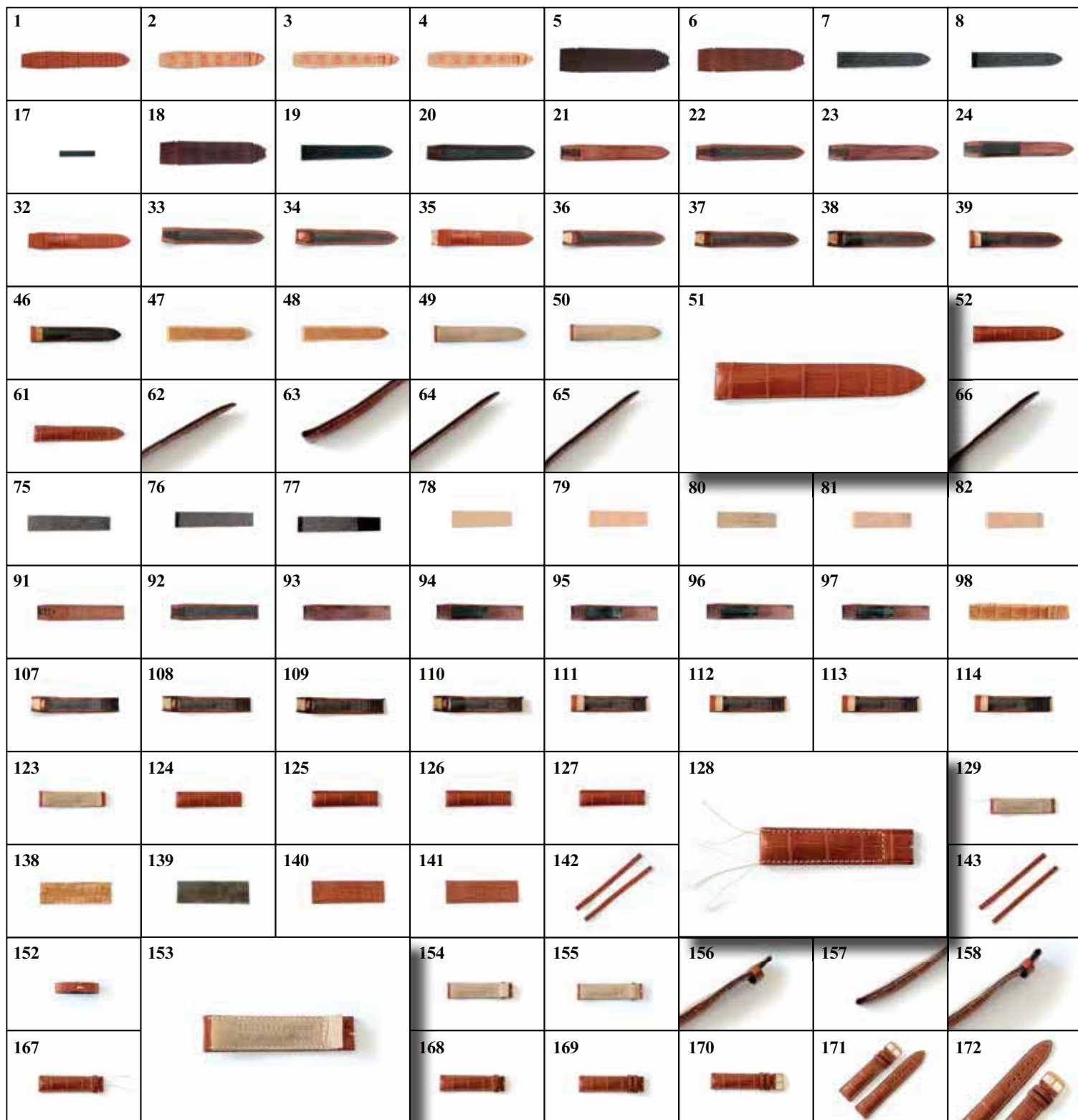

1 Lang = Oberleder ausstanzen
 2 Lang = Oberleder egalisieren
 3 Lang = Oberleder Seiten anscharfen
 4 Lang = Oberleder Spitze anscharfen
 5 Lang = Mantelleider ausstanzen
 6 Lang = Mantelleider egalisieren
 7 Lang = Natürliches Baumwollvlies ausstanzen
 8 Lang = Natürliches Baumwollvlies Anstoß anscharfen
 9 Lang = Futterleder ausstanzen
 10 Lang = Futterleder egalisieren
 11 Lang = Futterleder Seiten anscharfen
 12 Lang = Futterleder Spitze anscharfen
 13 Lang = Futterleder Anstoß anscharfen
 14 Lang = Hightech Unterschaum ausstanzen
 15 Lang = Hightech Unterschaum auf Maß kürzen
 16 Lang = Hightech Unterschaum anscharfen
 17 Lang = Hightech Oberschaum ausstanzen
 18 Lang = Mantelleider einleimen

19 Lang = Natürliches Baumwollvlies einleimen
 20 Lang = Mantelleider um Baumwollvlies umbiegen
 21 Lang = Oberseite Buggband Farbe abscharfen
 22 Lang = Unterseite Buggband Farbe abscharfen
 23 Lang = Buggbandoberseite einleimen
 24 Lang = Hightech Unterschaum aufkleben
 25 Lang = Hightech Unterschaum einleimen
 26 Lang = Hightech Oberschaum aufkleben
 27 Lang = Hightech Oberschaum einleimen
 28 Lang = Buggbandspitze mit Powerkleber einleimen
 29 Lang = Oberleder einleimen
 30 Lang = Oberleder auf Buggband aufkleben
 31 Lang = Buggbandspitze andrücken
 32 Lang = Band auf Länge kürzen
 33 Lang = Andrücken bei Anstoß
 34 Lang = Abscharfen bei Anstoß
 35 Lang = Farbe von Oberleder abscharfen bei Anstoß
 36 Lang = Lappenende bei Anstoß rausscharfen

37 Lang = Lappenende bei Anstoß anscharfen
 38 Lang = Lappenende bei Anstoß mit Powerkleber einleimen
 39 Lang = Lappen bei Anstoß einschlagen
 40 Lang = Lappen bei Anstoß in der Mitte andrücken
 41 Lang = Lappen bei Anstoß an den Seiten andrücken
 42 Lang = Band von Kleberesten putzen
 43 Lang = Band prägen
 44 Lang = Bandkanten schleifen
 45 Lang = Buggbandunterseite einleimen
 46 Lang = Buggbandunterseite Spitze mit Powerkleber einleimen
 47 Lang = Futterleder einleimen
 48 Lang = Futterlederspitze mit Powerkleber einleimen
 49 Lang = Futterleder mit Buggband zusammenlegen
 50 Lang = Buggbandspitze andrücken
 51 Lang = Buggband putzen
 52 Lang = Band vorprägen
 53 Lang = Bandkanten schleifen
 54 Lang = Stichanfang und Ende anzeichnen

55 Lang = Nähen
 56 Lang = Faden aufziehen
 57 Lang = Faden einleimen
 58 Lang = Faden einziehen und putzen
 59 Lang = Faden abschneiden
 60 Lang = Löcher stanzen
 61 Lang = Band nachprägen
 62 Lang = Bandkanten glattpolieren
 63 Lang = Anstoß Federstegloch rollieren
 64 Lang = Vorlack auftragen
 65 Lang = Kante polieren
 66 Lang = Kantenfarbe auftragen (5-fach)
 67 Lang = Kante nachpolieren
 68 Lang = Anstoß Federstegloch nachrollieren
 69 Kurz = Oberleder ausstanzen
 70 Kurz = Oberleder egalisieren
 71 Kurz = Oberleder Seiten anscharfen
 72 Kurz = Oberleder Schließeenseite anscharfen

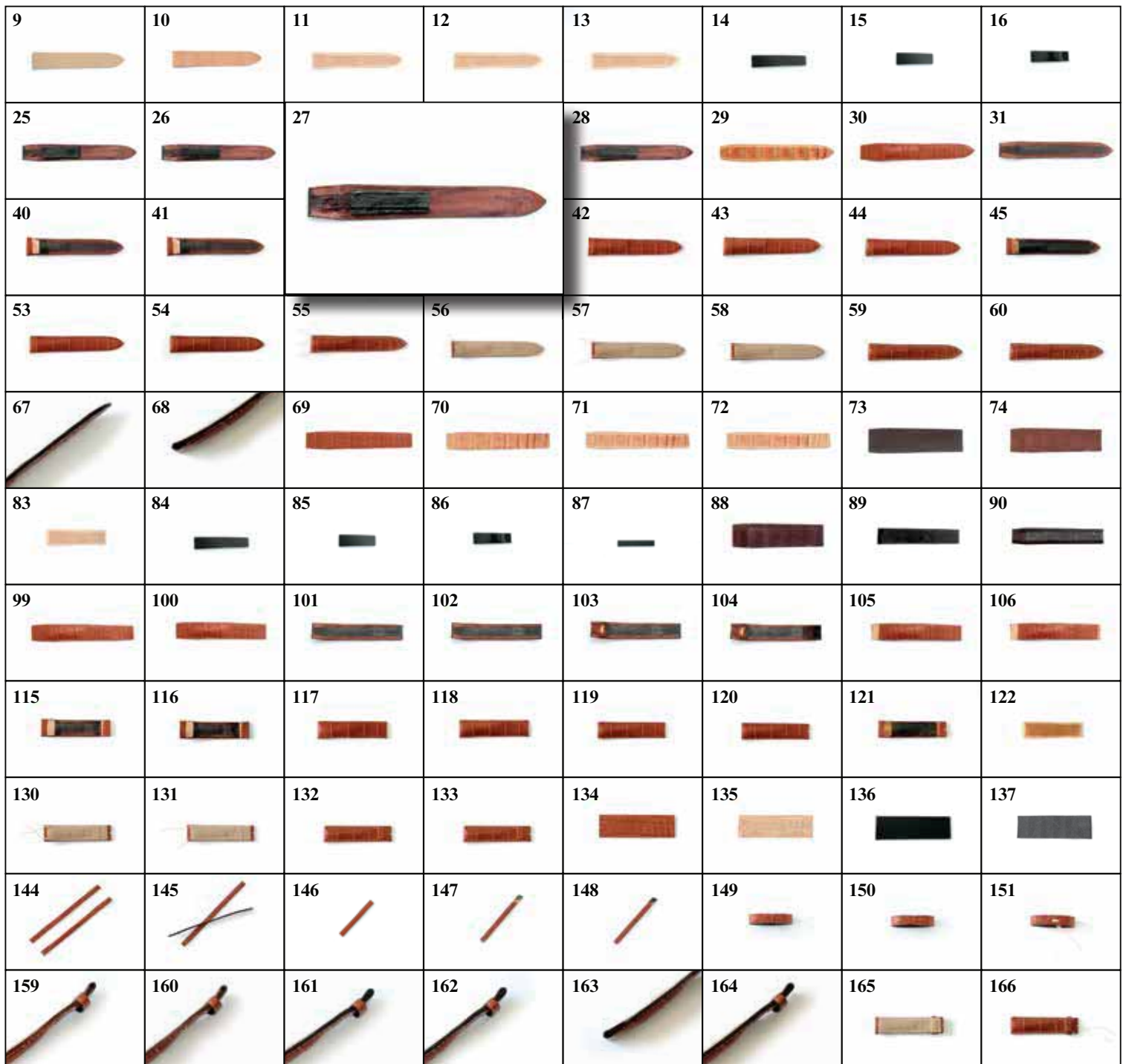

73 Kurz = Mantelleder ausstanzen
 74 Kurz = Mantelleder egalisieren
 75 Kurz = Natürliches Baumwollvlies ausstanzen
 76 Kurz = Natürliches Baumwollvlies Anstoß anschrägen
 77 Kurz = Natürliches Baumwollvlies Schließeenseite anschrägen
 78 Kurz = Futterleder ausstanzen
 79 Kurz = Futterleder egalisieren
 80 Kurz = Futterleder mit Namen stempeln
 81 Kurz = Futterleder Anstoß anschrägen
 82 Kurz = Futterleder Schließeenseite anschrägen
 83 Kurz = Futterleder Seiten anschrägen
 84 Kurz = Hightech Unterschaum ausstanzen
 85 Kurz = Hightech Unterschaum auf Maß kürzen
 86 Kurz = Hightech Unterschaum anschrägen
 87 Kurz = Hightech Oberschaum ausstanzen
 88 Kurz = Mantelleder einleimen
 89 Kurz = Natürliches Baumwollvlies einleimen
 90 Kurz = Mantelleder um Baumwollvlies umbiegen
 91 Kurz = Oberseite Buggband Farbe abschrägen
 92 Kurz = Unterseite Buggband Farbe abschrägen
 93 Kurz = Buggbandoberseite einleimen
 94 Kurz = Hightech Unterschaum aufkleben
 95 Kurz = Hightech Unterschaum einleimen
 96 Kurz = Hightech Oberschaum aufkleben
 97 Kurz = Hightech Oberschaum einleimen

98 Kurz = Oberleder einleimen
 99 Kurz = Oberleder auf Buggband aufkleben
 100 Kurz = Band auf Länge kürzen
 101 Kurz = Andrücken bei Anstoß
 102 Kurz = Andrücken bei Schließeenseite
 103 Kurz = Abschrägen bei Anstoß
 104 Kurz = Abschrägen bei Schließeenseite
 105 Kurz = Farbe von Oberleder abschrägen bei Anstoß
 106 Kurz = Farbe von Oberleder abschrägen bei Schließeenseite
 107 Kurz = Lappende bei Anstoß rausschrägen
 108 Kurz = Lappende bei Anstoß anschrägen
 109 Kurz = Lappende bei Anstoß bei Schließeenseite anschrägen
 110 Kurz = Lappende bei Anstoß mit Powerkleber einleimen
 111 Kurz = Lappen bei Anstoß einschlagen
 112 Kurz = Lappen bei Anstoß in der Mitte andrücken
 113 Kurz = Lappen bei Anstoß an den Seiten andrücken
 114 Kurz = Lappende bei Schließeenseite mit Powerkleber einleimen
 115 Kurz = Lappen bei Schließeenseite einschlagen
 116 Kurz = Lappen bei Schließeenseite andrücken
 117 Kurz = Band von Kleberesten putzen
 118 Kurz = Band prägen
 119 Kurz = Bandkanten schleifen
 120 Kurz = Dornloch stanzen
 121 Kurz = Buggbandunterseite einleimen
 122 Kurz = Futterleder einleimen

123 Kurz = Futterleder mit Buggband zusammenlegen
 124 Kurz = Buggband putzen
 125 Kurz = Band vorprägen
 126 Kurz = Bandkante schleifen
 127 Kurz = Stichenfang und Ende anzeichnen
 128 Kurz = Nähen
 129 Kurz = Faden aufziehen
 130 Kurz = Faden einleimen
 131 Kurz = Faden einziehen und putzen
 132 Kurz = Faden abschneiden
 133 Kurz = Band nachprägen
 134 Schl = Oberleder ausstanzen
 135 Schl = Oberleder egalisieren
 136 Schl = Innenleder ausstanzen
 137 Schl = Innenleder egalisieren
 138 Schl = Oberleder einleimen
 139 Schl = Innenleder einleimen
 140 Schl = Ober und Innenleder zusammenlegen
 141 Schl = Ober und Innenleder andrücken
 142 Schl = Schlaufen schneiden
 143 Schl = Schlaufen prägen
 144 Schl = Schlaufenkanten schleifen
 145 Schl = Schlaufenkanten streichen
 146 Schl = Schlaufe auf Länge kürzen
 147 Schl = Schlaufe anschrägen

148 Schl = Schlaufe einleimen
 149 Schl = Schlaufe zusammenleimen
 150 Schl = Stichenfang und Ende anzeichnen
 151 Schl = Schlaufe nähen
 152 Schl = Schlaufenfaden verleimen und abschneiden
 153 Kurz = Futterinnenseite einleimen bei Schließeenseite
 154 Kurz = Feste Schlaufe einsetzen
 155 Kurz = Futter bei Schließeenseite aufkleben
 156 Kurz = Bandkanten glattpolieren
 157 Kurz = Anstoß Federstegloch rollieren
 158 Kurz = Schließeenseite Federstegloch rollieren
 159 Kurz = Vorlack auftragen
 160 Kurz = Kante polieren
 161 Kurz = Kantenfarbe auftragen (5-fach)
 162 Kurz = Kante nachpolieren
 163 Kurz = Anstoß Federstegloch nachrollieren
 164 Kurz = Schließeenseite Federstegloch nachrollieren
 165 Kurz = Stichenfang und Ende für Schließeinriegelung anzeichnen
 166 Kurz = Schließeinriegelung nähen
 167 Kurz = Faden bei Schließeinriegelung verketten
 168 Kurz = Faden einkleben und abschneiden
 169 Kurz = Lose Schlaufe aufziehen
 170 Kurz = Schließe einbauen
 171 = Hochzeit kurzes und langes Bandteil
 172 = Bandoberfläche polieren

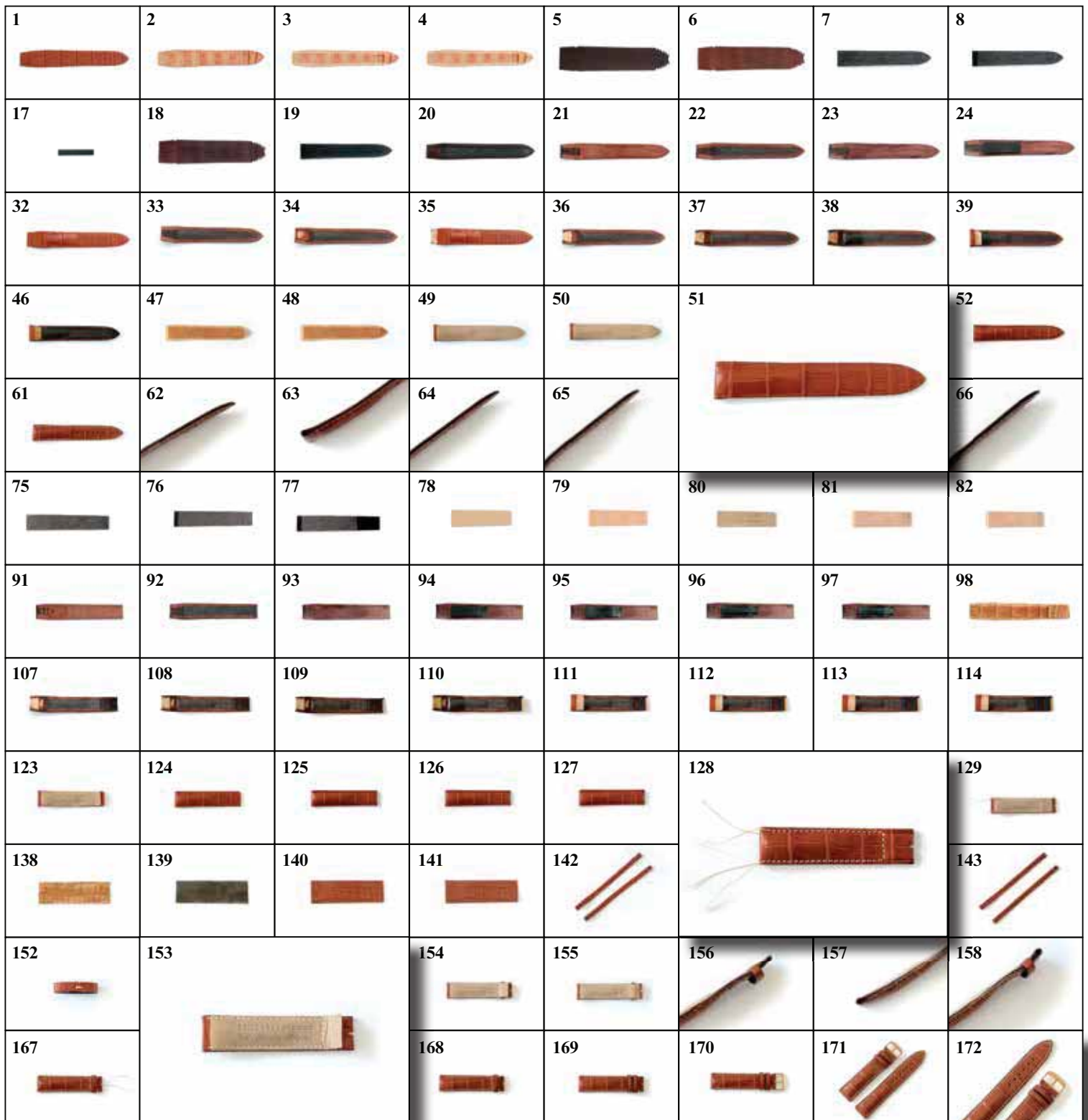

1 Long = punch out upper leather
 2 Long = even out upper leather
 3 Long = skive edges of upper leather
 4 Long = skive lace of upper leather
 5 Long = punch out casing leather
 6 Long = even out casing leather
 7 Long = punch out natural cotton fleece
 8 Long = skive natural cotton fleece
 9 Long = punch out padding leather
 10 Long = even out padding leather
 11 Long = skive edges of padding leather
 12 Long = skive lace of padding leather
 13 Long = skive ends of padding leather
 14 Long = punch out high-tech lower foam
 15 Long = high-tech lower foam in adjustment
 16 Long = skive high-tech lower foam
 17 Long = punch out high-tech upper foam
 18 Long = glue casing leather

19 Long = glue natural cotton fleece
 20 Long = fold casing leather over cotton fleece
 21 Long = bevel upper side bugstrap color
 22 Long = bevel underside bugstrap color
 23 Long = glue upper side of bugstrap
 24 Long = adhere high-tech lower foam
 25 Long = glue high-tech lower foam
 26 Long = adhere high-tech upper foam
 27 Long = glue high-tech upper foam
 28 Long = glue lace of bugstrap with extra-strong glue
 29 Long = glue upper leather
 30 Long = adhere upper leather to bugstrap
 31 Long = fix lace of bugstrap
 32 Long = shorten strap to length
 33 Long = fix at lace
 34 Long = bevel at lace
 35 Long = bevel color of upper leather at lace
 36 Long = skive out end of flap at lace

37 Long = chamfer end of flap at lace
 38 Long = glue end of flap at lace with extra-strong glue
 39 Long = fold in flap at lace
 40 Long = press on flap at lace in the middle
 41 Long = press on flap at lace on the edges
 42 Long = clear strap off rest of glue
 43 Long = emboss strap
 44 Long = grind edges of strap
 45 Long = glue underside of bugstrap
 46 Long = glue underside of bugstrap lace with extra-strong glue
 47 Long = glue padding leather
 48 Long = glue lace of padding leather with extra-strong glue
 49 Long = fold up padding leather and bugstrap
 50 Long = press on lace of bugstrap
 51 Long = clean bugstrap
 52 Long = pre-emboss strap
 53 Long = grind edges of strap
 54 Long = indicate beginning and end of stitching

55 Long = sew
 56 Long = thread yarn
 57 Long = glue yarn
 58 Long = lace and clean yarn
 59 Long = cut off yarn
 60 Long = cut out holes
 61 Long = re-emboss strap
 62 Long = smooth edges of strap
 63 Long = tumble lace of hole of pin
 64 Long = apply undercoating varnish
 65 Long = polish edge
 66 Long = apply color to edges (fivefold)
 67 Long = polish edge
 68 Long = tumble lace of hole of pin again
 69 Short = punch out upper leather
 70 Short = even out upper leather
 71 Short = skive sides of upper leather
 72 Short = skive upper leather at the side of fastening

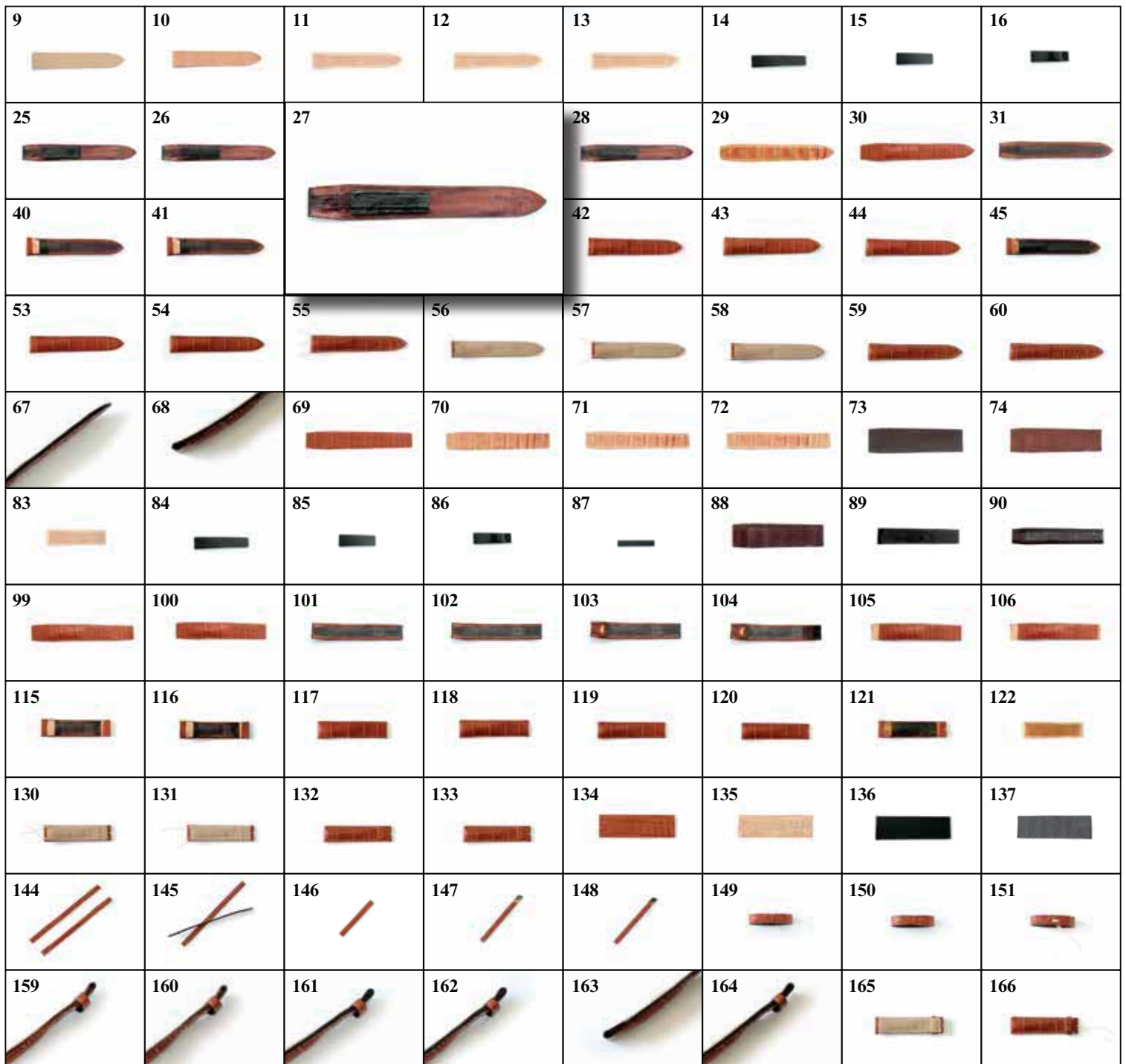

73 Short = punch out casing leather
 74 Short = even out casing leather
 75 Short = punch out natural cotton fleece
 76 Short = skive lace of natural cotton fleece
 77 Short = skive natural cotton fleece at side of fastening
 78 Short = punch out padding leather
 79 Short = even out padding leather
 80 Short = stamp padding leather with name
 81 Short = skive padding leather lace
 82 Short = skive padding leather at side of fastening
 83 Short = skive edges of padding leather
 84 Short = punch out high-tech lower foam
 85 Short = shorten high-tech lower foam in adjustment
 86 Short = skive high-tech lower foam
 87 Short = punch out high-tech upper foam
 88 Short = glue casing leather
 89 Short = glue natural cotton fleece
 90 Short = fold casing leather over cotton fleece
 91 Short = bevel color of upper side of buggstrap
 92 Short = skive color of underside of buggstrap
 93 Short = glue upper side of buggstrap
 94 Short = adhere high-tech lower foam
 95 Short = glue high-tech lower foam
 96 Short = adhere high-tech upper foam
 97 Short = glue high-tech upper foam

98 Short = glue upper leather
 99 Short = adhere upper leather to buggstrap
 100 Short = shorten strap to length
 101 Short = press at lace
 102 Short = press at side of fastening
 103 Short = bevel at lace
 104 Short = bevel at side of fastening
 105 Short = bevel color of upper leather at lace
 106 Short = bevel color of upper leather at side of fastening
 107 Short = skive out end of flap at lace
 108 Short = chamfer end of flap at lace
 109 Short = chamfer end of flap at lace at side of fastening
 110 Short = glue end of flap at lace with extra-strong glue
 111 Short = fold in flap at lace
 112 Short = press on flap at lace in the middle
 113 Short = press on flap at lace at edges
 114 Short = glue end of flap at side of fastening with extra-strong glue
 115 Short = fold in flap at side of fastening
 116 Short = press on flap at side of fastening
 117 Short = clean strap off rest of glue
 118 Short = emboss strap
 119 Short = grind edges of strap
 120 Short = cut out hole for prickie
 121 Short = glue underside of buggstrap
 122 Short = glue padding leather

123 Short = fold up padding leather and buggstrap
 124 Short = clean buggstrap
 125 Short = pre-emboss strap
 126 Short = grind edge of strap
 127 Short = indicate beginning and end of stitching
 128 Short = sew
 129 Short = thread yarn
 130 Short = glue yarn
 131 Short = lace and clean yarn
 132 Short = cut off yarn
 133 Short = re-emboss strap
 134 Loop = punch out upper leather
 135 Loop = even out upper leather
 136 Loop = punch out inner leather
 137 Loop = even out inner leather
 138 Loop = glue upper leather
 139 Loop = glue inner leather
 140 Loop = fold up upper and inner leather
 141 Loop = press upper to inner leather
 142 Loop = cut loops
 143 Loop = emboss loops
 144 Loop = grind edges of loops
 145 Loop = coat edges of loops
 146 Loop = shorten loops to length
 147 Loop = skive loop

148 Loop = glue loop
 149 Loop = glue loop
 150 Loop = indicate beginning and end of stitching
 151 Loop = sew loop
 152 Loop = glue and cut yarn of loop
 153 Short = glue inside of padding at this side of fastening
 154 Short = set in loop strongly
 155 Short = adhere padding at the side of fastening
 156 Short = smooth edges of strap
 157 Short = tumble lace at hole of pin
 158 Short = tumble hole of pin at side of fastening
 159 Short = apply undercoating varnish
 160 Short = polish edge
 161 Short = apply color to edges (fivefold)
 162 Short = polish edge
 163 Short = tumble lace at hole of pin again
 164 Short = tumble side of fastening at hole of pin
 165 Short = indicate beginning and end of bar of fastening
 166 Short = sew bar of fastening
 167 Short = knot yarn at bar of fastening
 168 Short = stick in and cut off yarn
 169 Short = tear loose loop open
 170 Short = insert fastening
 171 = Marriage of short and long part of strap
 172 = polish surface of strap

Rembordiertes- / Vollumbugband Remborde / Full-bugg strap »Art Manuel«



Zusätzliche Lederauflage
Extra leather layer

Gebogter Ledermantel
Leather sheath

Baumwollvlies
Cotton fleece

Fünffach Kantenfarbe
5 layers of edge dye

Sattlernah
Saddlers' Seam

Futterleder
Leather lining



RIOS1931 | *Handnaht* |

In ca. 40 Minuten entsteht eine Bandnaht in meisterlicher Handwerkskunst mit extremer Haltbarkeit und perfektem Stichbild.



RIOS1931 | *Saddler's Seam* |

It takes a master craftsman about 40 minutes to complete a perfectly stitched saddler's seam (hand seam) that will last and last.

RIOS1931 | *Wasserresistent* |

Wasserresistenz durch Hightech-Materialien oder hydrophobiertes Oberleder, Einlagenmaterial und Futterleder.



RIOS1931 | *Water resistant* |

Water resistance achieved by high-tech materials or a hydro-finished upper leather, intermediate layer and leather lining.

RIOS1931 | *Spangensband* |

Schnelles, einfaches Wechseln mit dem Spangensystem. Der Federsteg muss nicht ausgebaut werden - ideal auch bei festen Stegen.



RIOS1931 | *Clasp strap* |

The clasp fastening system is quick and easy to replace. The pin does not have to be removed - also ideal for fixed (solid) lugs.

RIOS1931 | *Art Manuel* |

Die High-End-Variante »Art Manuel« wird ähnlich einem »Goodyear welted«, bzw. »rahmengenähten« Schuh gefertigt. Edle Handwerkskunst aus Tradition.



RIOS1931 | *Art Manuel* |

The high-end »Art Manuel« strap is hand finished similarly to a »Goodyear welted« or »frame-stitched« shoe. The finest of traditional craftsmanship.

RIOS1931 | *vegetabil gegerbt* |

Mit pflanzlichen Stoffen gegerbtes Ober- und Futterleder. Bearbeitet nach altbewährten Rezepturen und mit Extrakten aus gemahlenden Hölzern, Rinden, Blättern und Früchten. Durch natürliche Fette und Wachse entstehen die hervorragende Weichheit und der runde, sympathische Griff. Die pflanzlichen Gerbstoffe verleihen dem Band den angenehmen, ledertypischen Duft nach Bienenhonig und Tabak.



RIOS1931 | *Organically Tanned Leather* |

Upper and lining leather is tanned with vegetable substances processed according to traditional formulas with extracts of groundwood, bark, leaves and fruits. The extraordinary softness and pleasant touch result from the use of natural fats and waxes. The vegetable tanning substances give the watch strap a typical leather fragrance of bees wax and tobacco.

RIOS1931 | *Bio-Uhrenarmbänder* |

Sämtliche Schritte innerhalb der Produktionskette sind ökologisch nachhaltig und biozertifiziert. Die natürlich und pflanzlich gegerbten, absolut weichen Leder verleihen den Bändern dieser Serie eine exzellente Haptik und hohen Tragekomfort.



RIOS1931 | *Organic Watch Straps* |

All steps within the production chain are ecologically sustainable and certified organic. The natural and vegetable-tanned, absolutely soft leather give the straps of this series an excellent feel and high wearing comfort.

Chromfrei • Natürlich & pflanzlich gegerbt • Allergikerfreundlich • Artgerechte Tierhaltung • Geschlossene Nachhaltigkeitskette • Leder von deutschen Rindern aus anerkannten Biobetrieben • »Biokreis«, ECARF + IVN zertifiziert

Chromium-free • Natural & vegetable-tanned leather • Allergy-friendly • Animal welfare approved • Sustainability chain • Leather from German cattle from approved organic farms • «Biokreis», ECARF + IVN certified



Ganz nach Ihren Wünschen...

According to your wishes...



Einzelstücke und Ersatzbänder

Gern stellen wir Ihnen Ihre persönliche Sonderanfertigung her. Individuelle Formen, wie besondere Breiten und Längen, oder spezielle Farb- und Lederwünsche sind kurzfristig realisierbar. Darüber hinaus fertigen wir Ihnen auch Ersatzbänder für alle gängigen Uhrentypen an.

Individual straps and replacements

We are happy to produce a strap based on your personal requirements. Individual requirements, such as special widths and lengths, or a specific colour or leather can be fulfilled in minimal time. In addition, we can also make replacement straps for all popular types of watches.

Mehr als nur Standard...

More than just standard...

Individuell bis ins Detail

Bei der Entwicklung unserer Produkte gehen wir gern einen Schritt weiter. So haben wir für unsere RIOS1931 Uhrenarmbänder mit Alligatoren-Prägung eine eigens, von einem italienischen Künstler entworfene Prägeplatte anfertigen lassen, die eine wunderbar naturgetreue und charakteristische Prägung unserer Uhrenarmbänder garantiert.



Individual down to the last detail

In the evolution of our products, we go that extra step. For instance, we commissioned an Italian designer to produce an embossing plate with a wonderfully natural and distinctive imprint for our RIOS1931 alligator embossed watch strap.





Offen für außergewöhnliche Ideen

Bei RIOS1931 sind Ihren Wünschen und Vorstellungen, was Ihre individuellen Projekte betrifft, so gut wie keine Grenzen gesetzt. Für ganz besondere Bänder mit dem gewissen Extra sind wir der richtige Ansprechpartner: Wir entwickeln und fertigen für Sie außergewöhnliche Uhrenarmbänder, basierend auf Ihren Ideen und Wünschen, Form-, Farb- und Materialvorstellungen.

**Ganz gleich, was für ein Band Ihnen vorschwebt:
Sprechen Sie mit uns! Wir beraten Sie gern!**



Open to unusual ideas

For the RIOS1931, virtually no limits are set on your requirements and ideas for your individual projects. We are your first port of call for very special straps with that special something extra. We design and make exceptional watch straps based on your ideas and wishes regarding shape, colour and materials.

**No matter what sort of watch strap you have in mind:
Contact us! We'd be happy to advise you!**

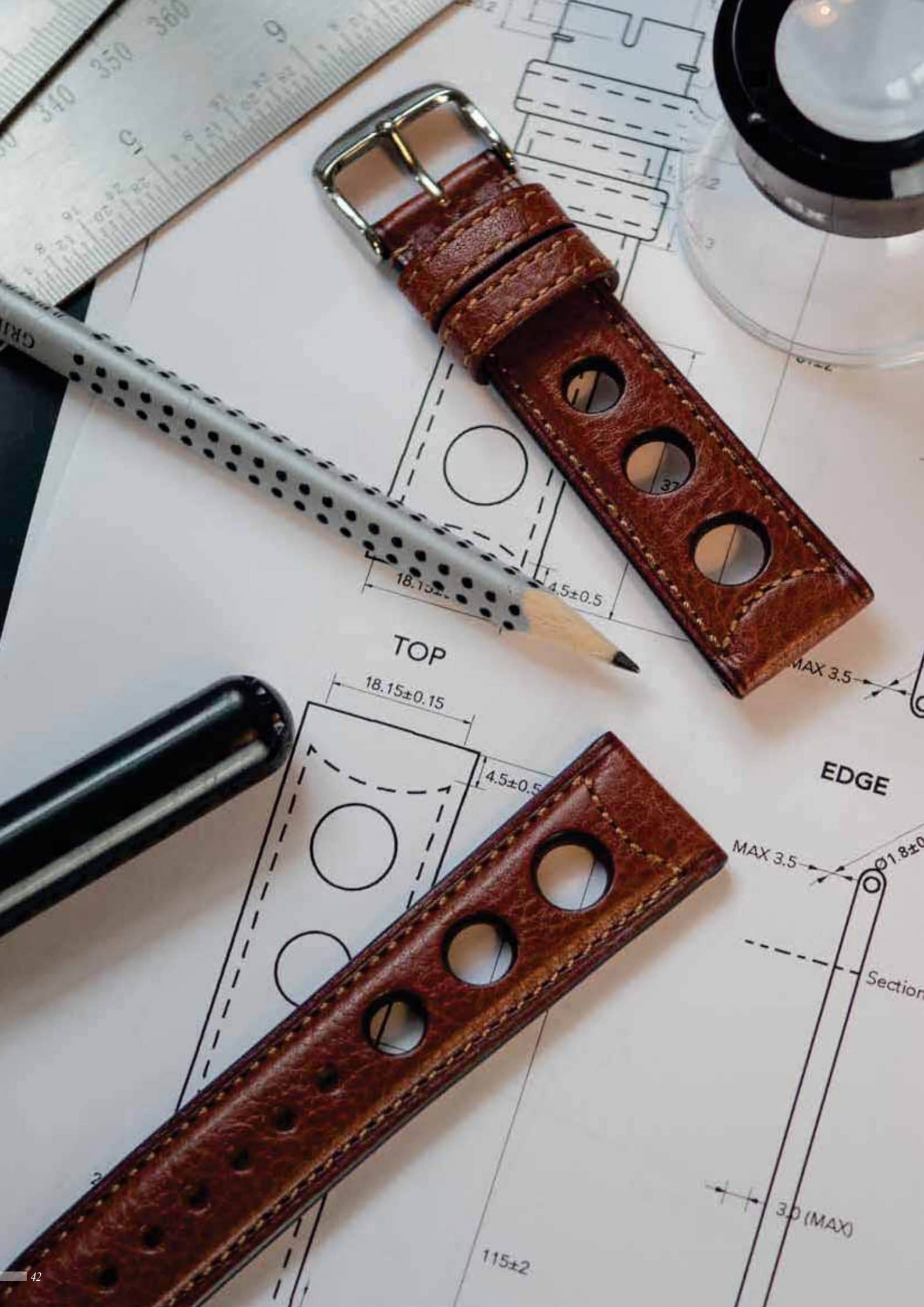

TOP

18.15±0.15

4.5±0.5

MAX 3.5

EDGE

MAX 3.5

Ø1.8±0.05

Section

3.0 (MAX)

115±2

Erfahren & kompetent...

Experienced & competent...

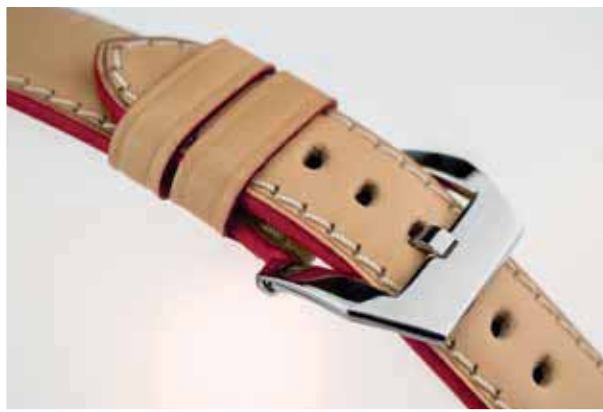

Exklusivserien für Uhrenhersteller

RIOS1931 ist ein kompetenter und zuverlässiger Partner der Uhrenindustrie in der Entwicklung und Produktion hochwertiger Uhrenarmbänder.

Wir sind stolz seit vielen Jahren das Vertrauen bei der Fertigung von OEM Bänder für viele namhafte Uhrenhersteller auf der ganzen Welt genießen zu können.

Exclusive series for watch manufacturers

RIOS1931 is a professional and reliable partner for the watch industry in the design and production of high-quality watch straps.

We are proud to have enjoyed for many years an excellent relationship with many of the renowned watch manufacturers from all over the world in the production of OEM watch straps.

Verantwortung Responsibility

| Umwelt | unbedenklich und schadstofffrei

RIOS1931-Uhrenarmbänder sind gesundheitlich unbedenkliche und artenschutzrechtlich einwandfreie Artikel. Wir verwenden kautschukartige Leime, Verschlüsse und Schließen aus Edelstahl sowie weitgehend antiallergische Futterleder für zusätzlichen Schutz sind diese mit einer speziellen Oberflächenbeschichtung versehen, die wir zusammen mit unserer Gerberei entwickelt haben.

Alle verwendeten Leder erfüllen selbstverständlich die gesetzlichen Richtlinien, wie zum Beispiel für PCP oder gesundheitsschädliche AZO-Farbstoffe, und entsprechen den gesetzlichen Formaldehyd-Bestimmungen.

| Environment | Free of pollutants and harmless to health

RIOS1931 watch straps are harmless to health and compliant with protection of species regulations. We use rubber-type glues, fastenings made of stainless steel, and mainly anti-allergic lining leather with an additional special surface coating for added protection, which we have developed in our tannery.

It goes without saying that all the leathers we use comply with the legal regulations, for example, those for PCP or harmful AZO dyes, and they comply with the legal provisions for Formaldehyde.



| Arten |
artenschutzrechtlich
einwandfrei

Unsere internen Grundsätze über Materialauswahl und Fertigung erfüllen bereits heute die Anforderungen von morgen. Sämtliche RIOS1931-Reptilleder-Uhrenarmbänder tragen die IRV-Fahne. Der Garant dafür, dass das Leder ein artenschutzrechtlich einwandfreier Artikel ist und nach den Bestimmungen des Washingtoner Artenschutz-Abkommens erworben wurde.



| Species |
Protection of species
compliant

Our company policy on the selection of materials and manufacturing meets today the requirements of tomorrow. All the RIOS1931 reptile leather watch straps bear the label of the IRV. It guarantees that the leather is a conservation of species compliant article and was purchased under the provisions of the Washington Conservation Agreement.

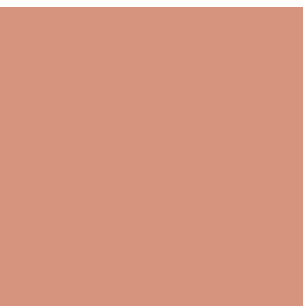

Für weitere Fragen:
If you have any questions:

Internationaler Reptillederverband e.V. Offenbach
Berliner Straße 48 | 63065 Offenbach | Germany
info@irv-ra.de
www.irv-ra.de

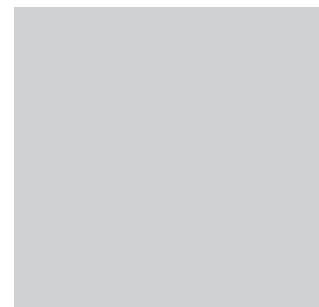

The image features two crocodile leather belts with silver buckles, positioned diagonally across the frame. The background is a close-up of crocodile skin, showing its characteristic diamond-shaped scales. The lighting is dramatic, highlighting the texture of the leather and the metallic sheen of the buckles. The buckles have the brand name 'RIOS' engraved on them.

Reptilien / Exoten

Reptiles / Exotics

Seite | Page 47
Mod. 276



Länge Length (mm)		M	
		114	82
Breite Width			
Anstoß / Lug	Schließe / Buckle		
18 mm	16 mm	●	
19 mm	16 mm	●	
20 mm	16 mm	●	
20 mm	18 mm	●	
22 mm	18 mm	▲	

Form Querschnitt | Cross-section:



Mod. 277 | Windsor

DE: Echt Alligatorenleder in glanz, Fullcut | »Art Manuel« | »Handnaht« | Naht: Ton in Ton | Bandstärke: ca. 5,5 mm auf 3,0 mm

ENG: Genuine Alligator Leather, glossy finish, fullcut | »Art Manuel« | »Saddler's Seam (Hand Seam)« | Seam: matching stitching | Thickness of strap: approx. 5.5 mm to 3.0 mm



277 05
mahagani
mahogany

277 07
mokka
mocha

277 12
ozeanblau
ocean blue

277 13
schwarz
black



Länge Length (mm)		M	
		114	82
Breite Width			
Anstoß / Lug	Schließe / Buckle		
18 mm	16 mm	●	
19 mm	16 mm	●	
20 mm	16 mm	●	
20 mm	18 mm	●	
21 mm	18 mm	▲	
22 mm	18 mm	▲	

Form Querschnitt | Cross-section:



Mod. 276 | President

DE: Echt Alligatorenleder in matt, Fullcut | »Art Manuel« | »Handnaht« | Naht: Ton in Ton | Bandstärke: ca. 5,5 mm auf 3,0 mm

ENG: Genuine Alligator Leather, matt finish, fullcut | »Art Manuel« | »Saddler's Seam (Hand Seam)« | Seam: matching stitching | Thickness of strap: approx. 5.5 mm to 3.0 mm



276 05
mahagani
mahogany

276 06
cognac
cognac

276 07
mokka
mocha

276 12
ozeanblau
ocean blue

276 13
schwarz
black



Länge Length (mm)		M	
		114	82
Breite Width			
Anstoß / Lug	Schließe / Buckle		
18 mm	16 mm	●	
19 mm	16 mm	●	
20 mm	16 mm	●	
20 mm	18 mm	●	

Form Querschnitt | Cross-section:



Mod. **273** Premier

DE: *Echt Alligatorenleder in glanz, Fullcut* | »Art Manuel« | »Handnaht« |
 Naht: *Ton in Ton* | Bandstärke: *ca. 3,0 mm auf 2,5 mm*

ENG: *Genuine Alligator Leather, glossy finish, fullcut* | »Art Manuel« | »Saddler's Seam (Hand Seam)« |
 Seam: *matching stitching* | Thickness of strap: *approx. 3.0 mm to 2.5 mm*



273 **05**
mahagoni
mahogany

273 **07**
mokka
mocha

273 **12**
ozeanblau
ocean blue

273 **13**
schwarz
black



Länge Length (mm)		M	
		114	82
Breite Width			
Anstoß / Lug	Schließe / Buckle		
18 mm	16 mm	●	
19 mm	16 mm	●	
20 mm	16 mm	●	
20 mm	18 mm	●	
21 mm	18 mm	▲	

Form Querschnitt | Cross-section:



Mod. **272** Senator

DE: *Echt Alligatorenleder in matt, Fullcut* | »Art Manuel« | »Handnaht« |
 Naht: *Ton in Ton* | Bandstärke: *ca. 3,0 mm auf 2,5 mm*

ENG: *Genuine Alligator Leather, matt finish, fullcut* | »Art Manuel« | »Saddler's Seam (Hand Seam)« |
 Seam: *matching stitching* | Thickness of strap: *approx. 3.0 mm to 2.5 mm*



272 **05**
mahagoni
mahogany

272 **06**
cognac
cognac

272 **07**
mokka
mocha

272 **12**
ozeanblau
ocean blue

272 **13**
schwarz
black



Länge Length (mm)		M	
		114	82
Breite Width			
Anstoß / Lug	Schließe / Buckle		
18 mm	16 mm	●	
19 mm	16 mm	●	
20 mm	16 mm	●	
21 mm	18 mm	▲	
22 mm	18 mm	▲	

Form Querschnitt | Cross-section:



Mod. 270 | Imperator

DE: *Echt Alligatorenleder in matt, Fullcut | »Art Manuel« | »Handnaht« | Naht: Ton in Ton | Bandstärke: ca. 5,0mm auf 3,0mm*

ENG: *Genuine Alligator Leather, matt finish, fullcut | »Art Manuel« | »Saddler's Seam (Hand Seam)« | Seam: matching stitching | Thickness of strap: approx. 5.0mm to 3.0mm*



- 270 **05**
mahagoni
mahogany
- 270 **06**
cognac
cognac
- 270 **07**
mokka
mocha
- 270 **12**
ozeanblau
ocean blue
- 270 **13**
schwarz
black



Länge Length (mm)		M	
		114	82
Breite Width			
Anstoß / Lug	Schließe / Buckle		
18 mm	16 mm	●	
19 mm	16 mm	●	
20 mm	18 mm	●	
22 mm	18 mm	▲	

Form Querschnitt | Cross-section:



Mod. 266 | Monarch

DE: *Echt Alligatorenleder in matt, Fullcut | Mit Alligatorenfutter | »Art Manuel« | »Handnaht« | Naht: Ton in Ton | Bandstärke: ca. 5,5mm auf 3,0mm*

ENG: *Genuine Alligator Leather, matt finish, fullcut | With alligator lining | »Art Manuel« | »Saddler's Seam (Hand Seam)« | Seam: matching stitching | Thickness of strap: approx. 5.5mm to 3.0mm*



- 266 **05**
mahagoni
mahogany
- 266 **06**
cognac
cognac
- 266 **07**
mokka
mocha
- 266 **13**
schwarz
black
- 266 **05**
Rückseite
Reverse side
- 266 **06**
Rückseite
Reverse side
- 266 **07**
Rückseite
Reverse side
- 266 **13**
Rückseite
Reverse side



Länge Length (mm)		M	
		114	82
Breite Width			
Anstoß / Lug	Schließe / Buckle		
18 mm	16 mm	●	
19 mm	16 mm	●	
20 mm	18 mm	●	
22 mm	18 mm	▲	

Form Querschnitt | Cross-section:



»RUND« | »ROUND«

Mod. **256** **Connoisseur**

DE: *Echt Alligatorenleder in matt, Fullcut | Futter mit Kautschukgriff | »Art Manuel« | »Handnaht« | Naht: Cremeweiß | Bandstärke: ca. 5,5 mm auf 3,0 mm*

ENG: *Genuine Alligator Leather, matt finish, fullcut | Lining with rubber grip | »Art Manuel« | »Saddler's Seam (Hand Seam)« | Seam: cream white | Thickness of strap: approx. 5.5 mm to 3.0 mm*



256 **05**
mahagoni
mahogany



256 **06**
cognac
cognac



256 **07**
mokka
mocha



256 **12**
ozeanblau
ocean blue



256 **13**
schwarz
black



256
Rückseiten
Reverse sides



Länge Length (mm)		M	
		114	82
Breite Width			
Anstoß / Lug	Schließe / Buckle		
18 mm	16 mm	●	
19 mm	16 mm	●	
20 mm	18 mm	●	
22 mm	20 mm	▲	

Form Querschnitt | Cross-section:



»RUND« | »ROUND«

Mod. **252** **Superior**

DE: *Echt Alligatorenleder in matt, Flank | »Art Manuel« | Naht: Ton in Ton | Bandstärke: ca. 7,0 mm auf 3,0 mm*

ENG: *Genuine Alligator Leather, matt finish, flank | »Art Manuel« | Seam: matching stitching | Thickness of strap: approx. 7.0 mm auf 3.0 mm*



252 **05**
mahagoni
mahogany



252 **06**
cognac
cognac



252 **07**
mokka
mocha



252 **12**
ozeanblau
ocean blue



252 **13**
schwarz
black



Länge Length (mm)		M	
		114	82
Breite Width			
Anstoß / Lug	Schließe / Buckle		
18 mm	16 mm	●	
19 mm	16 mm	●	
20 mm	18 mm	●	
22 mm	20 mm	▲	

Form Querschnitt | Cross-section:



»RUND« | »ROUND«

Mod. 250 | Ambassador

DE: *Echt Alligatorenleder in matt, Flank | »Art Manuel« | Naht: Cremeweiß | Bandstärke: ca. 7,0 mm auf 3,0 mm*

ENG: *Genuine Alligator Leather, matt finish, flank | »Art Manuel« | Seam: cream white | Thickness of strap: approx. 7.0 mm to 3.0 mm*



250 **05**
mahagoni
mahogany

250 **06**
cognac
cognac

250 **07**
mokka
mocha

250 **12**
ozeanblau
ocean blue

250 **13**
schwarz
black



Länge Length (mm)		M	
		114	82
Breite Width			
Anstoß / Lug	Schließe / Buckle		
18 mm	16 mm	●	
19 mm	16 mm	●	
20 mm	18 mm	●	
22 mm	18 mm	▲	

Form Querschnitt | Cross-section:



»RUND« | »ROUND«

Mod. 249 | Heritage

DE: *Echt Alligatorenleder in glanz, Flank | »Art Manuel« | Naht: Ton in Ton | Bandstärke: ca. 5,5 mm auf 3,0 mm*

ENG: *Genuine Alligator Leather, glossy finish, flank | »Art Manuel« | Seam: matching stitching | Thickness of strap: approx. 5.5 mm to 3.0 mm*



249 **05**
mahagoni
mahogany

249 **07**
mokka
mocha

249 **12**
ozeanblau
ocean blue

249 **13**
schwarz
black



Mod. **248** | **Imperial**

DE: *Echt Alligatorenleder in matt, Flank* | »Art Manuel« |
 Naht: *Ton in Ton* | Bandstärke: *ca. 5,5 mm auf 3,0 mm*

ENG: *Genuine Alligator Leather, matt finish, flank* | »Art Manuel« |
 Seam: *matching stitching* | Thickness of strap: *approx. 5.5 mm to 3.0 mm*



- 248 **05** mahagoni mahogany
- 248 **06** cognac cognac
- 248 **07** mokka mocha
- 248 **12** ozeanblau ocean blue
- 248 **13** schwarz black

Länge Length (mm)		M	
		114	82
Breite Width			
Anstoß / Lug	Schließe / Buckle		
18 mm	16 mm	●	
19 mm	16 mm	●	
20 mm	18 mm	●	
22 mm	18 mm	▲	

Form Querschnitt | Cross-section:



»RUND« | »ROUND«



Mod. **245** | **Brilliant**

DE: *Echt Alligatorenleder in glanz, Flank* | »Art Manuel« |
 Naht: *Ton in Ton* | Bandstärke: *ca. 3,0 mm auf 2,5 mm*

ENG: *Genuine Alligator Leather, glossy finish, flank* | »Art Manuel« |
 Seam: *matching stitching* | Thickness of strap: *approx. 3.0 mm to 2.5 mm*



- 245 **05** mahagoni mahogany
- 245 **07** mokka mocha
- 245 **12** ozeanblau ocean blue
- 245 **13** schwarz black

Länge Length (mm)		M	
		114	82
Breite Width			
Anstoß / Lug	Schließe / Buckle		
18 mm	16 mm	●	
19 mm	16 mm	●	
20 mm	18 mm	●	

Form Querschnitt | Cross-section:



»ECKIG« | »SQUARE«



Mod. 244 | Prestige

DE: *Echt Alligatorenleder in matt, Flank | »Art Manuel« | Naht: Ton in Ton | Bandstärke: ca. 3,0mm auf 2,5mm*
 ENG: *Genuine Alligator Leather, matt finish, flank | »Art Manuel« | Seam: matching stitching. | Thickness of strap: approx. 3.0mm to 2.5mm*



- 244 05** mahagani mahogany
- 244 06** cognac cognac
- 244 07** mokka mocha
- 244 12** ozeanblau ocean blue
- 244 13** schwarz black

Länge Length (mm)		M	
		114	82
Breite Width			
Anstoß / Lug	Schließe / Buckle		
18 mm	16 mm	●	
19 mm	16 mm	●	
20 mm	18 mm	●	

Form Querschnitt | Cross-section:



Mit Kantenlack
With Edge Colour



Mod. 241 | Royal

DE: *Echt Alligatorenleder in matt, Flank | »Handnaht« | Naht: Cremeweiß | Bandstärke: ca. 2,7mm auf 2,7mm*
 ENG: *Genuine Alligator Leather, matt finish, flank | »Saddler's Seam (Hand Seam)« | Seam: cream white | Thickness of strap: approx. 2.7mm to 2.7mm*



- 241 05** mahagani mahogany
- 241 06** cognac cognac
- 241 07** mokka mocha
- 241 13** schwarz black

Länge Length (mm)		M	
		114	82
Breite Width			
Anstoß / Lug	Schließe / Buckle		
18 mm	16 mm	●	
19 mm	16 mm	●	
20 mm	16 mm	●	
22 mm	18 mm	▲	

Form Querschnitt | Cross-section:



RIOS1931 Handnaht
Von innen vernäht!

RIOS1931 Saddler's Seam
Sewed from inside!



Länge Length (mm)		S	M	XL
		104 72	114 82	124 92
Breite Width				
Anstoß / Lug	Schließe / Buckle			
12 mm	10 mm	●		
14 mm	12 mm	●		
16 mm	14 mm		●	■
18 mm	16 mm		●	■
20 mm	18 mm		●	■

Form Querschnitt | Cross-section:



»ECKIG« | »SQUARE«

Mod. 240 | Lord

DE: Echt Krokodilleder in glanz | »Art Manuel« |

Naht: Ton in Ton | Bandstärke: ca. 3,5 mm auf 3,0 mm

ENG: Genuine Crocodile Leather, glossy finish | »Art Manuel« |

Seam: matching stitching | Thickness of strap: approx. 3.5 mm to 3.0 mm



240 04
honig
honey

240 06
cognac
cognac

240 07
mokka
mocha

240 08
rot
red

240 10
forstgrün
forest green

240 11
bordeaux
burgundy

240 12
ozeanblau
ocean blue

240 13
schwarz
black

240 23
royalblau
royal blue



Länge Length (mm)		M	
		114	82
Breite Width			
Anstoß / Lug	Schließe / Buckle		
16 mm	14 mm		●
18 mm	16 mm		●
19 mm	16 mm		●
20 mm	18 mm		●

Form Querschnitt | Cross-section:



»ECKIG« | »SQUARE«

Mod. 230 | Maison

DE: Echt Straußenleder | »Art Manuel« |

Naht: Ton in Ton | Bandstärke: ca. 3,5 mm auf 3,0 mm

ENG: Genuine Ostrich Leather | »Art Manuel« |

Seam: matching stitching | Thickness of strap: approx. 3.5 mm to 3.0 mm



230 05
mahagoni
mahogany

230 06
cognac
cognac

230 07
mokka
mocha

230 10
forstgrün
forest green

230 13
schwarz
black

230 20
marineblau
navy



Länge Length (mm)		S		M	
		104	72	114	82
Breite Width					
Anstoß / Lug	Schließe / Buckle				
12 mm	10 mm	●			
14 mm	12 mm	●			
16 mm	14 mm			●	
18 mm	16 mm			●	
20 mm	18 mm			●	

Form Querschnitt | Cross-section:



Mod. 222 | **Avenue**

DE: *Echt Teju-Eidechsenleder in glanz* | »Art Manuel« |
 Naht: *Ton in Ton* | Bandstärke: *ca. 3,5 mm auf 3,0 mm*

ENG: *Genuine Teju Lizard Leather, glossy finish* | »Art Manuel« |
 Seam: *matching stitching* | Thickness of strap: *approx. 3.5 mm to 3.0 mm*



- 222 03
steingrau
stone grey
- 222 05
mahagoni
mahogany
- 222 06
cognac
cognac
- 222 07
mokka
mocha
- 222 08
rot
red
- 222 10
forstgrün
forest green
- 222 11
bordeaux
burgundy
- 222 12
ozeanblau
ocean blue
- 222 13
schwarz
black



Länge Length (mm)		S		M	
		104	72	114	82
Breite Width					
Anstoß / Lug	Schließe / Buckle				
12 mm	10 mm	●			
14 mm	12 mm	●			
16 mm	14 mm			●	
18 mm	16 mm			●	
20 mm	18 mm			●	

Form Querschnitt | Cross-section:



Mod. 220 | **Allure**

DE: *Echt Eidechsenleder in glanz* | »Art Manuel« |
 Naht: *Ton in Ton* | Bandstärke: *ca. 2,5 mm auf 2,5 mm*

ENG: *Genuine Lizard Leather, glossy finish* | »Art Manuel« |
 Seam: *matching stitching* | Thickness of strap: *approx. 2.5 mm to 2.5 mm*



- 220 05
mahagoni
mahogany
- 220 06
cognac
cognac
- 220 07
mokka
mocha
- 220 13
schwarz
black



Länge Length (mm)		S	M
		104 72	114 82
Breite Width	Anstoß / Lug		
	Schließe / Buckle		
12mm	10mm	●	
14mm	12mm	●	
15mm	14mm	●	
16mm	14mm		●
17mm	16mm		●
18mm	16mm		●
19mm	16mm		●
20mm	16mm		●

Form Querschnitt | Cross-section:



»LEICHT RUND« | »LIGHT ROUND«

Mod. 218 | **Charme**

DE: *Echt Eidechsenleder in glanz* |
 Naht: *Ohne* | *Bandstärke: ca. 2,0mm auf 2,0mm*
 ENG: *Genuine Lizard Leather, glossy finish* |
 Seam: *no stitching* | *Thickness of strap: approx. 2.0mm to 2.0mm*



- 218 **02**
sand
sand
- 218 **05**
mahagoni
mahogany
- 218 **06**
cognac
cognac
- 218 **07**
mokka
mocha
- 218 **08**
rot
red
- 218 **12**
ozeanblau
ocean blue
- 218 **13**
schwarz
black
- 218 **23**
royalblau
royal blue
- 218 **26**
taupe
taupe



Länge Length (mm)		M
		114 82
Breite Width	Anstoß / Lug	
	Schließe / Buckle	
18mm	16mm	●
20mm	18mm	●
22mm	18mm	▲

Form Querschnitt | Cross-section:



»RUND« | »ROUND«

Mod. 210 | **Wave**

DE: *Echt Haifischleder* | »Art Manuel« | »Wasserresistent« |
 Naht: *Cremeweiß* | *Bandstärke: ca. 6,0mm auf 3,0mm*
 ENG: *Genuine Shark Leather* | »Art Manuel« | »Water resistant« |
 Seam: *cream white* | *Thickness of strap: approx. 6.0mm to 3.0mm*



- 210 **03**
steingrau
stone grey
- 210 **08**
rot
red
- 210 **10**
forstgrün
forest green
- 210 **11**
bordeaux
burgundy
- 210 **12**
ozeanblau
ocean blue
- 210 **13**
schwarz
black
- 210 **18**
apfelgrün
apple green
- 210 **23**
royalblau
royal blue



210
Rückseiten
Reverse sides



20

RIO1931 art manuel
Gottlieb / 1861 SÖNNE

Handgemacht
in Deutschland

RIO1931 art manuel
Gottlieb / 1861 SÖNNE



NEW!



**Biozertifizierte
Uhrenarmbänder
Certified organic
watch straps**

Bio Organic



NEW!

Biozertifizierte
Uhrenarmbänder
Certified organic
watch straps

Leder neu erleben

Unsere neueste Kollektion – die zertifizierten RIOS1931 Bio-Uhrenarmbänder – ist sicher die außergewöhnlichste Serie in unserem Sortiment.

Erleben Sie das einzigartige Gefühl eines naturbelassenen RIOS1931 Bio-Uhrenarmbands auf Ihrer Haut!

Re-experience leather

Our latest collection – the certified RIOS1931 Organic watch straps – the most extraordinary series in our range.

Experience the unique feeling of a natural RIOS1931 Organic watch strap on your skin!



RIOS1931 Bio-Uhrenarmbänder

RIOS1931 Organic watch straps

Garantiert 100% Bio

Sämtliche Schritte innerhalb der Produktionskette sind ökologisch nachhaltig und biozertifiziert.

Die natürlich und pflanzlich gegerbten, absolut weichen Leder verleihen den Bändern dieser Serie eine exzellente Haptik und hohen Tragekomfort.

Frei von Chrom sind unsere Bio-Uhrenarmbänder besonders umweltschonend, gesundheitsverträglich und allergikerfreundlich.

Mit dieser Bio-Uhrenbandkollektion haben wir einen wertvollen Beitrag zur Förderung einer nachhaltigen Wirtschaftsweise geleistet und eine neue Generation von Uhrenarmbändern in unser Sortiment aufgenommen.

Guaranteed 100% organic

All the stages in the production chain are environmentally sustainable and organic certified.

The natural and vegetable-tanned, absolutely soft leather give the straps of this series an excellent feel and high wearing comfort.

Free of chromium, our organic watch straps are environmentally-friendly, health-friendly and allergy-friendly.

With this organic watch strap collection, we have made a valuable contribution to promoting a sustainable economy and introduced a new generation of watch straps to our range.



Biozertifizierte RIOS1931 Uhrenarmbänder

- Chromfrei –
- Allergikerfreundlich –
- Pflanzliche Gerbung –
- Naturbelassene Oberfläche –
- Artgerechte Tierhaltung –
- Geschlossene Nachhaltigkeitskette –
- Leder von deutschen Rindern aus anerkannten Biobetrieben –
- Durch »Lacon« auf die Einhaltung der Biokreis-Richtlinien kontrolliert –
- Leder ist »Biokreis«, ECARF + IVN zertifiziert –



Certified organic RIOS1931 watch straps

- Chromium-free –
- Allergy-friendly –
- Vegetable tanning –
- Natural surface –
- Animal welfare approved –
- Sustainable supply chain –
- Leather from approved organic German cattle farms –
- Verification of compliancy with Biokreis guidelines by »Lacon« –
- Leather is »Biokreis«, ECARF + IVN certified –

Biozertifizierte Produktionskette

Organically certified production chain

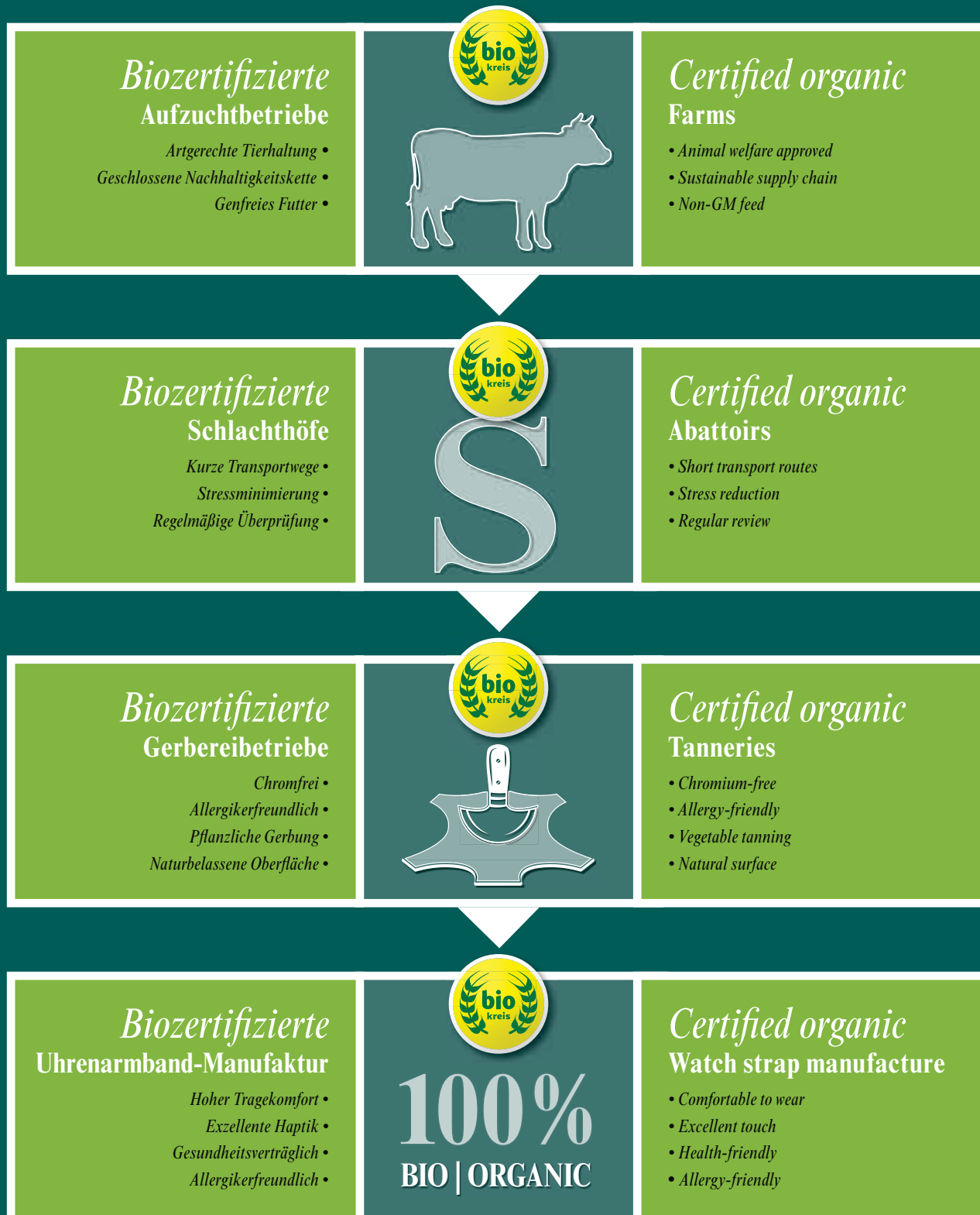

RIOS1931
RIEMER OSWALD

Bio Organic

*Seite | Page 68
Mod. 404*

*Seite | Page 68
Mod. 405*



– Lieferung OHNE Schließe –
Bitte wählen Sie auf den
Seiten 182 / 183



– Supplied WITHOUT clasp –
Please select a clasp on
pages 182 / 183



Mod. 433 | Starnberg

DE: *Echt zertifiziertes Bioleder | »Handnaht« |
Naht: Cremeweiß | Bandstärke: ca. 4,0mm auf 4,0mm*

ENG: *Genuine Certified Organic Leather | »Saddler's Seam (Hand Seam)« |
Seam: cream white | Thickness of strap: approx. 4.0mm to 4.0mm*



433 06
cognac
cognac



433 07
mokka
mocha



433 13
schwarz
black

Länge Length (mm)		M	
		114	82
Breite Width			
Anstoß / Lug	Schließe / Buckle		
20mm	18mm	●	
22mm	22mm	▲	
24mm	22mm	◐	
24mm	24mm	◑	

Form Querschnitt | Cross-section:

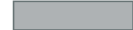

»BLOCK« | »BLOCK«



– Lieferung OHNE Schließe –
Bitte wählen Sie auf den
Seiten 182 / 183



– Supplied WITHOUT clasp –
Please select a clasp on
pages 182 / 183



Mod. 432 | Tegernsee

DE: *Echt zertifiziertes Bioleder | »Handnaht« |
Naht: Ton in Ton | Bandstärke: ca. 4,0mm auf 4,0mm*

ENG: *Genuine Certified Organic Leather | »Saddler's Seam (Hand Seam)« |
Seam: matching stitching | Thickness of strap: approx. 4.0mm to 4.0mm*



432 06
cognac
cognac



432 07
mokka
mocha



432 13
schwarz
black

Länge Length (mm)		M	
		114	82
Breite Width			
Anstoß / Lug	Schließe / Buckle		
20mm	18mm	●	
22mm	22mm	▲	
24mm	22mm	◐	
24mm	24mm	◑	

Form Querschnitt | Cross-section:



»BLOCK« | »BLOCK«





Länge Length (mm)		M	
		114	82
Breite Width			
Anstoß / Lug	Schleife / Buckle		
18 mm	16 mm	●	
19 mm	16 mm	●	
20 mm	18 mm	●	
22 mm	18 mm	▲	

Form Querschnitt | Cross-section:



»RUND« | »ROUND«

Mod. 429 | **Weilheim**

DE: *Echt zertifiziertes Bioleder | »Art Manuel« | »Handnaht« | Naht: Cremeweiß | Bandstärke: ca. 6,0mm auf 3,0mm*

ENG: *Genuine Certified Organic Leather | »Art Manuel« | »Saddler's Seam (Hand Seam)« | Seam: cream white | Thickness of strap: approx. 6.0mm to 3.0mm*



429 **06**
cognac
cognac



429 **07**
mokka
mocha



429 **13**
schwarz
black



Länge Length (mm)		M	
		114	82
Breite Width			
Anstoß / Lug	Schleife / Buckle		
18 mm	16 mm	●	
19 mm	16 mm	●	
20 mm	18 mm	●	
22 mm	18 mm	▲	

Form Querschnitt | Cross-section:



»RUND« | »ROUND«

Mod. 428 | **Garmisch**

DE: *Echt zertifiziertes Bioleder | »Art Manuel« | »Handnaht« | Naht: Ton in Ton | Bandstärke: ca. 6,0mm auf 3,0mm*

ENG: *Genuine Certified Organic Leather | »Art Manuel« | »Saddler's Seam (Hand Seam)« | Seam: matching stitching | Thickness of strap: approx. 6.0mm to 3.0mm*



428 **06**
cognac
cognac



428 **07**
mokka
mocha



428 **13**
schwarz
black





Länge Length (mm)		M	
		118	82
Breite Width			
Anstoß / Lug	Schließe / Buckle		
20 mm	18 mm	●	
22 mm	18 mm	▲	

Form Querschnitt | Cross-section:



»BLOCK« | »BLOCK«

Mod. 427 | **Sonthofen**

DE: *Echt zertifiziertes Bioleder | »Handnaht« | Naht: Cremeweiß | Bandstärke: ca. 3,5 mm auf 3,5 mm*

ENG: *Genuine Certified Organic Leather | »Saddler's Seam (Hand Seam)« | Seam: cream white | Thickness of strap: approx. 3.5 mm to 3.5 mm*



427 06
cognac
cognac



427 07
mokka
mocha



427 13
schwarz
black



Länge Length (mm)		M	
		118	82
Breite Width			
Anstoß / Lug	Schließe / Buckle		
20 mm	18 mm	●	
22 mm	18 mm	▲	

Form Querschnitt | Cross-section:



»BLOCK« | »BLOCK«

Mod. 423 | **Landsberg**

DE: *Echt zertifiziertes Bioleder | »Handnaht« | Naht: Ton in Ton | Bandstärke: ca. 3,5 mm auf 3,5 mm*

ENG: *Genuine Certified Organic Leather | »Saddler's Seam (Hand Seam)« | Seam: matching stitching | Thickness of strap: approx. 3.5 mm to 3.5 mm*



423 06
cognac
cognac



423 07
mokka
mocha



423 13
schwarz
black





Mod. **420** Schongau

DE: *Echt zertifiziertes Bioleder* | »Handnaht« |

Naht: *Ton in Ton* | Bandstärke: *ca. 5,0mm auf 3,0mm*

ENG: *Genuine Certified Organic Leather* | »Saddler's Seam (Hand Seam)« |

Seam: *matching stitching* | Thickness of strap: *approx. 5.0mm to 3.0mm*



420 **06**
cognac
cognac



420 **07**
mokka
mocha



420 **13**
schwarz
black

Länge Length (mm)		M	
		114	82
Breite Width			
Anstoß / Lug	Schleife / Buckle		
18 mm	16 mm	●	
19 mm	16 mm	●	
20 mm	18 mm	●	
22 mm	18 mm	▲	

Form Querschnitt | Cross-section:



»ECKIG« | »SQUARE«



Mod. **416** Füssen

DE: *Echt zertifiziertes Bioleder* | »Handnaht« |

Naht: *Ton in Ton* | Bandstärke: *ca. 3,5mm auf 3,0mm*

ENG: *Genuine Certified Organic Leather* | »Saddler's Seam (Hand Seam)« |

Seam: *matching stitching* | Thickness of strap: *approx. 3.5mm to 3.0mm*



416 **06**
cognac
cognac



416 **07**
mokka
mocha



416 **13**
schwarz
black

Länge Length (mm)		M	
		114	82
Breite Width			
Anstoß / Lug	Schleife / Buckle		
18 mm	16 mm	●	
19 mm	16 mm	●	
20 mm	18 mm	●	

Form Querschnitt | Cross-section:



»ECKIG« | »SQUARE«





Mod. 412 | Peiting

DE: *Echt zertifiziertes Bioleder* | »Handnaht« |
 Naht: *Ton in Ton* | *Bandstärke: ca. 2,5 mm auf 2,5 mm*

ENG: *Genuine Certified Organic Leather* | »Saddler's Seam (Hand Seam)« |
 Seam: *matching stitching* | *Thickness of strap: approx. 2.5 mm to 2.5 mm*



412 06
cognac
cognac

412 07
mokka
mocha

412 13
schwarz
black

Länge Length (mm)		M	
		114	82
Breite Width			
Anstoß / Lug	Schließe / Buckle		
18 mm	16 mm	●	
19 mm	16 mm	●	
20 mm	16 mm	●	
20 mm	18 mm	●	

Form Querschnitt | Cross-section:



»BLOCK« | »BLOCK«



Mod. 408 | Waging

DE: *Echt zertifiziertes Bioleder* |
 Naht: *Ton in Ton* | *Bandstärke: ca. 3,5 mm auf 3,5 mm*

ENG: *Genuine Certified Organic Leather* |
 Seam: *matching stitching* | *Thickness of strap: approx. 3.5 mm to 3.5 mm*



408 06
cognac
cognac

408 07
mokka
mocha

408 13
schwarz
black

Länge Length (mm)		S		M		XL	
		104	72	114	82	124	92
Breite Width							
Anstoß / Lug	Schließe / Buckle						
14 mm	12 mm	●					
16 mm	14 mm	●		●		■	
18 mm	16 mm	●		●		■	
20 mm	18 mm	●		●		■	

Form Querschnitt | Cross-section:



»ECKIG« | »SQUARE«





Länge Length (mm)		M	
		114	82
Breite Width			
Anstoß / Lug	Schleife / Buckle		
18 mm	16 mm	●	
19 mm	16 mm	●	
20 mm	16 mm	●	
22 mm	18 mm	▲	

Form Querschnitt | Cross-section:



»BLOCK« | »BLOCK«

RIOS1931 Handnaht

Von innen vernäht!

RIOS1931 Saddler's Seam

Sewed from inside!

Mod. 405 | Inzell

DE: Echt zertifiziertes Bioleder | »Handnaht« | Naht: Cremeweiß | Bandstärke: ca. 2,7 mm auf 2,7 mm

ENG: Genuine Certified Organic Leather | »Saddler's Seam (Hand Seam)« | Seam: cream white | Thickness of strap: approx. 2.7 mm to 2.7 mm



405 06 cognac
405 07 mokka
405 13 schwarz



405 06 Rückseite
405 07 Rückseite
405 13 Rückseite



Länge Length (mm)		M	
		114	82
Breite Width			
Anstoß / Lug	Schleife / Buckle		
18 mm	16 mm	●	
19 mm	16 mm	●	
20 mm	16 mm	●	
22 mm	18 mm	▲	

Form Querschnitt | Cross-section:



»BLOCK« | »BLOCK«

RIOS1931 Handnaht

Von innen vernäht!

RIOS1931 Saddler's Seam

Sewed from inside!

Mod. 404 | Mittenwald

DE: Echt zertifiziertes Bioleder | »Handnaht« | Naht: Ton in Ton | Bandstärke: ca. 2,7 mm auf 2,7 mm

ENG: Genuine Certified Organic Leather | »Saddler's Seam (Hand Seam)« | Seam: matching stitching | Thickness of strap: approx. 2.7 mm to 2.7 mm



404 06 cognac
404 07 mokka
404 13 schwarz



404 06 Rückseite
404 07 Rückseite
404 13 Rückseite





Länge Length (mm)		M	
		114	82
Breite Width			
Anstoß / Lug	Schließe / Buckle		
16 mm	14 mm	●	
18 mm	16 mm	●	
20 mm	18 mm	●	

Form Querschnitt | Cross-section:



»LEICHT RUND« | »LIGHT ROUND«

Mod. 400 | **Kempton**

DE: *Echt zertifiziertes Bioleder* |

Naht: *Ohne* | Bandstärke: *ca. 2,2 mm auf 2,2 mm*

ENG: *Genuine Certified Organic Leather* |

Seam: *no stitching* | *Thickness of strap: approx. 2.2 mm to 2.2 mm*



400 06
cognac
cognac



400 07
mokka
mocha



400 13
schwarz
black



Seite | Page 68

Mod. 404



*Juchten /
Shell Cordovan
Russia Leather /
Shell Cordovan*

*Seite | Page 71
Mod. 205*



Länge Length (mm)		M	
		114	82
Breite Width			
Anstoß / Lug	Schließe / Buckle		
18 mm	16 mm	●	
19 mm	16 mm	●	
20 mm	18 mm	●	
22 mm	18 mm	▲	

Form Querschnitt | Cross-section:



»RUND« | »ROUND«

Mod. 205 | Kaluga

DE: *Echt Juchtenleder mit Racinglöchern* | »Art Manuel« |
 Naht: *Cremeweiß* | *Bandstärke: ca. 6,0mm auf 3,0mm*

ENG: *Genuine Russia Leather with racing holes* | »Art Manuel« |
 Seam: *cream white* | *Thickness of strap: approx. 6.0mm to 3.0mm*



- 205 **02**
sand
sand
- 205 **03**
steingrau
stone grey
- 205 **04**
honig
honey
- 205 **06**
cognac
cognac
- 205 **07**
mokka
mocha
- 205 **13**
schwarz
black



Länge Length (mm)		M	
		114	82
Breite Width			
Anstoß / Lug	Schließe / Buckle		
18 mm	16 mm	●	
20 mm	18 mm	●	
22 mm	18 mm	▲	

Form Querschnitt | Cross-section:



»ECKIG« | »SQUARE«

Mod. 204 | Tula

DE: *Echt Juchtenleder mit Uhren-Lederunterlage* | »Art Manuel« |
 Naht: *Ton in Ton* | *Bandstärke: ca. 3,5mm auf 3,0mm*

ENG: *Genuine Russia Leather with watch leather underlay* | »Art Manuel« |
 Seam: *matching stitching* | *Thickness of strap: approx. 3.5mm to 3.0mm*



- 204 **02**
sand
sand
- 204 **03**
steingrau
stone grey
- 204 **04**
honig
honey
- 204 **06**
cognac
cognac
- 204 **07**
mokka
mocha
- 204 **13**
schwarz
black



Länge Length (mm)		M	
		114	82
Breite Width			
Anstoß / Lug	Schließe / Buckle		
18 mm	16 mm	●	
19 mm	16 mm	●	
20 mm	16 mm	●	
20 mm	18 mm	●	

Form Querschnitt | Cross-section:



»ECKIG« | »SQUARE«

Mod. 203 | Pensa

DE: *Echt Juchtenleder* | »Art Manuel« |
 Naht: *Cremeweiß* | *Bandstärke: ca. 3,5 mm auf 3,0 mm*
 ENG: *Genuine Russia Leather* | »Art Manuel« |
 Seam: *cream white* | *Thickness of strap: approx. 3.5 mm to 3.0 mm*

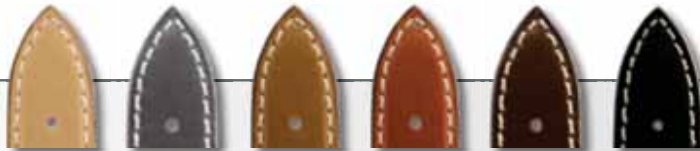

203 **02** sand
 203 **03** steingrau / stone grey
 203 **04** honig / honey
 203 **06** cognac / cognac
 203 **07** mokka / mocha
 203 **13** schwarz / black



Länge Length (mm)		M	
		114	82
Breite Width			
Anstoß / Lug	Schließe / Buckle		
18 mm	16 mm	●	
19 mm	16 mm	●	
20 mm	16 mm	●	
20 mm	18 mm	●	

Form Querschnitt | Cross-section:



»ECKIG« | »SQUARE«

Mod. 202 | Samara

DE: *Echt Juchtenleder* | »Art Manuel« |
 Naht: *Ton in Ton* | *Bandstärke: ca. 3,5 mm auf 3,0 mm*
 ENG: *Genuine Russia Leather* | »Art Manuel« |
 Seam: *matching stitching* | *Thickness of strap: approx. 3.5 mm to 3.0 mm*



202 **02** sand
 202 **03** steingrau / stone grey
 202 **04** honig / honey
 202 **06** cognac / cognac
 202 **07** mokka / mocha
 202 **13** schwarz / black



Länge Length (mm)		M	
		114	82
Breite Width			
Anstoß / Lug	Schließe / Buckle		
18 mm	16 mm	●	
19 mm	16 mm	●	
20 mm	16 mm	●	
20 mm	18 mm	●	
22 mm	18 mm	▲	

Form Querschnitt | Cross-section:



Mod. 201 | St. Petersburg

DE: *Echt Juchtenleder* | »Art Manuel« |
 Naht: *Cremeweiß* | Bandstärke: *ca. 6,0mm auf 3,0mm*
 ENG: *Genuine Russia Leather* | »Art Manuel« |
 Seam: *cream white* | Thickness of strap: *approx. 6.0mm to 3.0mm*



201 **02** sand
 201 **03** steingrau stone grey
 201 **04** honig honey
 201 **06** cognac cognac
 201 **07** mokka mocha
 201 **13** schwarz black



Länge Length (mm)		M	
		114	82
Breite Width			
Anstoß / Lug	Schließe / Buckle		
18 mm	16 mm	●	
19 mm	16 mm	●	
20 mm	16 mm	●	
20 mm	18 mm	●	
22 mm	18 mm	▲	

Form Querschnitt | Cross-section:



Mod. 200 | Moscow

DE: *Echt Juchtenleder* | »Art Manuel« |
 Naht: *Ton in Ton* | Bandstärke: *ca. 6,0mm auf 3,0mm*
 ENG: *Genuine Russia Leather* | »Art Manuel« |
 Seam: *matching stitching* | Thickness of strap: *approx. 6.0mm to 3.0mm*



200 **02** sand
 200 **03** steingrau stone grey
 200 **04** honig honey
 200 **06** cognac cognac
 200 **07** mokka mocha
 200 **13** schwarz black



Länge Length (mm)		M	
		114	82
Breite Width			
Anstoß / Lug	Schließe / Buckle		
18 mm	16 mm	●	
19 mm	16 mm	●	
20 mm	18 mm	●	
22 mm	18 mm	▲	

Form Querschnitt | Cross-section:



Mod. 199 | New York

DE: *Echt Shell Cordovan Leder* | »Art Manuel« | »Handnaht« |
 Naht: *Cremeweiß* | Bandstärke: *ca. 6,0 mm auf 3,0 mm*

ENG: *Genuine Shell Cordovan Leather* | »Art Manuel« | »Saddler's Seam (Hand Seam)« |
 Seam: *cream white* | Thickness of strap: *approx. 6.0 mm to 3.0 mm*



199 **04**
honig
honey

199 **06**
cognac
cognac

199 **07**
mokka
mocha

199 **13**
schwarz
black



Länge Length (mm)		M	
		114	82
Breite Width			
Anstoß / Lug	Schließe / Buckle		
18 mm	16 mm	●	
19 mm	16 mm	●	
20 mm	18 mm	●	
22 mm	18 mm	▲	

Form Querschnitt | Cross-section:



Mod. 198 | Chicago

DE: *Echt Shell Cordovan Leder* | »Art Manuel« | »Handnaht« |
 Naht: *Ton in Ton* | Bandstärke: *ca. 6,0 mm auf 3,0 mm*

ENG: *Genuine Shell Cordovan Leather* | »Art Manuel« | »Saddler's Seam (Hand Seam)« |
 Seam: *matching stitching* | Thickness of strap: *approx. 6.0 mm to 3.0 mm*



198 **04**
honig
honey

198 **06**
cognac
cognac

198 **07**
mokka
mocha

198 **13**
schwarz
black



Mod. 193 Seattle

DE: *Echt Shell Cordovan Leder* | »Art Manuel« |

Naht: *Ton in Ton* | Bandstärke: *ca. 2,5 mm auf 2,5 mm*

ENG: *Genuine Shell Cordovan Leather* | »Art Manuel« |

Seam: *matching stitching* | *Thickness of strap: approx. 2.5 mm to 2.5 mm*

Länge Length (mm)		M	
		114	82
Breite Width			
Anstoß / Lug	Schließe / Buckle		
18 mm	16 mm	●	
20 mm	16 mm	●	
20 mm	18 mm	●	

Form Querschnitt | Cross-section:



»BLOCK« | »BLOCK«



193 04
honig
honey

193 06
cognac
cognac

193 07
mokka
mocha

193 13
schwarz
black

Seite | Page 73
Mod. 200

Seite | Page 71
Mod. 205

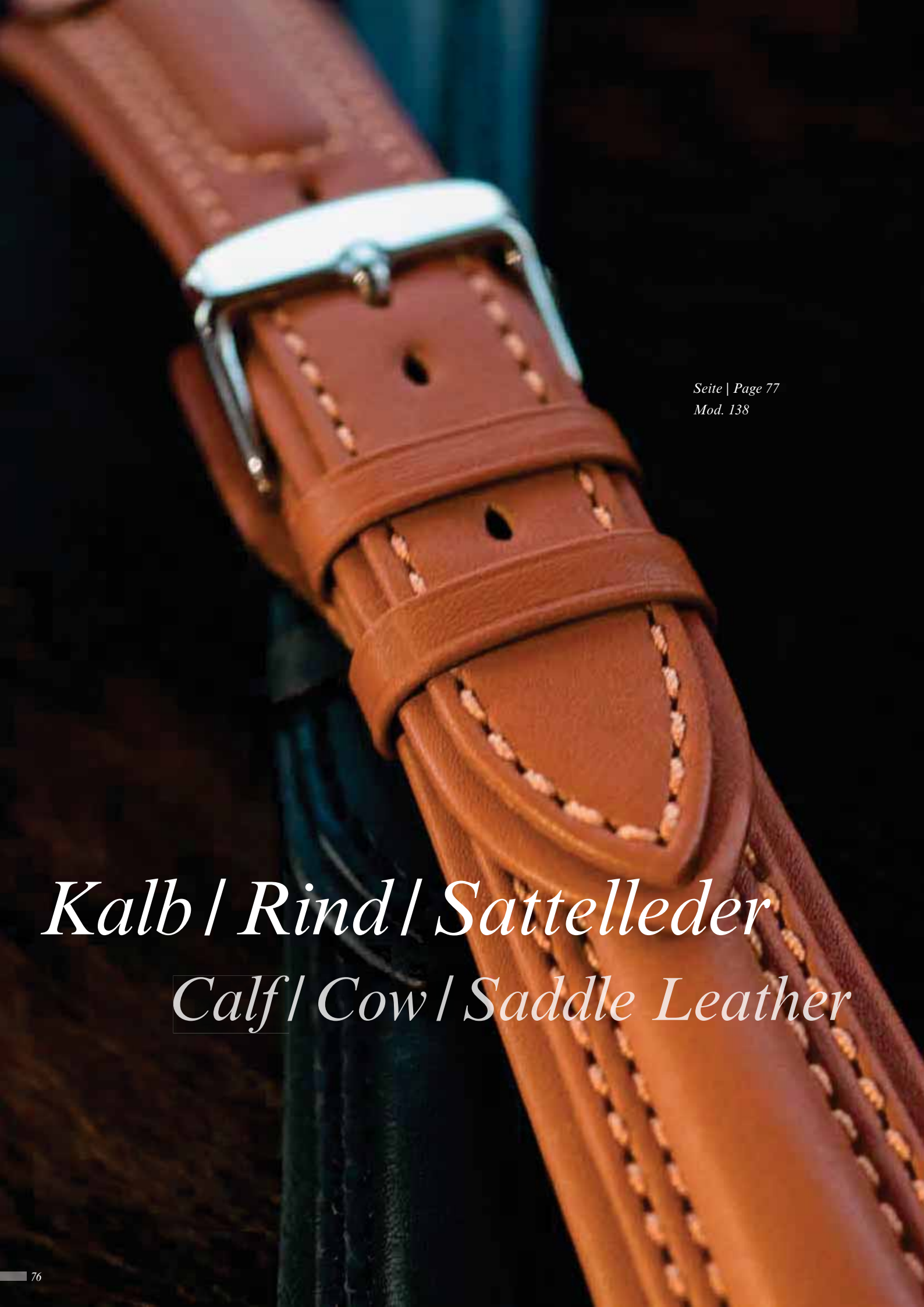
A close-up photograph of a brown leather strap, likely for a watch or bracelet. The strap features a silver-toned metal buckle and decorative stitching along its edges. The leather has a smooth texture and is set against a dark, blurred background.

Seite | Page 77
Mod. 138

Kalb | Rind | Sattelleder
Calf | Cow | Saddle Leather



Länge Length (mm)		M	
		120	92
Breite Width			
Anstoß / Lug	Schließe / Buckle		
20 mm	20 mm	●	
22 mm	20 mm	▲	
24 mm	20 mm	◐	

Form Querschnitt | Cross-section:



Mod. 138 | Apulia

DE: *Echt Kalbsleder* |

Naht: *Ton in Ton* | Bandstärke: *ca. 7,5 mm auf 4,5 mm*

ENG: *Genuine Calfskin* |

Seam: *matching stitching* | Thickness of strap: *approx. 7.5 mm to 4.5 mm*



138 **06**
cognac
cognac



138 **07**
mokka
mocha



138 **13**
schwarz
black



138
Rückseiten
Reverse sides



Länge Length (mm)		M	
		114	82
Breite Width			
Anstoß / Lug	Schließe / Buckle		
18 mm	16 mm	●	
20 mm	18 mm	●	

Form Querschnitt | Cross-section:



Mod. 137 | Veneto

DE: *Echt Kalbsleder* |

Naht: *Ton in Ton* | Bandstärke: *ca. 5,0 mm auf 4,0 mm*

ENG: *Genuine Calfskin* |

Seam: *matching stitching* | Thickness of strap: *approx. 5.0 mm to 4.0 mm*



137 **06**
cognac
cognac



137 **07**
mokka
mocha



137 **12**
ozeanblau
ocean blue



137 **13**
schwarz
black



Länge Length (mm)		M	XL
		114 82	124 92
Breite Width			
Anstoß / Lug	Schließe / Buckle		
18 mm	16 mm	●	■
20 mm	18 mm	●	■
22 mm	20 mm	▲	◆

Form Querschnitt | Cross-section:



»CHRONO« | »CHRONO«

Mod. 135 | **Maranello**

DE: *Echt Kalbsleder* |

Naht: *Cremeweiß* | Bandstärke: *ca. 5,0 mm auf 4,0 mm*

ENG: *Genuine Calfskin* |

Seam: *cream white* | Thickness of strap: *approx. 5.0 mm to 4.0 mm*



135 **06**
cognac
cognac

135 **07**
mokka
mocha

135 **08**
rot
red

135 **10**
forstgrün
forest green

135 **13**
schwarz
black

135 **16**
gelb
yellow

135 **23**
royalblau
royal blue



Länge Length (mm)		M
		114 82
Breite Width		
Anstoß / Lug	Schließe / Buckle	
18 mm	16 mm	●
19 mm	16 mm	●
20 mm	18 mm	●
21 mm	18 mm	▲
22 mm	18 mm	▲

Form Querschnitt | Cross-section:



»ECKIG« | »SQUARE«

Mod. 104 | **Capri**

DE: *Echt Kalbsleder* |

Naht: *Ton in Ton* | Bandstärke: *ca. 5,0 mm auf 3,0 mm*

ENG: *Genuine Calfskin* |

Seam: *matching stitching* | Thickness of strap: *approx. 5.0 mm to 3.0 mm*



104 **05**
mahagoni
mahogany

104 **06**
cognac
cognac

104 **07**
mokka
mocha

104 **11**
bordeaux
burgundy

104 **12**
ozeanblau
ocean blue

104 **13**
schwarz
black

104
Rückseiten
Reverse sides



Länge Length (mm)		S		M	
Breite Width		104	72	114	82
Anstoß / Lug	Schließe / Buckle				
10mm	08mm	●			
12mm	10mm	●			
14mm	12mm	●			
16mm	14mm	●	●		
17mm	16mm			●	
18mm	16mm	●		●	
19mm	16mm			●	
20mm	18mm	●		●	
22mm	20mm			▲	
24mm	22mm			◐	
26mm	24mm			◑	
28mm	26mm			◒	
30mm	28mm			■	

Mod. 102 | Toscana

DE: Echt Kalbsleder |

Naht: Ton in Ton | Bandstärke: ca. 3,5mm auf 3,0mm

ENG: Genuine Calfskin |

Seam: matching stitching | Thickness of strap: approx. 3.5mm to 3.0mm

Form Querschnitt | Cross-section:



»ECKIG« | »SQUARE«



- 102 **02**
sand
sand
- 102 **04**
honig
honey
- 102 **06**
cognac
cognac
- 102 **07**
mokka
mocha
- 102 **08**
rot
red
- 102 **09**
rosa
pale pink
- 102 **10**
forstgrün
forest green
- 102 **11**
bordeaux
burgundy
- 102 **12**
ozeanblau
ocean blue
- 102 **13**
schwarz
black
- 102 **16**
gelb
yellow
- 102 **19**
eisblau
ice blue
- 102 **23**
royalblau
royal blue



Länge Length (mm)		M	
Breite Width		114	82
Anstoß / Lug	Schließe / Buckle		
18mm	16mm		●
20mm	18mm		●

Form Querschnitt | Cross-section:



»RUND« | »ROUND«

Mod. 68 | Nevada

DE: Echt Sattelleder |

Doppelnah: Ton in Ton | Bandstärke: ca. 4,0mm auf 3,5mm

ENG: Genuine Saddle Leather |

Double seam: matching stitching | Thickness of strap: approx. 4.0mm to 3.5mm



- 68 **06**
cognac
cognac
- 68 **07**
mokka
mocha
- 68 **10**
forstgrün
forest green
- 68 **11**
bordeaux
burgundy
- 68 **12**
ozeanblau
ocean blue
- 68 **13**
schwarz
black



Länge Length (mm)		M	
		114	82
Breite Width			
Anstoß / Lug	Schließe / Buckle		
16 mm	14 mm	●	
18 mm	16 mm	●	
20 mm	18 mm	●	

Mod. 54 California Sport

DE: *Echt Sattelleder* |

Naht: *Ton in Ton* | Bandstärke: *ca. 4,0 mm auf 4,0 mm*

ENG: *Genuine Saddle Leather* |

Seam: *matching stitching* | Thickness of strap: *approx. 4.0 mm to 4.0 mm*



54 06
cognac
cognac

54 07
mokka
mocha

54 12
ozeanblau
ocean blue

54 13
schwarz
black



Länge Length (mm)		S	M	XL
		104 72	114 82	116 86
Breite Width				
Anstoß / Lug	Schließe / Buckle			
10 mm	08 mm	●		■
12 mm	10 mm	●		■
14 mm	12 mm	●		■
16 mm	14 mm	●	●	■
18 mm	16 mm	●	●	■
20 mm	18 mm	●	●	■
22 mm	20 mm		▲	◆

XL = 124 / 92

Form Querschnitt | Cross-section:

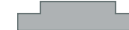

»ECKIG« | »SQUARE«

Mod. 46 Arizona

DE: *Echt Sattelleder* |

Naht: *Ton in Ton* | Bandstärke: *ca. 3,5 mm auf 3,5 mm*

ENG: *Genuine Saddle Leather* |

Seam: *matching stitching* | Thickness of strap: *approx. 3.5 mm to 3.5 mm*

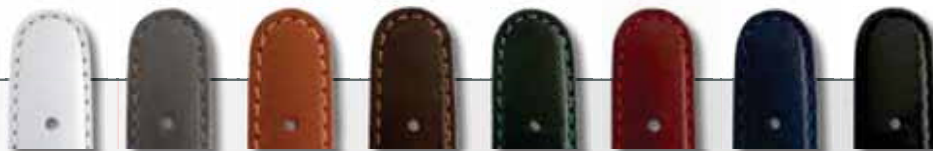

46 01
weiß
white

46 03
steingrau
stone grey

46 06
cognac
cognac

46 07
mokka
mocha

46 10
forstgrün
forest green

46 11
bordeaux
burgundy

46 12
ozeanblau
ocean blue

46 13
schwarz
black



| Spangband | | Clasp strap |

Schnelles und einfaches Wechseln
Der Federsteg muss nicht ausgebaut werden

A fast and easy system to change the clasp
The pin does not have to be removed

Länge Length (mm)	S		M	
	104	72	114	82
Breite Width				
Anstoß / Lug	Schließe / Buckle			
10mm	08mm	●		
12mm	10mm	●		
14mm	12mm	●		
16mm	14mm		●	
18mm	16mm		●	
20mm	18mm		●	

Form Querschnitt | Cross-section:



[Mod. 46S] **Arizona** »mit Spange« | »with clasp«

DE: Echt Sattelleder |
Naht: Ton in Ton | Bandstärke: ca. 3,5mm auf 3,5mm

ENG: Genuine Saddle Leather |
Seam: matching stitching | Thickness of strap: approx. 3.5mm to 3.5mm



[Mod. 45] **French**

DE: Echt Rindsleder |
Naht: Ton in Ton | Bandstärke: ca. 3,0mm auf 2,7mm

ENG: Genuine Cowhide |
Seam: matching stitching | Thickness of strap: approx. 3.0mm to 2.7mm

Länge Length (mm)	S		M		XL
	104	72	114	82	124 92
Breite Width					
Anstoß / Lug	Schließe / Buckle				
14mm	12mm	●			
16mm	14mm	●	●	■	
18mm	16mm	●	●	■	
19mm	16mm		●	■	
20mm	16mm		●	■	
20mm	18mm		●	■	
22mm	18mm		▲	◆	

Form Querschnitt | Cross-section:





Mod. 44 | **Smart**

DE: *Echt Rindsleder* | »Art Manuel« |
 Naht: *Farbig* | *Bandstärke: ca. 6,0mm auf 3,0mm*
 ENG: *Genuine Cowhide* | »Art Manuel« |
 Seam: *coloured* | *Thickness of strap: approx. 6.0mm to 3.0mm*



- 44 **08**
rot
red
- 44 **14**
orange
orange
- 44 **16**
gelb
yellow
- 44 **18**
apfelgrün
apple green
- 44 **23**
royalblau
royal blue

Länge Length (mm)		M	
		114 82	
Breite Width			
Anstoß / Lug	Schließe / Buckle		
18 mm	16 mm	●	
20 mm	18 mm	●	
22 mm	20 mm	▲	

Form Querschnitt | Cross-section:



»RUND« | »ROUND«



Mod. 43 | **Elegant**

DE: *Echt Rindsleder* |
 Naht: *Ohne* | *Bandstärke: ca. 2,0mm auf 2,0mm*
 ENG: *Genuine Cowhide* |
 Seam: *no stitching* | *Thickness of strap: approx. 2.0mm to 2.0mm*



- 43 **01**
weiß
white
- 43 **02**
sand
sand
- 43 **03**
steingrau
stone grey
- 43 **06**
cognac
cognac
- 43 **07**
mokka
mocha
- 43 **08**
rot
red
- 43 **11**
bordeaux
burgundy
- 43 **12**
ozeanblau
ocean blue
- 43 **13**
schwarz
black

Länge Length (mm)		M	
		114 82	
Breite Width			
Anstoß / Lug	Schließe / Buckle		
16 mm	14 mm	●	
18 mm	16 mm	●	
20 mm	18 mm	●	

Form Querschnitt | Cross-section:



»BLOCK« | »BLOCK«



Länge Length (mm)		M	
		114	82
Breite Width			
Anstoß / Lug	Schließe / Buckle		
18 mm	16 mm	●	
20 mm	18 mm	●	
22 mm	20 mm	▲	

Form Querschnitt | Cross-section:



Mod. 41 | **Solid**

DE: *Echt Rindsleder* |

Naht: *Ton in Ton* | *Bandstärke: ca. 5,0mm auf 3,0mm*

ENG: *Genuine Cowhide* |

Seam: *matching stitching* | *Thickness of strap: approx. 5.0mm to 3.0mm*



41 **06**
cognac
cognac



41 **07**
mokka
mocha



41 **13**
schwarz
black



41
Rückseiten
Reverse sides



Länge Length (mm)		S	M	XL
		104 72	114 82	116 86
Breite Width				
Anstoß / Lug	Schließe / Buckle			
08 mm	08 mm	●		■
10 mm	08 mm	●		■
12 mm	10 mm	●		■
14 mm	12 mm	●		■
16 mm	14 mm	●	●	■
17 mm	16 mm		●	
18 mm	16 mm	●	●	■
18 mm	18 mm		●	
19 mm	16 mm		●	
20 mm	18 mm	●	●	■
20 mm	20 mm		●	
22 mm	20 mm		▲	◆

Form Querschnitt | Cross-section:



Mod. 34 | **Classic**

DE: *Echt Rindsleder* |

Naht: *Ohne* | *Bandstärke: ca. 2,5mm auf 2,5mm*

ENG: *Genuine Cowhide* |

Seam: *no stitching* | *Thickness of strap: approx. 2.5mm to 2.5mm*



34 **01**
weiß
white



34 **02**
sand
sand



34 **03**
steingrau
stone grey



34 **06**
cognac
cognac



34 **07**
mokka
mocha



34 **08**
rot
red



34 **11**
bordeaux
burgundy



34 **12**
ozeanblau
ocean blue



34 **13**
schwarz
black



| Spangband | | Clasp strap |

Schnelles und einfaches Wechseln
Der Federsteg muss nicht ausgebaut werden

A fast and easy system to change the clasp
The pin does not have to be removed

Länge Length (mm)		S	M	XL
		104 72	114 82	116 86
Breite Width	Anstoß / Lug			
06 mm	06 mm	●		■
08 mm	08 mm	●		■
10 mm	08 mm	●		■
12 mm	10 mm	●		■
14 mm	12 mm	●		■
16 mm	14 mm	●	●	■
18 mm	16 mm	●	●	■
20 mm	18 mm	●	●	■

XL = 124 / 92

Form Querschnitt | Cross-section:



»LEICHT RUND« | »LIGHT ROUND«

Mod. 30S | Diplomat »mit Spange« | »with clasp«

DE: Echt Rindsleder |

Naht: Ohne | Bandstärke: ca. 2,5 mm auf 2,5 mm

ENG: Genuine Cowhide |

Seam: no stitching | Thickness of strap: approx. 2.5 mm to 2.5 mm



30S 01
weiß
white

30S 02
sand
sand

30S 03
steingrau
stone grey

30S 06
cognac
cognac

30S 07
mokka
mocha

30S 11
bordeaux
burgundy

30S 12
ozeanblau
ocean blue

30S 13
schwarz
black



Länge Length (mm)		M	
		114	82
Breite Width	Anstoß / Lug		
18 mm	16 mm		●
20 mm	18 mm		●

Form Querschnitt | Cross-section:



»SEITENWULST« | »SIDE BULGE«

Mod. 21 | Racing

DE: Echt Rindsleder mit Racinglöchern |

Naht: Ton in Ton | Bandstärke: ca. 3,0 mm auf 3,0 mm

ENG: Genuine Cowhide with racing holes |

Seam: matching stitching | Thickness of strap: approx. 3.0 mm to 3.0 mm



21 06
cognac
cognac

21 07
mokka
mocha

21 13
schwarz
black



Länge Length (mm)		S		M	
		104	72	114	82
Breite Width					
Anstoß / Lug	Schließe / Buckle				
12 mm	10 mm	●			
14 mm	12 mm	●			
16 mm	14 mm			●	
18 mm	16 mm			●	
20 mm	18 mm			●	

Form Querschnitt | Cross-section:



»SEITENWULST« | »SIDE BULGE«

Mod. 20 | **Ecco**

DE: *Echt Rindsleder* |

Naht: *Ton in Ton* | *Bandstärke: ca. 3,0mm auf 3,0mm*

ENG: *Genuine Cowhide* |

Seam: *matching stitching* | *Thickness of strap: approx. 3.0mm to 3.0mm*



20 **06**
cognac
cognac

20 **07**
mokka
mocha

20 **13**
schwarz
black

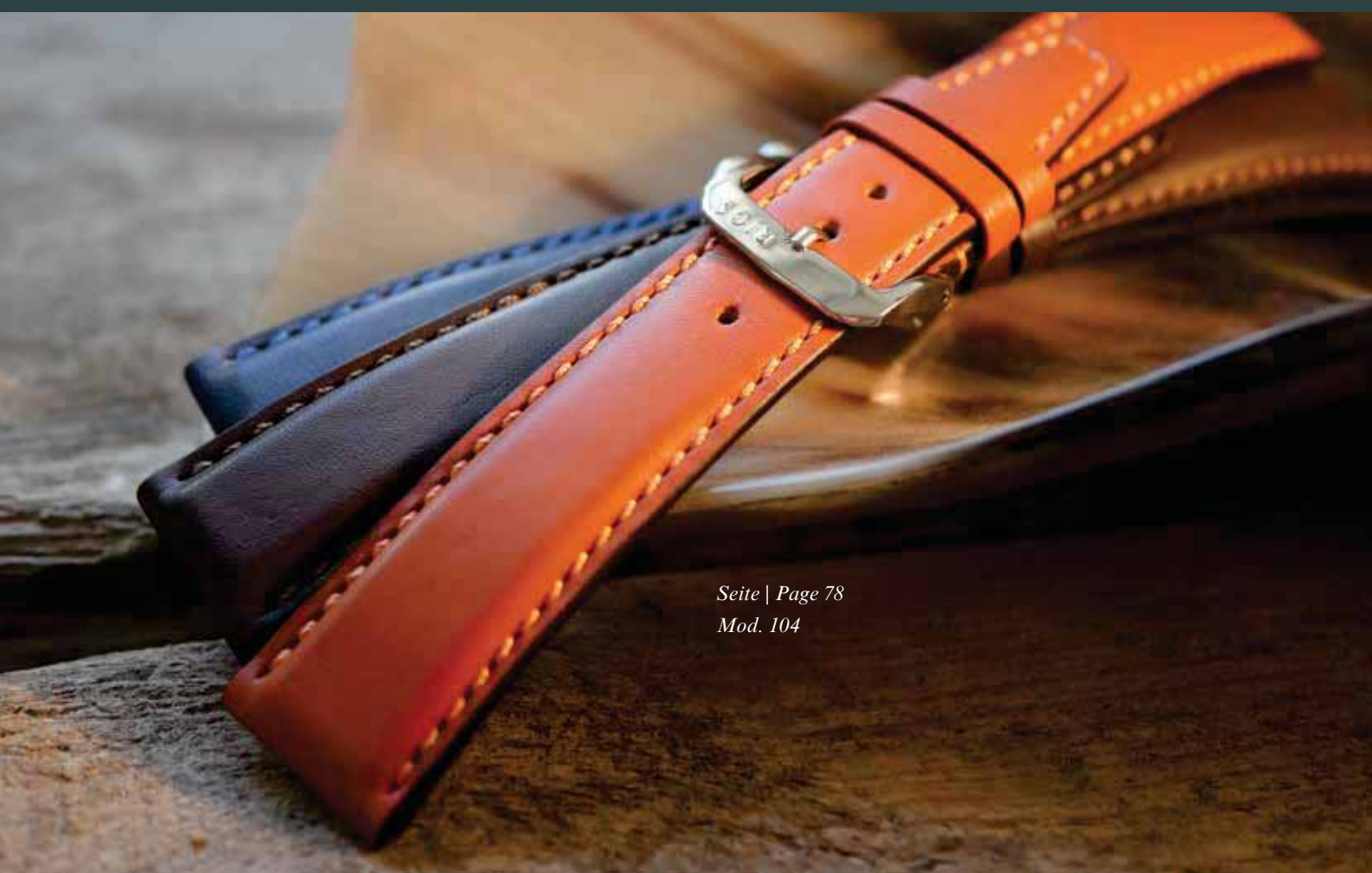

Seite | Page 78

Mod. 104



*Büffel /
Lamm / Schwein*

*Buffalo /
Lamb / Pig*

Seite | Page 91
Mod. 47



Länge Length (mm)		M	
		154	82
Breite Width			
Anstoß / Lug	Schließe / Buckle		
20 mm	18 mm	●	
22 mm	20 mm	▲	

Form Querschnitt | Cross-section:



»BLOCK« | »BLOCK«

Mod. 209 | Aviator

DE: *Echt Büffelleder* |

Naht: *Cremeweiß* | Bandstärke: *ca. 4,0 mm auf 4,0 mm*

ENG: *Genuine Buffalo Leather* |

Seam: *Cream white* | *Thickness of strap: approx. 4.0 mm to 4.0 mm*



209 **06**
cognac
cognac

209 **07**
mokka
mocha

209 **13**
schwarz
black

209 **06**
Rückseite
Reverse side

209 **07**
Rückseite
Reverse side

209 **13**
Rückseite
Reverse side



Länge Length (mm)		M	
		120	92
Breite Width			
Anstoß / Lug	Schließe / Buckle		
20 mm	20 mm	●	
22 mm	20 mm	▲	
24 mm	20 mm	◐	

Form Querschnitt | Cross-section:



»RUND« | »ROUND«

Mod. 207 | Performance

DE: *Echt Büffelleder* |

Naht: *Cremeweiß / Ton in Ton* | Bandstärke: *ca. 7,5 mm auf 4,5 mm*

ENG: *Genuine Buffalo Leather* |

Seam: *cream white / matching stitching* | *Thickness of strap: approx. 7.5 mm to 4.5 mm*



207 **07**
mokka
mocha

207 **13**
schwarz
black

207
Rückseiten
Reverse sides



Länge Length (mm)		M	
		120	92
Breite Width			
Anstoß / Lug	Schließe / Buckle		
20 mm	20 mm	●	
22 mm	20 mm	▲	
24 mm	20 mm	◐	

Form Querschnitt | Cross-section:



Mod. 206 Advantage

DE: *Echt Büffelleder* |
 Naht: *Rot / Ton in Ton* | Bandstärke: *ca. 7,5 mm auf 4,5 mm*
 ENG: *Genuine Buffalo Leather* |
 Seam: *red / matching stitching* | Thickness of strap: *approx. 7.5 mm to 4.5 mm*



206 13
 schwarz
 black



206
 Rückseiten
 Reverse sides



Länge Length (mm)		M	
		114	82
Breite Width			
Anstoß / Lug	Schließe / Buckle		
18 mm	16 mm	●	
20 mm	18 mm	●	
22 mm	18 mm	▲	

Form Querschnitt | Cross-section:



Mod. 65 Montana

DE: *Echt Büffelleder* | »Art Manuel« |
 Naht: *Cremeweiß* | Bandstärke: *ca. 6,0 mm auf 3,0 mm*
 ENG: *Genuine Buffalo Leather* | »Art Manuel« |
 Seam: *cream white* | Thickness of strap: *approx. 6.0 mm to 3.0 mm*



65 06
 cognac
 cognac



65 07
 mokka
 mocha



65 13
 schwarz
 black



Mod. 64 | Colorado

DE: *Echt Büffelleder* | »Art Manuel« |
 Naht: *Ton in Ton* | Bandstärke: *ca. 6,0mm auf 3,0mm*
 ENG: *Genuine Buffalo Leather* | »Art Manuel« |
 Seam: *matching stitching* | *Thickness of strap: approx. 6.0mm to 3.0mm*



64 06 cognac
64 07 mokka
64 13 schwarz

Länge Length (mm)		M	
		114	82
Breite Width			
Anstoß / Lug	Schließe / Buckle		
18 mm	16 mm	●	
20 mm	18 mm	●	
22 mm	18 mm	▲	

Form Querschnitt | Cross-section:



»RUND« | »ROUND«



Mod. 61 | Nature

DE: *Echt Büffelleder* | »Handnaht« |
 Naht: *Cremeweiß* | Bandstärke: *ca. 6,0mm auf 5,0mm*
 ENG: *Genuine Buffalo Leather* | »Saddler's Seam (Hand Seam)« |
 Seam: *cream white* | *Thickness of strap: approx. 6.0mm to 5.0mm*



61 06 cognac Rückseite
61 07 mokka Rückseite
61 13 schwarz Rückseite

Länge Length (mm)		M	
		114	82
Breite Width			
Anstoß / Lug	Schließe / Buckle		
18 mm	18 mm	●	
20 mm	18 mm	●	
22 mm	18 mm	▲	

Form Querschnitt | Cross-section:



»ECKIG« | »SQUARE«



Länge Length (mm)		S		M	
		104	72	114	82
Breite Width					
Anstoß / Lug	Schließe / Buckle				
12 mm	10 mm	●			
14 mm	12 mm	●			
16 mm	14 mm			●	
18 mm	16 mm			●	
20 mm	18 mm			●	

Form Querschnitt | Cross-section:



»ECKIG« | »SQUARE«

Mod. 62 | Texas

DE: *Echt Büffelleder* |

Naht: *Ton in Ton* | Bandstärke: *ca. 3,5 mm auf 3,5 mm*

ENG: *Genuine Buffalo Leather* |

Seam: *matching stitching* | Thickness of strap: *approx. 3.5 mm to 3.5 mm*



62 06
cognac
cognac

62 07
mokka
mocha

62 11
bordeaux
burgundy

62 12
ozeanblau
ocean blue

62 13
schwarz
black



Länge Length (mm)		M	
		114	82
Breite Width			
Anstoß / Lug	Schließe / Buckle		
18 mm	16 mm		●
20 mm	18 mm		●
22 mm	20 mm		▲

Form Querschnitt | Cross-section:



»ECKIG« | »SQUARE«

Mod. 55 | Cashmere

DE: *Echt Lammleder* |

Naht: *Ton in Ton* | Bandstärke: *ca. 3,5 mm auf 3,5 mm*

ENG: *Genuine Lambskin* |

Seam: *matching stitching* | Thickness of strap: *approx. 3.5 mm to 3.5 mm*



55 03
steingrau
stone grey

55 06
cognac
cognac

55 07
mokka
mocha

55 12
ozeanblau
ocean blue

55 13
schwarz
black



Länge Length (mm)		S		M	
		104	72	114	82
Breite Width					
Anstoß / Lug	Schließe / Buckle				
14 mm	12 mm	●			
16 mm	14 mm	●			
18 mm	16 mm	●	●		
20 mm	18 mm		●		

Form Querschnitt | Cross-section:



Mod. 47 | Merino

DE: *Echt Lammleder* | »Art Manuel« |
 Naht: *Ton in Ton* | Bandstärke: *3,5 mm auf 3,0 mm*
 ENG: *Genuine Lambskin* | »Art Manuel« |
 Seam: *matching stitching* | Thickness of strap: *approx. 3.5 mm to 3.0 mm*



- 47 **03**
steingrau
stone grey
- 47 **06**
cognac
cognac
- 47 **07**
mokka
mocha
- 47 **12**
ozeanblau
ocean blue
- 47 **13**
schwarz
black



Länge Length (mm)		M	
		114	82
Breite Width			
Anstoß / Lug	Schließe / Buckle		
18 mm	16 mm		●
20 mm	18 mm		●
22 mm	18 mm		▲

Form Querschnitt | Cross-section:



Mod. 39 | Havana

DE: *Echt Schweinsleder* |
 Naht: *Cremeweiß* | Bandstärke: *ca. 3,5 mm auf 3,0 mm*
 ENG: *Genuine Pigskin* |
 Seam: *cream white* | Thickness of strap: *approx. 3.5 mm to 3.0 mm*



- 39 **06**
cognac
cognac
- 39 **07**
mokka
mocha
- 39 **13**
schwarz
black





Länge Length (mm)		M	
		114	82
Breite Width			
Anstoß / Lug	Schließe / Buckle		
18 mm	16 mm	●	
20 mm	18 mm	●	
22 mm	18 mm	▲	

Form Querschnitt | Cross-section:



»ECKIG« | »SQUARE«

Mod. **38** Tobacco

DE: *Echt Schweinsleder* |

Naht: *Ton in Ton* | Bandstärke: *ca. 3,5 mm auf 3,0 mm*

ENG: *Genuine Pigskin* |

Seam: *matching stitching* | *Thickness of strap: approx. 3.5 mm to 3.0 mm*



38 **06**
cognac
cognac



38 **07**
mokka
mocha



38 **13**
schwarz
black



38
Rückseiten
Reverse sides



Seite | Page 87
Mod. 207

A close-up photograph of two leather straps. The primary strap is a light tan color with prominent white stitching along its edges. It features a silver-toned metal buckle and a matching metal prong. A second, darker brown leather strap is partially visible behind it, also showing stitching. The background is a dark, textured surface, possibly leather or stone.

Seite | Page 92
Mod. 38

Seite | Page 91
Mod. 39



Prägung

Embossed Leather

Seite | Page 99

Mod. 51



Länge Length (mm)		S	M	XL
		104 72	114 82	116 86
Breite Width				
Anstoß / Lug	Schließe / Buckle			
08 mm	08 mm	●		■
10 mm	08 mm	●		■
12 mm	10 mm	●		■
14 mm	12 mm	●		■
16 mm	14 mm	●	●	■
17 mm	16 mm		●	■
18 mm	16 mm	●	●	■
19 mm	16 mm		●	■
20 mm	18 mm	●	●	■
22 mm	18 mm		▲	◆

XL = 124/92

Form Querschnitt | Cross-section:



Mod. 70 | Brazil

DE: Krokodilnarbung auf echt Rindsleder geprägt, in matt | Naht: Ton in Ton | Bandstärke: ca. 2,5 mm auf 2,5 mm

ENG: Embossed Crocodile Grain on Genuine Cow Leather, matt finish | Seam: matching stitching | Thickness of strap: approx. 2.5 mm to 2.5 mm

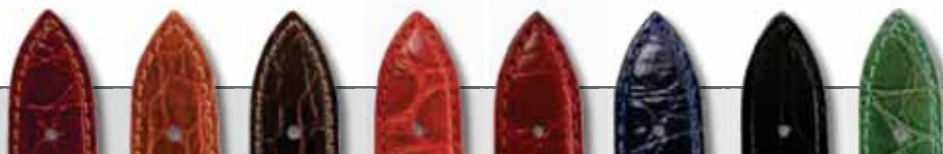

- 70 **05**
mahagoni
mahogany
- 70 **06**
cognac
cognac
- 70 **07**
mokka
mocha
- 70 **08**
rot
red
- 70 **11**
bordeaux
burgundy
- 70 **12**
ozeanblau
ocean blue
- 70 **13**
schwarz
black
- 70 **18**
apfelgrün
apple green



Länge Length (mm)		M	
		114	82
Breite Width			
Anstoß / Lug	Schließe / Buckle		
16 mm	14 mm		●
18 mm	16 mm		●
20 mm	18 mm		●

Form Querschnitt | Cross-section:



Mod. 60 | Ocean

DE: Haifischnarbung auf echt Rindsleder geprägt | Naht: Ton in Ton | Bandstärke: ca. 3,5 mm auf 3,5 mm

ENG: Embossed Shark Grain on Genuine Cow Leather | Seam: matching stitching | Thickness of strap: approx. 3.5 mm to 3.5 mm



- 60 **03**
steingrau
stone grey
- 60 **06**
cognac
cognac
- 60 **08**
rot
red
- 60 **10**
forstgrün
forest green
- 60 **11**
bordeaux
burgundy
- 60 **13**
schwarz
black
- 60 **18**
apfelgrün
apple green
- 60 **23**
royalblau
royal blue



Mod. 59 | Vegas

DE: Alligatorennarbung auf echt Rindsleder geprägt, in matt | »Art Manuel« | Naht: Farbig | Bandstärke: ca. 6,0mm auf 3,0mm

ENG: Embossed Alligator Grain on Genuine Cow Leather, matt finish | »Art Manuel« | Seam: coloured | Thickness of strap: approx. 6.0mm to 3.0mm



59 08 rot red
59 14 orange orange
59 16 gelb yellow
59 18 apfelgrün apple green
59 20 marineblau navy



59 08 Rückseite Reverse side
59 14 Rückseite Reverse side
59 16 Rückseite Reverse side
59 18 Rückseite Reverse side
59 20 Rückseite Reverse side

Länge Length (mm)		M	
		114	82
Breite Width			
Anstoß / Lug	Schließe / Buckle		
18 mm	16 mm	●	
19 mm	16 mm	●	
20 mm	18 mm	●	
22 mm	18 mm	▲	

Form Querschnitt | Cross-section:



»RUND« | »ROUND«



Mod. 58 | Baltimore

DE: Alligatorennarbung auf echt Rindsleder geprägt, in matt | Naht: Ton in Ton | Bandstärke: ca. 2,0mm auf 2,0mm

ENG: Embossed Alligator Grain on Genuine Cow Leather, matt finish | Seam: matching stitching | Thickness of strap: approx. 2.0mm to 2.0mm



58 05 mahagoni mahogany
58 06 cognac cognac
58 07 mokka mocha
58 11 bordeaux burgundy
58 13 schwarz black
58 20 marineblau navy

Länge Length (mm)		S	M
		104 72	114 82
Breite Width			
Anstoß / Lug	Schließe / Buckle		
17 mm	16 mm		●
18 mm	16 mm	●	●
19 mm	16 mm	●	●
20 mm	16 mm		●

Form Querschnitt | Cross-section:



»BLOCK« | »BLOCK«



Länge Length (mm)		M	
		114	82
Breite Width			
Anstoß / Lug	Schließe / Buckle		
18 mm	16 mm	●	
19 mm	16 mm	●	
20 mm	18 mm	●	
22 mm	18 mm	▲	

Form Querschnitt | Cross-section:



Mod. 57 | Boston

DE: Alligatorennarbung auf echt Rindsleder geprägt, in matt | Naht: Cremeweiß | Bandstärke: ca. 5,0 mm auf 3,0 mm

ENG: Embossed Alligator Grain on Genuine Cow Leather, matt finish | Seam: cream white | Thickness of strap: approx. 5.0 mm to 3.0 mm



- 57 **03**
steingrau
stone grey
- 57 **05**
mahagoni
mahogany
- 57 **06**
cognac
cognac
- 57 **07**
mokka
mocha
- 57 **13**
schwarz
black
- 57 **20**
marineblau
navy



57
Rückseiten
Reverse sides



Länge Length (mm)		M	
		114	82
Breite Width			
Anstoß / Lug	Schließe / Buckle		
18 mm	16 mm	●	
19 mm	16 mm	●	
20 mm	16 mm	●	
20 mm	18 mm	●	
21 mm	18 mm	▲	
22 mm	18 mm	▲	

Form Querschnitt | Cross-section:



Mod. 56 | Dallas

DE: Alligatorennarbung auf echt Rindsleder geprägt, in matt | Naht: Ton in Ton | Bandstärke: ca. 5,0 mm auf 3,0 mm

ENG: Embossed Alligator Grain on Genuine Cow Leather, matt finish | Seam: matching stitching | Thickness of strap: approx. 5.5 mm to 3.0 mm



- 56 **03**
steingrau
stone grey
- 56 **05**
mahagoni
mahogany
- 56 **06**
cognac
cognac
- 56 **07**
mokka
mocha
- 56 **13**
schwarz
black
- 56 **20**
marineblau
navy



56
Rückseiten
Reverse sides



Mod. 53 Panama

DE: Alligatorennarbung auf echt Rindsleder geprägt, in matt | »Art Manuel« | Naht: Cremeweiß | Bandstärke: ca. 3,5 mm auf 2,7 mm

ENG: Embossed Alligator Grain on Genuine Cow Leather, matt finish | »Art Manuel« | Seam: cream white | Thickness of strap: approx. 3.5 mm to 2.7 mm



53 05 mahagani mahogany
53 06 cognac cognac
53 07 mokka mocha
53 11 bordeaux burgundy
53 13 schwarz black
53 20 marineblau navy

Länge Length (mm)		S	M	XL
		104 72	114 82	116 86
Breite Width	Anstoß / Lug	Schließe / Buckle		
12 mm	10 mm	●		
14 mm	12 mm	●		
16 mm	14 mm		●	
18 mm	16 mm		●	
19 mm	16 mm		●	
20 mm	16 mm		●	
20 mm	18 mm		●	
22 mm	18 mm		▲	
24 mm	22 mm		▲	★

Form Querschnitt | Cross-section:



XL = 124 / 92



Mod. 52 Orlando

DE: Alligatorennarbung auf echt Rindsleder geprägt, in matt | »Art Manuel« | Naht: Ton in Ton | Bandstärke: ca. 3,5 mm auf 2,7 mm

ENG: Embossed Alligator Grain on Genuine Cow Leather, matt finish | »Art Manuel« | Seam: matching stitching | Thickness of strap: approx. 3.5 mm to 2.7 mm



52 01 weiß white
52 05 mahagani mahogany
52 06 cognac cognac
52 07 mokka mocha
52 11 bordeaux burgundy
52 13 schwarz black
52 20 marineblau navy

Länge Length (mm)		S	M	XL
		104 72	114 82	116 86
Breite Width	Anstoß / Lug	Schließe / Buckle		
12 mm	10 mm	●		
14 mm	12 mm	●		
16 mm	14 mm		●	
18 mm	16 mm		●	
19 mm	16 mm		●	
20 mm	16 mm		●	
20 mm	18 mm		●	
22 mm	18 mm		▲	
24 mm	22 mm		▲	★

Form Querschnitt | Cross-section:



XL = 124 / 92



Mod. 51 | New Orleans

DE: Alligatorennarbung auf echt Rindsleder geprägt, in matt | »Art Manuel« | Naht: Cremeweiß | Bandstärke: ca. 6,0mm auf 3,0mm

ENG: Embossed Alligator Grain on Genuine Cow Leather, matt finish | »Art Manuel« | Seam: cream white | Thickness of strap: approx. 6.0mm to 3.0mm

Länge Length (mm)		S		M		XL	
		104	72	114	82	124	92
Breite Width							
Anstoß / Lug	Schließe / Buckle						
16mm	14mm	●		●		■	
18mm	16mm	●		●		■	
19mm	16mm			●			
20mm	18mm	●		●		■	
22mm	18mm	▲		▲		◆	

Form Querschnitt | Cross-section:



»RUND« | »ROUND«



- 51 **02**
sand
sand
- 51 **03**
steingrau
stone grey
- 51 **05**
mahagoni
mahogany
- 51 **06**
cognac
cognac
- 51 **07**
mokka
mocha
- 51 **09**
rosa
pale pink
- 51 **11**
bordeaux
burgundy
- 51 **13**
schwarz
black
- 51 **14**
orange
orange
- 51 **17**
türkis
turquoise
- 51 **19**
eisblau
ice blue
- 51 **20**
marineblau
navy



Mod. 50 | Louisiana

DE: Alligatorennarbung auf echt Rindsleder geprägt, in matt | »Art Manuel« | Naht: Ton in Ton | Bandstärke: ca. 6,0mm auf 3,0mm

ENG: Embossed Alligator Grain on Genuine Cow Leather, matt finish | »Art Manuel« | Seam: matching stitching | Thickness of strap: approx. 6.0mm to 3.0mm

Länge Length (mm)		S		M		XL	
		104	72	114	82	124	92
Breite Width							
Anstoß / Lug	Schließe / Buckle						
16mm	14mm	●		●		■	
18mm	16mm	●		●		■	
19mm	16mm			●			
20mm	16mm			●			
20mm	18mm	●		●		■	
21mm	18mm			▲			
22mm	18mm	▲		▲		◆	

Form Querschnitt | Cross-section:



»RUND« | »ROUND«



- 50 **01**
weiß
white
- 50 **02**
sand
sand
- 50 **03**
steingrau
stone grey
- 50 **05**
mahagoni
mahogany
- 50 **06**
cognac
cognac
- 50 **07**
mokka
mocha
- 50 **09**
rosa
pale pink
- 50 **11**
bordeaux
burgundy
- 50 **13**
schwarz
black
- 50 **14**
orange
orange
- 50 **17**
türkis
turquoise
- 50 **19**
eisblau
ice blue
- 50 **20**
marineblau
navy



Länge Length (mm)		S		M	
		104	72	114	82
Breite Width					
Anstoß / Lug	Schließe / Buckle				
12 mm	10 mm	●			
14 mm	12 mm	●			
16 mm	14 mm	●	●		
18 mm	16 mm	●	●		
20 mm	18 mm	●	●		
22 mm	20 mm		▲		

Form Querschnitt | Cross-section:



»ECKIG« | »SQUARE«

Mod. 49 | Argentina

DE: Alligatorennarbung auf echt Rindsleder geprägt, in glanz |
Naht: Ton in Ton | Bandstärke: ca. 3,5 mm auf 3,5 mm

ENG: Embossed Alligator Grain on Genuine Cow Leather, glossy finish |
Seam: matching stitching | Thickness of strap: approx. 3.5 mm to 3.5 mm



49 01 weiß white | 49 02 sand sand | 49 05 mahagoni mahogany | 49 06 cognac cognac | 49 07 mokka mocha | 49 09 rosa pale pink | 49 10 forstgrün forest green | 49 13 schwarz black | 49 14 orange orange | 49 17 türkis turquoise | 49 19 eisblau ice blue | 49 20 marineblau navy



Länge Length (mm)		S		M	
		104	72	114	82
Breite Width					
Anstoß / Lug	Schließe / Buckle				
12 mm	10 mm	●			
14 mm	12 mm	●			
16 mm	14 mm		●		
18 mm	16 mm		●		
20 mm	18 mm		●		
22 mm	20 mm		▲		

Form Querschnitt | Cross-section:



»ECKIG« | »SQUARE«

| Spangband | | Clasp strap |

Schnelles und einfaches Wechseln
Der Federsteg muss nicht ausgebaut werden

A fast and easy system to change the clasp
The pin does not have to be removed

Mod. 49S | Argentina »mit Spange« | »with clasp«

DE: Alligatorennarbung auf echt Rindsleder geprägt, in glanz |
Naht: Ton in Ton | Bandstärke: ca. 3,5 mm auf 3,5 mm

ENG: Embossed Alligator Grain on Genuine Cow Leather, glossy finish |
Seam: matching stitching | Thickness of strap: approx. 3.5 mm to 3.5 mm



49S 05 mahagoni mahogany | 49S 06 cognac cognac | 49S 07 mokka mocha | 49S 10 forstgrün forest green | 49S 13 schwarz black | 49S 20 marineblau navy



Länge Length (mm)		S		M	
		104	72	114	82
Breite Width					
Anstoß / Lug	Schließe / Buckle				
12mm	10mm	●			
14mm	12mm	●			
16mm	14mm	●	●		
18mm	16mm	●	●		
20mm	18mm	●	●		

Form Querschnitt | Cross-section:



Mod. 48 | Durban

DE: *Straußennarbung auf echt Rindsleder geprägt |*

Naht: *Ton in Ton | Bandstärke: ca. 3,5mm auf 3,5mm*

ENG: *Embossed Ostrich Grain on Genuine Cow Leather |*

Seam: *matching stitching | Thickness of strap: approx. 3.5mm to 3.5mm*



Länge Length (mm)		S		M	
		104	72	114	82
Breite Width					
Anstoß / Lug	Schließe / Buckle				
10mm	08mm	●			
12mm	10mm	●			
14mm	12mm	●			
16mm	14mm	●	●		
18mm	16mm	●	●		
20mm	18mm	●	●		

Form Querschnitt | Cross-section:



Mod. 42 | Bolivia

DE: *Teju-Eidechsennarbung auf echt Rindsleder geprägt |*

Naht: *Ohne | Bandstärke: ca. 2,5mm auf 2,5mm*

ENG: *Embossed Teju Lizard Grain on Genuine Cow Leather |*

Seam: *no stitching | Thickness of strap: approx. 2.5mm to 2.5mm*





Mit Kantenlack
With Edge Colour



Länge Length (mm)		M	
		114	82
Breite Width			
Anstoß / Lug	Schließe / Buckle		
18 mm	16 mm	●	
19 mm	16 mm	●	
20 mm	16 mm	●	
22 mm	18 mm	▲	

Form Querschnitt | Cross-section:



»BLOCK« | »BLOCK«

RIOS1931 Handnaht
Von innen vernäht!

RIOS1931 Saddler's Seam
Sewed from inside!

Mod. 37 | Hollywood

DE: Alligatorennarbung auf echt Rindsleder geprägt, in matt | »Handnaht« | Naht: Cremeweiß | Bandstärke: ca. 2,7 mm auf 2,7 mm

ENG: Embossed Alligator Grain on Genuine Cow Leather, matt finish | »Saddler's Seam (Hand Seam)« | Seam: cream white | Thickness of strap: approx. 2.7 mm to 2.7 mm



37 05
mahagoni
mahogany

37 06
cognac
cognac

37 07
mokka
mocha

37 13
schwarz
black



Länge Length (mm)		M	
		120	92
Breite Width			
Anstoß / Lug	Schließe / Buckle		
20 mm	20 mm	●	
22 mm	20 mm	▲	
24 mm	20 mm	◐	

Form Querschnitt | Cross-section:



»RUND« | »ROUND«

Mod. 36 | Monza

DE: Carbonlook auf echt Rindsleder geprägt | Naht: Rot | Bandstärke: ca. 7,5 mm auf 4,5 mm

ENG: Embossed Carbon Look Grain on Genuine Cow Leather | Seam: red | Thickness of strap: approx. 7.5 mm to 4.5 mm



36 13
schwarz
black



36
Rückseiten
Reverse sides



Länge Length (mm)		S		M	
		104	72	114	82
Breite Width					
Anstoß / Lug	Schließe / Buckle				
12 mm	10 mm	●			
14 mm	12 mm	●			
16 mm	14 mm	●	●		
18 mm	16 mm	●	●		
20 mm	18 mm	●	●		

Form Querschnitt | Cross-section:



»BLOCK« | »BLOCK«

Mod. 35 | Miami

DE: Alligatorennarbung auf echt Rindsleder geprägt, in matt | Naht: Ohne | Bandstärke: ca. 2,0mm auf 2,0mm

ENG: Embossed Alligator Grain on Genuine Cow Leather, matt finish | Seam: no stitching | Thickness of strap: approx. 2.0mm to 2.0mm



- 35 **01**
weiß
white
- 35 **02**
sand
sand
- 35 **03**
steingrau
stone grey
- 35 **05**
mahagoni
mahogany
- 35 **06**
cognac
cognac
- 35 **07**
mokka
mocha
- 35 **09**
rosa
pale pink
- 35 **11**
bordeaux
burgundy
- 35 **13**
schwarz
black
- 35 **14**
orange
orange
- 35 **17**
türkis
turquoise
- 35 **19**
eisblau
ice blue
- 35 **20**
marineblau
navy



Länge Length (mm)		M	
		120	92
Breite Width			
Anstoß / Lug	Schließe / Buckle		
20 mm	20 mm		●
22 mm	20 mm		▲
24 mm	20 mm		◐

Form Querschnitt | Cross-section:



»RUND« | »ROUND«

Mod. 33 | Silverstone

DE: Carbonlook auf echt Rindsleder geprägt | Naht: Cremeweiß | Bandstärke: ca. 7,5mm auf 4,5mm

ENG: Embossed Carbon Look Grain on Genuine Cow Leather | Seam: cream white | Thickness of strap: approx. 7.5mm to 4.5mm



33 **13**
schwarz
black



33
Rückseiten
Reverse sides



Länge Length (mm)		M	
Breite Width		120	92
Anstoß / Lug	Schließe / Buckle		
20 mm	20 mm	●	
22 mm	20 mm	▲	
24 mm	20 mm	◐	

Form Querschnitt | Cross-section:



»RUND« | »ROUND«

Mod. 32 | Montreal

DE: Carbonlook auf echt Rindsleder geprägt |

Naht: Ton in Ton | Bandstärke: ca. 7,5 mm auf 4,5 mm

ENG: Embossed Carbon Look Grain on Genuine Cow Leather |

Seam: matching stitching | Thickness of strap: approx. 7.5 mm to 4.5 mm



32 13
schwarz
black



32
Rückseiten
Reverse sides



Mod. 31 | Imola

DE: Carbonlook auf echt Rindsleder geprägt | »Art Manuel« |

Naht: Ton in Ton | Bandstärke: ca. 6,0 mm auf 3,0 mm

ENG: Embossed Carbon Look Grain on Genuine Cow Leather | »Art Manuel« |

Seam: matching stitching | Thickness of strap: approx. 6.0 mm to 3.0 mm



31 13
schwarz
black



31
Rückseiten
Reverse sides

Länge Length (mm)		M	
Breite Width		114	82
Anstoß / Lug	Schließe / Buckle		
18 mm	16 mm	●	
19 mm	16 mm	●	
20 mm	18 mm	●	
22 mm	20 mm	▲	

Form Querschnitt | Cross-section:



»RUND« | »ROUND«



Seite | Page 102
Mod. 36

Seite | Page 104
Mod. 32

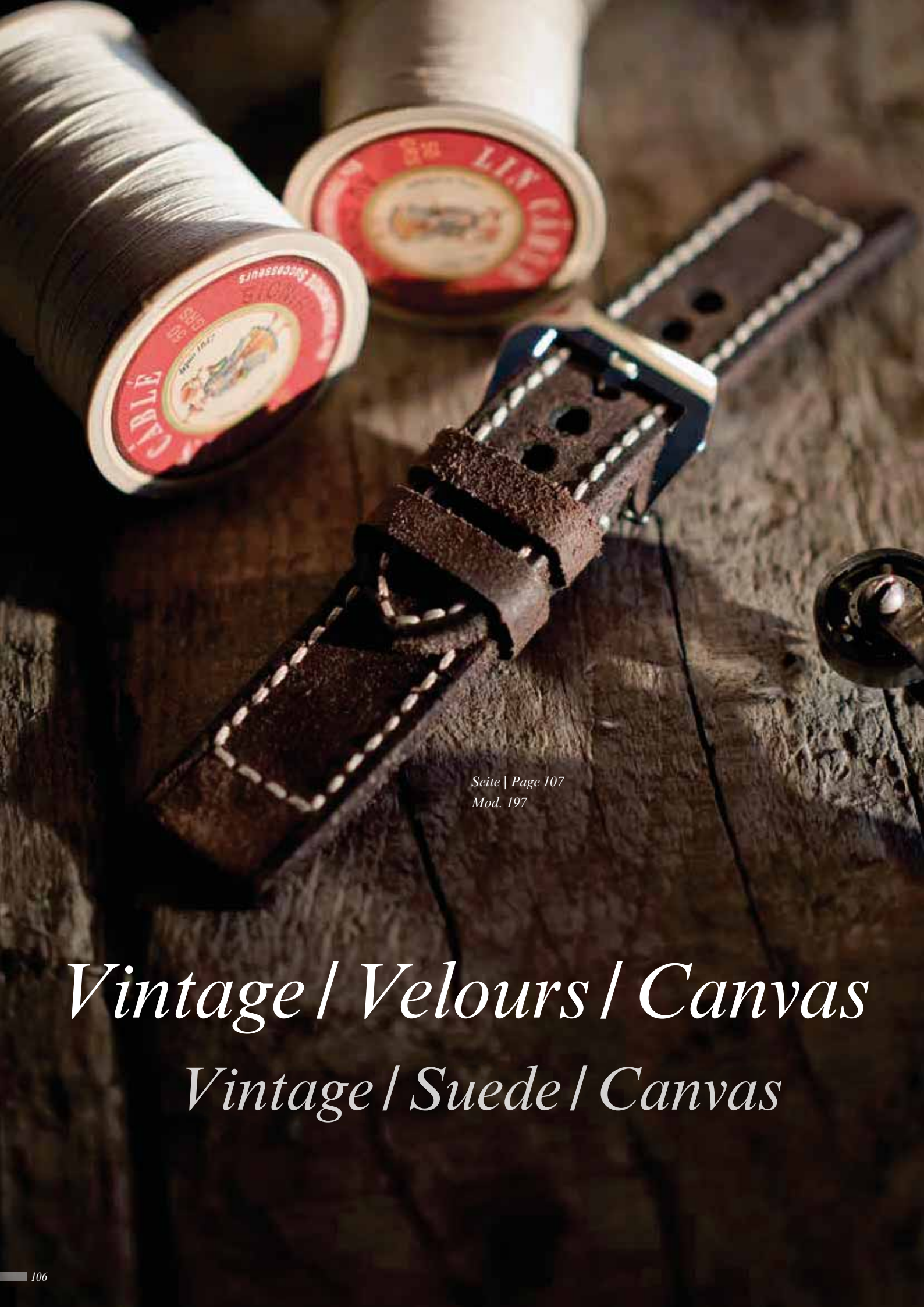

Seite | Page 107
Mod. 197

Vintage / Velours / Canvas
Vintage / Suede / Canvas



– Lieferung OHNE Schließe –
Bitte wählen Sie auf den
Seiten 182/183



– Supplied WITHOUT clasp –
Please select a clasp on
pages 182/183

Länge Length (mm)		M	
		114	82
Breite Width			
Anstoß / Lug	Schließe / Buckle		
22 mm	22 mm	▲	
24 mm	22 mm	◐	
24 mm	24 mm	◑	

Form Querschnitt | Cross-section:



»BLOCK« | »BLOCK«

- Jedes Band ist ein Unikat –
Die Patina des Vintageleders kann
stark unterschiedlich ausfallen.
- Every watch strap is unique –
The patina of the vintage leather
can strongly vary.

Mod. 197 | **Liverpool**

DE: *Echt Vintageleder* | »Handnaht« |
Naht: *Cremeweiß* | Bandstärke: ca. 4,0 mm auf 4,0 mm
ENG: *Genuine Vintage Leather* | »Saddler's Seam (Hand Seam)« |
Seam: *cream white* | Thickness of strap: approx. 4.0 mm to 4.0 mm



197 **03** steingrau / stone grey
197 **04** honig / honey
197 **05** mahagoni / mahogany
197 **06** cognac / cognac
197 **07** mokka / mocha
197 **13** schwarz / black



197
Rückseiten
Reverse sides



– Lieferung OHNE Schließe –
Bitte wählen Sie auf den
Seiten 182/183



– Supplied WITHOUT clasp –
Please select a clasp on
pages 182/183

Länge Length (mm)		M		XL
		114	82	124 92
Breite Width				
Anstoß / Lug	Schließe / Buckle			
22 mm	22 mm	▲		◆
24 mm	22 mm	◐		★
24 mm	24 mm	◑		★

Form Querschnitt | Cross-section:



»BLOCK« | »BLOCK«

- Jedes Band ist ein Unikat –
Die Patina des Vintageleders kann
stark unterschiedlich ausfallen.
- Every watch strap is unique –
The patina of the vintage leather
can strongly vary.

Mod. 196 | **Manchester**

DE: *Echt Vintageleder* | »Handnaht« |
Naht: *Cremeweiß* | Bandstärke: ca. 4,0 mm auf 4,0 mm
ENG: *Genuine Vintage Leather* | »Saddler's Seam (Hand Seam)« |
Seam: *cream white* | Thickness of strap: approx. 4.0 mm to 4.0 mm



196 **03** steingrau / stone grey
196 **04** honig / honey
196 **05** mahagoni / mahogany
196 **06** cognac / cognac
196 **07** mokka / mocha
196 **13** schwarz / black



196
Rückseiten
Reverse sides



– Lieferung OHNE Schließe –
Bitte wählen Sie auf den
Seiten 182/183



– Supplied WITHOUT clasp –
Please select a clasp on
pages 182/183

Länge Length (mm)		M	
		114	82
Breite Width			
Anstoß / Lug	Schließe / Buckle		
20 mm	20 mm	●	
22 mm	22 mm	▲	
24 mm	22 mm	◐	
24 mm	24 mm	◑	

Form Querschnitt | Cross-section:



»BLOCK« | »BLOCK«

– Jedes Band ist ein Unikat –
Die Patina des Vintageleders kann
stark unterschiedlich ausfallen.

– Every watch strap is unique –
The patina of the vintage leather
can strongly vary.

Mod. 195 | Newcastle

DE: *Echt Vintageleder* | »Handnaht« |
Naht: Cremeweiß | Bandstärke: ca. 4,0mm auf 4,0mm

ENG: *Genuine Vintage Leather* | »Saddler's Seam (Hand Seam)« |
Seam: cream white | Thickness of strap: approx. 4.0mm to 4.0mm



195 03 steingrau stone grey
195 04 honig honey
195 05 mahagoni mahogany
195 06 cognac cognac
195 07 mokka mocha
195 13 schwarz black



195
Rückseiten
Reverse sides



– Lieferung OHNE Schließe –
Bitte wählen Sie auf den
Seiten 182/183



– Supplied WITHOUT clasp –
Please select a clasp on
pages 182/183

Länge Length (mm)		M	
		114	82
Breite Width			
Anstoß / Lug	Schließe / Buckle		
22 mm	22 mm	▲	
24 mm	24 mm	◑	

Form Querschnitt | Cross-section:



»BLOCK« | »BLOCK«

– Jedes Band ist ein Unikat –
Die Patina des Vintageleders kann
stark unterschiedlich ausfallen.

– Every watch strap is unique –
The patina of the vintage leather
can strongly vary.

Mod. 194 | Chesterfield

DE: *Echt Vintageleder mit zwei Nieten* |
Naht: Cremeweiß | Bandstärke: ca. 4,0mm auf 4,0mm

ENG: *Genuine Vintage Leather with two rivets* |
Seam: cream white | Thickness of strap: approx. 4.0mm to 4.0mm



194 03 steingrau stone grey
194 04 honig honey
194 05 mahagoni mahogany
194 06 cognac cognac
194 07 mokka mocha
194 13 schwarz black



– Lieferung OHNE Schließe –
Bitte wählen Sie auf den
Seiten 182 / 183



– Supplied WITHOUT clasp –
Please select a clasp on
pages 182 / 183

Länge Length (mm)		M	
		114	82
Breite Width			
Anstoß / Lug	Schließe / Buckle		
18 mm	16 mm	●	
20 mm	18 mm	●	
22 mm	22 mm	▲	
24 mm	24 mm	◐	

Form Querschnitt | Cross-section:



»BLOCK« | »BLOCK«

- Jedes Band ist ein Unikat –
Die Patina des Vintageleders kann
stark unterschiedlich ausfallen.
- Every watch strap is unique –
The patina of the vintage leather
can strongly vary.

Mod. 192 | London

DE: *Echt Vintageleder mit einer Niete* |
Naht: *Cremeweiß* | Bandstärke: *ca. 4,0mm auf 4,0mm*
ENG: *Genuine Vintage Leather with one rivet* |
Seam: *cream white* | Thickness of strap: *approx. 4.0mm to 4.0mm*



192 **03** steingrau stone grey
192 **04** honig honey
192 **05** mahagoni mahogany
192 **06** cognac cognac
192 **07** mokka mocha
192 **13** schwarz black



– Lieferung OHNE Schließe –
Bitte wählen Sie auf den
Seiten 182 / 183



– Supplied WITHOUT clasp –
Please select a clasp on
pages 182 / 183

Länge Length (mm)		M	
		114	82
Breite Width			
Anstoß / Lug	Schließe / Buckle		
18 mm	16 mm	●	
20 mm	18 mm	●	
22 mm	22 mm	▲	
24 mm	24 mm	◐	

Form Querschnitt | Cross-section:



»BLOCK« | »BLOCK«

- Jedes Band ist ein Unikat –
Die Patina des Vintageleders kann
stark unterschiedlich ausfallen.
- Every watch strap is unique –
The patina of the vintage leather
can strongly vary.

Mod. 190 | Oxford

DE: *Echt Vintageleder* |
Naht: *Cremeweiß* | Bandstärke: *ca. 4,0mm auf 4,0mm*
ENG: *Genuine Vintage Leather* |
Seam: *cream white* | Thickness of strap: *approx. 4.0mm to 4.0mm*



190 **03** steingrau stone grey
190 **04** honig honey
190 **05** mahagoni mahogany
190 **06** cognac cognac
190 **07** mokka mocha
190 **13** schwarz black



– Lieferung OHNE Schließe –
Bitte wählen Sie auf den
Seiten 182/183



– Supplied WITHOUT clasp –
Please select a clasp on
pages 182/183

Länge Length (mm)		M	
		114	82
Breite Width			
Anstoß / Lug	Schließe / Buckle		
20 mm	20 mm	●	
22 mm	22 mm	▲	
24 mm	22 mm	◐	
24 mm	24 mm	◑	

Form Querschnitt | Cross-section:



»RUND« | »ROUND«

– Jedes Band ist ein Unikat –
Die Patina des Vintageleders kann
stark unterschiedlich ausfallen.

– Every watch strap is unique –
The patina of the vintage leather
can strongly vary.

Mod. 188 | **Derby**

DE: *Echt Vintageleder* |

Naht: *Ton in Ton* | Bandstärke: *ca. 6,0mm auf 3,0mm*

ENG: *Genuine Vintage Leather* |

Seam: *matching stitching* | Thickness of strap: *approx. 6.0mm to 3.0mm*



188 03
steingrau
stone grey

188 04
honig
honey

188 05
mahagoni
mahogany

188 06
cognac
cognac

188 07
mokka
mocha

188 13
schwarz
black



188
Rückseiten
Reverse sides



– Lieferung OHNE Schließe –
Bitte wählen Sie auf den
Seiten 182/183



– Supplied WITHOUT clasp –
Please select a clasp on
pages 182/183

Länge Length (mm)		M	
		114	82
Breite Width			
Anstoß / Lug	Schließe / Buckle		
22 mm	22 mm	▲	
24 mm	24 mm	◑	

Form Querschnitt | Cross-section:



»BLOCK« | »BLOCK«

– Jedes Band ist ein Unikat –
Die Patina des Vintage Canvas kann
stark unterschiedlich ausfallen.
Dieses Band bekommt durch das Tragen einen
– Used-Look –

– Every watch strap is unique –
The patina of the vintage canvas
can strongly vary.
Wearing this strap will give it a
– used look –

Mod. 187 | **Indiana**

DE: *Echt Canvas / Vintage* | »Handnaht« |

Naht: *Cremeweiß* | Bandstärke: *ca. 4,0mm auf 3,0mm*

ENG: *Genuine Canvas / Vintage* | »Saddler's Seam (Hand Seam)« |

Seam: *cream white* | Thickness of strap: *approx. 4.0mm to 3.0mm*



187 03
steingrau
stone grey

187 04
honig
honey

187 06
cognac
cognac

187 07
mokka
mocha

187 13
schwarz
black

187 15
natogrün
drab olive



187
Rückseiten
Reverse sides



– Lieferung OHNE Schließe –
Bitte wählen Sie auf den
Seiten 182/183



– Supplied WITHOUT clasp –
Please select a clasp on
pages 182/183

Länge Length (mm)		M	
		114	82
Breite Width			
Anstoß / Lug	Schließe / Buckle		
22 mm	22 mm	▲	
24 mm	24 mm	◐	

Form Querschnitt | Cross-section:



»BLOCK« | »BLOCK«

– Jedes Band ist ein Unikat –
Die Patina des Vintage Canvas kann
stark unterschiedlich ausfallen.
Dieses Band bekommt durch das Tragen einen
– Used-Look –

– Every watch strap is unique –
The patina of the vintage canvas
can strongly vary.
Wearing this strap will give it a
– used look –

Mod. 186 Maryland

DE: *Echt Canvas / Vintage* | »Handnaht« |

Naht: *Ton in Ton* | Bandstärke: *ca. 4,0mm auf 3,0mm*

ENG: *Genuine Canvas / Vintage* | »Saddler's Seam (Hand Seam)« |

Seam: *matching stitching* | Thickness of strap: *approx. 4.0mm to 3.0mm*



186 03
steingrau
stone grey

186 04
honig
honey

186 06
cognac
cognac

186 07
mokka
mocha

186 13
schwarz
black

186 15
natogrün
drab olive



186
Rückseiten
Reverse sides



– Lieferung OHNE Schließe –
Bitte wählen Sie auf den
Seiten 182/183



– Supplied WITHOUT clasp –
Please select a clasp on
pages 182/183

Länge Length (mm)		M	
		114	82
Breite Width			
Anstoß / Lug	Schließe / Buckle		
20 mm	20 mm	●	
22 mm	22 mm	▲	
24 mm	24 mm	◐	

Form Querschnitt | Cross-section:



»BLOCK« | »BLOCK«

Dieses Band bekommt durch
das Tragen einen
– Used-Look –

Wearing this strap
will give it a
– used look –

Mod. 185 Ohio

DE: *Echt Canvas* | »Handnaht« |

Naht: *Cremeweiß* | Bandstärke: *ca. 4,0mm auf 3,0mm*

ENG: *Genuine Canvas* | »Saddler's Seam (Hand Seam)« |

Seam: *cream white* | Thickness of strap: *approx. 4.0mm to 3.0mm*



185 03
steingrau
stone grey

185 04
honig
honey

185 06
cognac
cognac

185 07
mokka
mocha

185 13
schwarz
black

185 15
natogrün
drab olive



185
Rückseiten
Reverse sides



Mod. 184 | **Virginia**

DE: *Echt Canvas* | »Handnaht« |
 Naht: *Ton in Ton* | Bandstärke: ca. 4,0mm auf 3,0mm
 ENG: *Genuine Canvas* | »Saddler's Seam (Hand Seam)« |
 Seam: *matching stitching* | Thickness of strap: approx. 4.0mm to 3.0mm

– Lieferung OHNE Schließe –
 Bitte wählen Sie auf den
 Seiten 182/183



– Supplied WITHOUT clasp –
 Please select a clasp on
 pages 182/183

Länge Length (mm)		M	
		114	82
Breite Width			
Anstoß / Lug	Schließe / Buckle		
20 mm	20 mm	●	
22 mm	22 mm	▲	
24 mm	24 mm	◐	

Form Querschnitt | Cross-section:



»BLOCK« | »BLOCK«

Dieses Band bekommt durch
 das Tragen einen
 – Used-Look –

Wearing this strap
 will give it a
 – used look –



184 03 steingrau stone grey
 184 04 honig honey
 184 06 cognac cognac
 184 07 mokka mocha
 184 13 schwarz black
 184 15 natogrün drab olive



184
 Rückseiten
 Reverse sides



Mod. 183 | **Georgia**

DE: *Echt Vintageleder* | »Handnaht« |
 Naht: *Cremeweiß* | Bandstärke: ca. 4,0mm auf 4,0mm
 ENG: *Genuine Vintage Leather* | »Saddler's Seam (Hand Seam)« |
 Seam: *cream white* | Thickness of strap: approx. 4.0mm to 4.0mm

– Lieferung OHNE Schließe –
 Bitte wählen Sie auf den
 Seiten 182/183



– Supplied WITHOUT clasp –
 Please select a clasp on
 pages 182/183

Länge Length (mm)		M	
		114	82
Breite Width			
Anstoß / Lug	Schließe / Buckle		
20 mm	20 mm	●	
22 mm	22 mm	▲	
24 mm	24 mm	◐	

Form Querschnitt | Cross-section:



»BLOCK« | »BLOCK«

– Jedes Band ist ein Unikat –
 Die Patina des Vintageleders kann
 stark unterschiedlich ausfallen.

– Every watch strap is unique –
 The patina of the vintage leather
 can strongly vary.



183 03 steingrau stone grey
 183 04 honig honey
 183 05 mahagoni mahogany
 183 06 cognac cognac
 183 07 mokka mocha
 183 13 schwarz black



183
 Rückseiten
 Reverse sides



– Lieferung OHNE Schließe –
Bitte wählen Sie auf den
Seiten 182 / 183



– Supplied WITHOUT clasp –
Please select a clasp on
pages 182 / 183

Länge Length (mm)		M	
		114	82
Breite Width			
Anstoß / Lug	Schließe / Buckle		
20 mm	20 mm	●	
22 mm	22 mm	▲	
24 mm	24 mm	◐	

Form Querschnitt | Cross-section:



»BLOCK« | »BLOCK«

- Jedes Band ist ein Unikat –
Die Patina des Vintageleders kann
stark unterschiedlich ausfallen.
- Every watch strap is unique –
The patina of the vintage leather
can strongly vary.

Mod. 182 | New Hampton

DE: *Echt Vintageleder* | »Handnaht« |
Naht: *Ton in Ton* | Bandstärke: *ca. 4,0mm auf 4,0mm*
ENG: *Genuine Vintage Leather* | »Saddler's Seam (Hand Seam)« |
Seam: *matching stitching* | Thickness of strap: *approx. 4.0mm to 4.0mm*



182 03
steingrau
stone grey



182 04
honig
honey



182 05
mahagoni
mahogany



182 06
cognac
cognac



182 07
mokka
mocha



182 13
schwarz
black



182
Rückseiten
Reverse sides



– Lieferung OHNE Schließe –
Bitte wählen Sie auf den
Seiten 182 / 183



– Supplied WITHOUT clasp –
Please select a clasp on
pages 182 / 183

Länge Length (mm)		M	
		114	82
Breite Width			
Anstoß / Lug	Schließe / Buckle		
22 mm	22 mm	▲	
24 mm	22 mm	◐	
24 mm	24 mm	◐	

Form Querschnitt | Cross-section:



»BLOCK« | »BLOCK«

- Jedes Band ist ein Unikat –
Die Patina des Vintageleders kann
stark unterschiedlich ausfallen.
- Every watch strap is unique –
The patina of the vintage leather
can strongly vary.

Mod. 180 | Belfast

DE: *Echt Vintageleder* | »Handnaht« |
Naht: *Schwarz* | Bandstärke: *ca. 4,0mm auf 4,0mm*
ENG: *Genuine Vintage Leather* | »Saddler's Seam (Hand Seam)« |
Seam: *black* | Thickness of strap: *approx. 4.0mm to 4.0mm*



180 03
steingrau
stone grey



180 04
honig
honey



180 05
mahagoni
mahogany



180 06
cognac
cognac



180 07
mokka
mocha



180 13
schwarz
black



180
Rückseiten
Reverse sides



– Lieferung OHNE Schließe –
Bitte wählen Sie auf den
Seiten 182/183



– Supplied WITHOUT clasp –
Please select a clasp on
pages 182/183

Länge Length (mm)		M	
		114	82
Breite Width			
Anstoß / Lug	Schließe / Buckle		
20 mm	20 mm	●	
22 mm	22 mm	▲	
24 mm	24 mm	◐	

Form Querschnitt | Cross-section:



»BLOCK« | »BLOCK«

– Jedes Band ist ein Unikat –
Die Patina des Vintageleders kann
stark unterschiedlich ausfallen.

– Every watch strap is unique –
The patina of the vintage leather
can strongly vary.

Mod. 179 | **Birmingham**

DE: *Echt Vintageleder* |
Naht: *Cremeweiß* | Bandstärke: *ca. 3,0mm auf 3,0mm*
ENG: *Genuine Vintage Leather* |
Seam: *cream white* | Thickness of strap: *approx. 3.0mm to 3.0mm*



179 **03** steingrau / stone grey
179 **04** honig / honey
179 **05** mahagoni / mahogany
179 **06** cognac / cognac
179 **07** mokka / mocha
179 **13** schwarz / black



179
Rückseiten
Reverse sides



– Lieferung OHNE Schließe –
Bitte wählen Sie auf den
Seiten 182 / 183



– Supplied WITHOUT clasp –
Please select a clasp on
pages 182 / 183

Länge Length (mm)		M	
		114	82
Breite Width			
Anstoß / Lug	Schließe / Buckle		
22 mm	22 mm	▲	
24 mm	22 mm	◐	
24 mm	24 mm	◑	

Form Querschnitt | Cross-section:

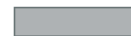

»BLOCK« | »BLOCK«

– Jedes Band ist ein Unikat –
Die Patina des Vintageleders kann
stark unterschiedlich ausfallen.

– Every watch strap is unique –
The patina of the vintage leather
can strongly vary.

Mod. 177 | **Winchester**

DE: *Echt Vintageleder* |
Naht: *Cremeweiß* | Bandstärke: *ca. 3,0mm auf 3,0mm*
ENG: *Genuine Vintage Leather* |
Seam: *cream white* | Thickness of strap: *approx. 3.0mm to 3.0mm*



177 **03** steingrau / stone grey
177 **04** honig / honey
177 **05** mahagoni / mahogany
177 **06** cognac / cognac
177 **07** mokka / mocha
177 **13** schwarz / black



177
Rückseiten
Reverse sides



Mod. 175 | York

DE: *Echt Vintageleder* | »Art Manuel« |
 Naht: *Cremeweiß* | Bandstärke: *ca. 7,0 mm auf 3,0 mm*
 ENG: *Genuine Vintage Leather* | »Art Manuel« |
 Seam: *cream white* | Thickness of strap: *approx. 7.0 mm to 3.0 mm*



175 **03** steingrau stone grey
 175 **04** honig honey
 175 **05** mahagoni mahogany
 175 **06** cognac cognac
 175 **07** mokka mocha
 175 **13** schwarz black

Länge Length (mm)		M	
		114	82
Breite Width			
Anstoß / Lug	Schließe / Buckle		
20 mm	18 mm	●	
22 mm	18 mm	▲	
22 mm	20 mm	▲	

Form Querschnitt | Cross-section:



»RUND« | »ROUND«

- Jedes Band ist ein Unikat – Die Patina des Vintageleders kann stark unterschiedlich ausfallen.
- Every watch strap is unique – The patina of the vintage leather can strongly vary.



– Lieferung OHNE Schließe – Bitte wählen Sie auf den Seiten 182 / 183



– Supplied WITHOUT clasp – Please select a clasp on pages 182 / 183

Länge Length (mm)		M	
		114	82
Breite Width			
Anstoß / Lug	Schließe / Buckle		
20 mm	20 mm	●	
22 mm	22 mm	▲	
24 mm	24 mm	◐	

Form Querschnitt | Cross-section:



»BLOCK« | »BLOCK«

- Jedes Band ist ein Unikat – Die Patina des Vintageleders kann stark unterschiedlich ausfallen.
- Every watch strap is unique – The patina of the vintage leather can strongly vary.

Mod. 173 | Westminster

DE: *Echt Vintageleder* |
 Naht: *Cremeweiß* | Bandstärke: *ca. 4,0 mm auf 4,0 mm*
 ENG: *Genuine Vintage Leather* |
 Seam: *cream white* | Thickness of strap: *approx. 4.0 mm to 4.0 mm*



173 **03** steingrau stone grey
 173 **05** mahagoni mahogany
 173 **06** cognac cognac
 173 **07** mokka mocha
 173 **13** schwarz black



– Lieferung OHNE Schließe –
Bitte wählen Sie auf den
Seiten 182/183



– Supplied WITHOUT clasp –
Please select a clasp on
pages 182/183

Länge Length (mm)		M	
		114	82
Breite Width			
Anstoß / Lug	Schließe / Buckle		
20 mm	20 mm	●	
22 mm	22 mm	▲	
24 mm	24 mm	◐	

Form Querschnitt | Cross-section:



»BLOCK« | »BLOCK«

– Jedes Band ist ein Unikat –
Die Patina des Vintageleders kann
stark unterschiedlich ausfallen.

– Every watch strap is unique –
The patina of the vintage leather
can strongly vary.

Mod. 172 | Jersey

DE: *Echt Vintageleder* |

Naht: *Ton in Ton* | Bandstärke: *ca. 4,0 mm auf 4,0 mm*

ENG: *Genuine Vintage Leather* |

Seam: *matching stitching* | Thickness of strap: *approx. 4.0 mm to 4.0 mm*



172 **03**
steingrau
stone grey

172 **05**
mahagoni
mahogany

172 **06**
cognac
cognac

172 **07**
mokka
mocha

172 **13**
schwarz
black



– Lieferung OHNE Schließe –
Bitte wählen Sie auf den
Seiten 182/183



– Supplied WITHOUT clasp –
Please select a clasp on
pages 182/183

Länge Length (mm)		M	
		114	82
Breite Width			
Anstoß / Lug	Schließe / Buckle		
20 mm	20 mm	●	
22 mm	22 mm	▲	
24 mm	22 mm	◐	
24 mm	24 mm	◑	

Form Querschnitt | Cross-section:



»BLOCK« | »BLOCK«

Mod. 169 | Hawker

DE: *Echt Rindsleder »Camouflage«* |

Naht: *Cremeweiß* | Bandstärke: *ca. 4,0 mm auf 4,0 mm*

ENG: *Genuine Cow Leather »Camouflage«* |

Seam: *cream white* | Thickness of strap: *approx. 4.0 mm to 4.0 mm*



169 **02**
sand
sand

169 **03**
steingrau
stone grey

169 **15**
natogrün
drab olive

169 **20**
marineblau
navy



– Lieferung OHNE Schließe –
Bitte wählen Sie auf den
Seiten 182 / 183



– Supplied WITHOUT clasp –
Please select a clasp on
pages 182 / 183

Länge Length (mm)		M	
		114	82
Breite Width			
Anstoß / Lug	Schließe / Buckle		
20 mm	20 mm	●	
22 mm	22 mm	▲	
24 mm	22 mm	◐	
24 mm	24 mm	◑	

Form Querschnitt | Cross-section:



»BLOCK« | »BLOCK«

Mod. 168 | Douglas

DE: *Echt Rindsleder »Camouflage«* |
Naht: *Ton in Ton* | *Bandstärke: ca. 4,0 mm auf 4,0 mm*
ENG: *Genuine Cow Leather »Camouflage«* |
Seam: *matching stitching* | *Thickness of strap: approx. 4.0 mm to 4.0 mm*



168 02 sand
168 03 steingrau / stone grey
168 15 natogrün / drab olive
168 20 marineblau / navy



– Lieferung OHNE Schließe –
Bitte wählen Sie auf den
Seiten 182 / 183



– Supplied WITHOUT clasp –
Please select a clasp on
pages 182 / 183

Länge Length (mm)		M	
		114	82
Breite Width			
Anstoß / Lug	Schließe / Buckle		
22 mm	20 mm	▲	
22 mm	22 mm	▲	
24 mm	22 mm	◐	
24 mm	24 mm	◑	

Form Querschnitt | Cross-section:



»BLOCK« | »BLOCK«

RIOS1931 Handnaht
Von innen vernäht!

RIOS1931 Saddler's Seam
Sewed from inside!

Mod. 167 | Grand

DE: *Echt Rindsleder »Camouflage«* | *»Handnaht«* |
Naht: *Cremeweiß* | *Bandstärke: ca. 4,0 mm auf 4,0 mm*
ENG: *Genuine Cow Leather »Camouflage«* | *»Saddler's Seam (Hand Seam)«* |
Seam: *cream white* | *Thickness of strap: approx. 4.0 mm to 4.0 mm*



167 03 steingrau / stone grey
167 15 natogrün / drab olive
167 Rückseiten / Reverse sides



– Lieferung OHNE SchlieÙe –
Bitte wahlen Sie auf den
Seiten 182/183



– Supplied WITHOUT clasp –
Please select a clasp on
pages 182/183

Lange Length (mm)		M	
		114	82
Breite Width			
AnstoÙ / Lug	SchlieÙe / Buckle		
22 mm	20 mm	▲	
22 mm	22 mm	▲	
24 mm	22 mm	◐	
24 mm	24 mm	◐	

Form Querschnitt | Cross-section:



»BLOCK« | »BLOCK«

RIOS1931 Handnaht
Von innen vernah!t!

RIOS1931 Saddler's Seam
Sewed from inside!

– Jedes Band ist ein Unikat –
Die Patina des Vintageleders kann
stark unterschiedlich ausfallen.

– Every watch strap is unique –
The patina of the vintage leather
can strongly vary.

Mod. 165 | Moore

DE: Echt Rindsleder | »Handnaht« |
Naht: Cremeweiß | Bandstarke: ca. 4,0 mm auf 4,0 mm
ENG: Genuine Cow Leather | »Saddler's Seam (Hand Seam)« |
Seam: cream white | Thickness of strap: approx. 4.0 mm to 4.0 mm



165 05
mahagoni
mahogany



165 06
cognac
cognac



165 07
mokka
mocha



165 13
schwarz
black



165
Ruckseiten
Reverse sides



Mod. 163 | Baxter

DE: Echt Rindsleder »Camouflage« | »Handnaht« |
Naht: Cremeweiß | Bandstarke: ca. 4,0 mm auf 4,0 mm
ENG: Genuine Cow Leather »Camouflage« | »Saddler's Seam (Hand Seam)« |
Seam: cream white | Thickness of strap: approx. 4.0 mm to 4.0 mm



163 03
steingrau
stone grey



163 15
natogrun
drab olive



163
Ruckseiten
Reverse sides

Lange Length (mm)		M	
		114	82
Breite Width			
AnstoÙ / Lug	SchlieÙe / Buckle		
18 mm	16 mm	●	
20 mm	16 mm	●	
20 mm	18 mm	●	
22 mm	18 mm	▲	

Form Querschnitt | Cross-section:



»BLOCK« | »BLOCK«

RIOS1931 Handnaht
Von innen vernah!t!

RIOS1931 Saddler's Seam
Sewed from inside!



Mod. 161 | Watts

DE: *Echt Rindsleder* | »Handnaht« |
 Naht: *Cremeweiß* | Bandstärke: *ca. 4,0mm auf 4,0mm*
 ENG: *Genuine Cow Leather* | »Saddler's Seam (Hand Seam)« |
 Seam: *cream white* | Thickness of strap: *approx. 4.0mm to 4.0mm*

Länge Length (mm)		M	
		114	82
Breite Width			
Anstoß / Lug	Schließe / Buckle		
18 mm	16 mm	●	
20 mm	16 mm	●	
20 mm	18 mm	●	
22 mm	18 mm	▲	

Form Querschnitt | Cross-section:



»BLOCK« | »BLOCK«

RIOS1931 Handnaht
Von innen vernäht!

RIOS1931 Saddler's Seam
Sewed from inside!

- Jedes Band ist ein Unikat – Die Patina des Vintageleders kann stark unterschiedlich ausfallen.
- Every watch strap is unique – The patina of the vintage leather can strongly vary.



161 **05** mahagoni mahogany
 161 **06** cognac cognac
 161 **07** mokka mocha
 161 **13** schwarz black



161 Rückseiten Reverse sides



Mod. 160 | Sullivan

DE: *Echt Vintageleder* | »Handnaht« |
 Naht: *Schwarz* | Bandstärke: *ca. 4,0mm auf 4,0mm*
 ENG: *Genuine Vintage Leather* | »Saddler's Seam (Hand Seam)« |
 Seam: *black* | Thickness of strap: *approx. 4.0mm to 4.0mm*

- Lieferung OHNE Schließe – Bitte wählen Sie auf den Seiten 182 / 183



- Supplied WITHOUT clasp – Please select a clasp on pages 182 / 183

Länge Length (mm)		M	
		114	82
Breite Width			
Anstoß / Lug	Schließe / Buckle		
20 mm	20 mm	●	
22 mm	22 mm	▲	
24 mm	24 mm	◐	

Form Querschnitt | Cross-section:



»BLOCK« | »BLOCK«

RIOS1931 Handnaht
Von innen vernäht!

RIOS1931 Saddler's Seam
Sewed from inside!

- Jedes Band ist ein Unikat – Die Patina des Vintageleders kann stark unterschiedlich ausfallen.
- Every watch strap is unique – The patina of the vintage leather can strongly vary.



160 **03** steingrau stone grey
 160 **04** honig honey
 160 **05** mahagoni mahogany
 160 **06** cognac cognac
 160 **07** mokka mocha
 160 **13** schwarz black



160 Rückseiten Reverse sides



Mit Einziehfarbe
With Leather Dye



Mod. 159 | Bedford

DE: *Echt Vintageleder* | »Handnaht« |
Naht: *Cremeweiß* | Bandstärke: *ca. 2,7mm auf 2,7mm*
ENG: *Genuine Vintage Leather* | »Saddler's Seam (Hand Seam)« |
Seam: *cream white* | Thickness of strap: *approx. 2.7mm to 2.7mm*



159 **03** steingrau / stone grey
159 **04** honig / honey
159 **05** mahagoni / mahogany
159 **06** cognac / cognac
159 **07** mokka / mocha
159 **13** schwarz / black



159
Rückseiten
Reverse sides

Länge Length (mm)		M	
		114	82
Breite Width			
Anstoß / Lug	Schleße / Buckle		
18 mm	16 mm	●	
19 mm	16 mm	●	
20 mm	16 mm	●	
22 mm	18 mm	▲	

Form Querschnitt | Cross-section:



»BLOCK« | »BLOCK«

RIOS1931 Handnaht
Von innen vernäht!

RIOS1931 Saddler's Seam
Sewed from inside!

- Jedes Band ist ein Unikat – Die Patina des Vintageleders kann stark unterschiedlich ausfallen.
- Every watch strap is unique – The patina of the vintage leather can strongly vary.



Mit Einziehfarbe
With Leather Dye



Mod. 158 | Walker

DE: *Echt Vintageleder* | »Handnaht« |
Naht: *Schwarz* | Bandstärke: *ca. 2,7mm auf 2,7mm*
ENG: *Genuine Vintage Leather* | »Saddler's Seam (Hand Seam)« |
Seam: *black* | Thickness of strap: *approx. 2.7mm to 2.7mm*



158 **03** steingrau / stone grey
158 **04** honig / honey
158 **05** mahagoni / mahogany
158 **06** cognac / cognac
158 **07** mokka / mocha
158 **13** schwarz / black



158
Rückseiten
Reverse sides

Länge Length (mm)		M	
		114	82
Breite Width			
Anstoß / Lug	Schleße / Buckle		
18 mm	16 mm	●	
19 mm	16 mm	●	
20 mm	16 mm	●	
22 mm	18 mm	▲	

Form Querschnitt | Cross-section:



»BLOCK« | »BLOCK«

RIOS1931 Handnaht
Von innen vernäht!

RIOS1931 Saddler's Seam
Sewed from inside!

- Jedes Band ist ein Unikat – Die Patina des Vintageleders kann stark unterschiedlich ausfallen.
- Every watch strap is unique – The patina of the vintage leather can strongly vary.



Mit Kantenlack
With Edge Colour



Mod. 157 | **Harrison**

DE: *Echt Vintageleder* | »Handnaht« |
Naht: *Cremeweiß* | Bandstärke: *ca. 2,7mm auf 2,7mm*
ENG: *Genuine Vintage Leather* | »Saddler's Seam (Hand Seam)« |
Seam: *cream white* | Thickness of strap: *approx. 2.7mm to 2.7mm*



157 03 steingrau stone grey
157 04 honig honey
157 05 mahagoni mahogany
157 06 cognac cognac
157 07 mokka mocha
157 13 schwarz black



Länge Length (mm)		M	
		114	82
Breite Width			
Anstoß / Lug	Schließe / Buckle		
18 mm	16 mm	●	
19 mm	16 mm	●	
20 mm	16 mm	●	
22 mm	18 mm	▲	

Form Querschnitt | Cross-section:



»BLOCK« | »BLOCK«

RIOS1931 Handnaht
Von innen vernäht!

RIOS1931 Saddler's Seam
Sewed from inside!

- Jedes Band ist ein Unikat -
Die Patina des Vintageleders kann stark unterschiedlich ausfallen.
- Every watch strap is unique -
The patina of the vintage leather can strongly vary.

157 Rückseiten
Reverse sides



Mit Einziehfarbe
With Leather Dye



Mod. 155 | **Hudson**

DE: *Echt Velourleder* | »Handnaht« |
Naht: *Cremeweiß* | Bandstärke: *ca. 2,7mm auf 2,7mm*
ENG: *Genuine Suede* | »Saddler's Seam (Hand Seam)« |
Seam: *cream white* | Thickness of strap: *approx. 2.7 mm to 2.7 mm*



155 03 steingrau stone grey
155 06 cognac cognac
155 07 mokka mocha
155 13 schwarz black

Länge Length (mm)		M	
		114	82
Breite Width			
Anstoß / Lug	Schließe / Buckle		
18 mm	16 mm	●	
19 mm	16 mm	●	
20 mm	16 mm	●	
22 mm	18 mm	▲	

Form Querschnitt | Cross-section:



»BLOCK« | »BLOCK«

RIOS1931 Handnaht
Von innen vernäht!

RIOS1931 Saddler's Seam
Sewed from inside!



Länge Length (mm)		M	
		114	82
Breite Width			
Anstoß / Lug	Schließe / Buckle		
18 mm	16 mm	●	
20 mm	16 mm	●	
22 mm	18 mm	▲	

Form Querschnitt | Cross-section:



»BLOCK« | »BLOCK«

Mod. **152** | **Franklin**

DE: *Echt Velourleder* |

Naht: *Ton in Ton* | Bandstärke: *ca. 3,5 mm auf 3,0 mm*

ENG: *Genuine Suede* |

Seam: *matching stitching* | *Thickness of strap: approx. 3.5 mm to 3.0 mm*



152 **03**
steingrau
stone grey

152 **06**
cognac
cognac

152 **07**
mokka
mocha

152 **13**
schwarz
black



Länge Length (mm)		M	
		114	82
Breite Width			
Anstoß / Lug	Schließe / Buckle		
18 mm	16 mm	●	
19 mm	16 mm	●	
20 mm	18 mm	●	

Form Querschnitt | Cross-section:



»ECKIG« | »SQUARE«

Mod. **150** | **Tompson**

DE: *Echt Velourleder* |

Naht: *Ton in Ton* | Bandstärke: *ca. 3,5 mm auf 3,0 mm*

ENG: *Genuine Suede* |

Seam: *matching stitching* | *Thickness of strap: approx. 3.5 mm to 3.0 mm*



150 **03**
steingrau
stone grey

150 **06**
cognac
cognac

150 **07**
mokka
mocha

150 **13**
schwarz
black

Seite | Page 120
Mod. 158

Seite | Page 122
Mod. 150

Seite | Page 122
Mod. 150

Seite | Page 120
Mod. 159

Wasserresistent

Water resistant



Seite | Page 126
Mod. 147



Länge Length (mm)		M	
		114 82	
Breite Width			
Anstoß / Lug	Schließe / Buckle		
18 mm	16 mm	●	
20 mm	18 mm	●	
22 mm	20 mm	▲	

Form Querschnitt | Cross-section:



»RUND« | »ROUND«

Mod. 149 | **Speed**

DE: Alligatorennarbung auf echt Rindsleder geprägt mit Kautschukgriff | »Wasserresistent« | »Art Manuel« | Naht: Rot | Bandstärke: ca. 6,0mm auf 3,0mm

ENG: Embossed Alligator Grain on Genuine Cow Leather with rubber grip | »Water resistant« | »Art Manuel« | Seam: red | Thickness of strap: approx. 6.0mm to 3.0mm



149 13
schwarz
black



149
Rückseiten
Reverse sides



Länge Length (mm)		M	
		114 82	
Breite Width			
Anstoß / Lug	Schließe / Buckle		
18 mm	16 mm	●	
20 mm	18 mm	●	
22 mm	20 mm	▲	

Form Querschnitt | Cross-section:



»RUND« | »ROUND«

Mod. 148 | **Power**

DE: Alligatorennarbung auf echt Rindsleder geprägt mit Kautschukgriff | »Wasserresistent« | »Art Manuel« | Naht: Ton in Ton | Bandstärke: ca. 6,0mm auf 3,0mm

ENG: Embossed Alligator Grain on Genuine Cow Leather with rubber grip | »Water resistant« | »Art Manuel« | Seam: matching stitching | Thickness of strap: approx. 6.0mm to 3.0mm



148 13
schwarz
black



148
Rückseiten
Reverse sides



Mod. 147 | **Polo**

DE: *Echt Rindsleder mit Kautschukgriff* | »Wasserresistent« | »Art Manuel« |
 Naht: *Cremeweiß* | *Bandstärke: ca. 6,0mm auf 3,0mm*

ENG: *Genuine Cow Leather with rubber grip* | »Water resistant« | »Art Manuel« |
 Seam: *cream white* | *Thickness of strap: approx. 6.0mm to 3.0mm*



147 13
schwarz
black

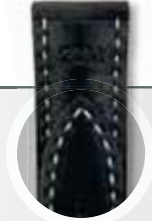

147
Rückseiten
Reverse sides

Länge Length (mm)		M	
		114 82	
Breite Width			
Anstoß / Lug	Schließe / Buckle		
18 mm	16 mm	●	
20 mm	18 mm	●	
22 mm	18 mm	▲	

Form Querschnitt | Cross-section:



»RUND« | »ROUND«



Mod. 146 | **Sunset**

DE: *Echt Rindsleder mit Kautschukgriff* | »Wasserresistent« | »Art Manuel« |
 Naht: *Ton in Ton* | *Bandstärke: ca. 6,0mm auf 3,0mm*

ENG: *Genuine Cow Leather with rubber grip* | »Water resistant« | »Art Manuel« |
 Seam: *matching stitching* | *Thickness of strap: approx. 6.0mm to 3.0mm*



146 13
schwarz
black



146
Rückseiten
Reverse sides

Länge Length (mm)		M	
		114 82	
Breite Width			
Anstoß / Lug	Schließe / Buckle		
18 mm	16 mm	●	
20 mm	18 mm	●	
22 mm	18 mm	▲	

Form Querschnitt | Cross-section:



»RUND« | »ROUND«



Mod. 144 | Richmond

DE: *Silikon* | *FaltschlieÙe* | »Wasserresistent« |
 Naht: *Ohne* | *Bandstärke: ca. 3,5 mm auf 3,5 mm*
 ENG: *Silicon* | *Folding buckle* | »Water resistant« |
 Seam: *no stitching* | *Thickness of strap: approx. 3.5 mm to 3.5 mm*



144 13
 schwarz
 black

Länge Length (mm)		M	
		85 85	
Breite Width			
AnstoÙ / Lug	SchlieÙe / Buckle		
18 mm	18 mm	●	
20 mm	20 mm	●	
22 mm	22 mm	▲	

Form Querschnitt | Cross-section:



»BLOCK« | »BLOCK«



Mod. 142 | Kansas

DE: *Silikon* | »Wasserresistent« |
 Naht: *Ohne* | *Bandstärke: ca. 5,0 mm auf 4,0 mm*
 ENG: *Silicon* | »Water resistant« |
 Seam: *no stitching* | *Thickness of strap: approx. 5.0 mm to 4.0 mm*



142 13
 schwarz
 black

Länge Length (mm)		M	
		130 74	
Breite Width			
AnstoÙ / Lug	SchlieÙe / Buckle		
20 mm	18 mm	●	
22 mm	20 mm	▲	
24 mm	22 mm	◐	

Form Querschnitt | Cross-section:



»LEICHT RUND« | »LIGHT ROUND«



Mod. 140 Atlanta

DE: Silikon | »Wasserresistent« |
 Naht: Ohne | Bandstärke: ca. 2,5 mm auf 2,5 mm
 ENG: Silicon | »Water resistant« |
 Seam: no stitching | Thickness of strap: approx. 2.5 mm to 2.5 mm



140 13
 schwarz
 black

Länge Length (mm)		M	
		120 75	
Breite Width			
Anstoß / Lug	Schließe / Buckle		
18 mm	18 mm	●	
20 mm	20 mm	●	

Form Querschnitt | Cross-section:



»BLOCK« | »BLOCK«



Mod. 134 Bass

DE: Hightechmaterial Nytech | »Wasserresistent« | »Art Manuel« |
 Naht: Cremeweiß | Bandstärke: ca. 7,0 mm auf 3,0 mm
 ENG: Hightech Material Nytech | »Water resistant« | »Art Manuel« |
 Seam: cream white | Thickness of strap: approx. 7.0 mm to 3.0 mm

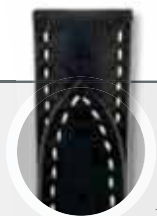

134 13
 schwarz
 black

134
 Rückseiten
 Reverse sides

Länge Length (mm)		M	
		114 82	
Breite Width			
Anstoß / Lug	Schließe / Buckle		
18 mm	16 mm	●	
20 mm	18 mm	●	
22 mm	20 mm	▲	
24 mm	22 mm	◐	

Form Querschnitt | Cross-section:



»RUND« | »ROUND«



Länge Length (mm)		M	
		114	82
Breite Width			
Anstoß / Lug	Schließe / Buckle		
18 mm	16 mm	●	
20 mm	18 mm	●	
22 mm	20 mm	▲	
24 mm	22 mm	◐	

Form Querschnitt | Cross-section:



»RUND« | »ROUND«

Mod. 133 Just

DE: Hightechmaterial Nytech | »Wasserresistent« | »Art Manuel« |

Naht: Ton in Ton | Bandstärke: ca. 7,0 mm auf 3,0 mm

ENG: Hightech Material Nytech | »Water resistant« | »Art Manuel« |

Seam: matching stitching | Thickness of strap: approx. 7.0 mm to 3.0 mm



133 13
schwarz
black



133
Rückseiten
Reverse sides



Länge Length (mm)		M	
		114	82
Breite Width			
Anstoß / Lug	Schließe / Buckle		
18 mm	16 mm	●	
20 mm	18 mm	●	
22 mm	20 mm	▲	
24 mm	22 mm	◐	

Form Querschnitt | Cross-section:



»ECKIG« | »SQUARE«

Mod. 132 Advance

DE: Hightechmaterial Nytech | Futter mit Kautschukgriff | »Wasserresistent« | »Art Manuel« |

Naht: Ton in Ton | Bandstärke: ca. 4,0 mm auf 3,5 mm

ENG: Hightech Material Nytech | Inner lining with rubber grip | »Water resistant« | »Art Manuel« |

Seam: matching stitching | Thickness of strap: approx. 4.0 mm to 3.5 mm



132 13
schwarz
black



132
Rückseiten
Reverse sides



Mod. 131 Next

DE: Hightechmaterial Ballistic | »Wasserresistent« | »Art Manuel« |
Naht: Cremeweiß | Bandstärke: ca. 6,0mm auf 3,0mm

ENG: Hightech Material Ballistic | »Water resistant« | »Art Manuel« |
Seam: cream white | Thickness of strap: approx. 6.0mm to 3.0mm

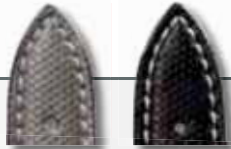

131 03
steingrau
stone grey

131 13
schwarz
black



131
Rückseiten
Reverse sides

Länge Length (mm)		M	
		114 82	
Breite Width			
Anstoß / Lug	Schließe / Buckle		
18 mm	16 mm	●	
20 mm	18 mm	●	
22 mm	18 mm	▲	

Form Querschnitt | Cross-section:



»RUND« | »ROUND«



Mod. 130 Activity

DE: Hightechmaterial Dynamic | »Wasserresistent« | »Art Manuel« |
Naht: Ton in Ton | Bandstärke: ca. 3,5mm auf 3,0mm

ENG: Hightech Material Dynamic | »Water resistant« | »Art Manuel« |
Seam: matching stitching | Thickness of strap: approx. 3.5mm to 3.0mm



130 13
schwarz
black



130
Rückseiten
Reverse sides

Länge Length (mm)		M	
		114 82	
Breite Width			
Anstoß / Lug	Schließe / Buckle		
18 mm	16 mm	●	
20 mm	18 mm	●	
22 mm	20 mm	▲	
24 mm	22 mm	◐	

Form Querschnitt | Cross-section:



»ECKIG« | »SQUARE«



Mod. 119 | Dive

DE: *Echt Rindsleder (Hydrophobiert) | »Wasserresistent«* |
 Naht: *Cremeweiß* | *Bandstärke: ca. 3,5 mm auf 3,5 mm*

ENG: *Genuine Cow Leather (Hydrophobicity) | »Water resistant«* |
 Seam: *cream white* | *Thickness of strap: approx. 3.5 mm to 3.5 mm*

Länge Length (mm)		M	
		114 82	
Breite Width			
Anstoß / Lug	Schließe / Buckle		
18 mm	16 mm	●	
20 mm	18 mm	●	
22 mm	20 mm	▲	

Form Querschnitt | Cross-section:



119 **05**
mahagony
mahogany

119 **07**
mokka
mocha

119 **13**
schwarz
black

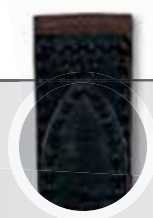

119
Rückseiten
Reverse sides



Mod. 118 | Scuba

DE: *Echt Rindsleder (Hydrophobiert) | »Wasserresistent«* |
 Naht: *Ton in Ton* | *Bandstärke: ca. 3,5 mm auf 3,5 mm*

ENG: *Genuine Cow Leather (Hydrophobicity) | »Water resistant«* |
 Seam: *matching stitching* | *Thickness of strap: approx. 3.5 mm to 3.5 mm*

Länge Length (mm)		M	
		114 82	
Breite Width			
Anstoß / Lug	Schließe / Buckle		
18 mm	16 mm	●	
20 mm	18 mm	●	
22 mm	20 mm	▲	

Form Querschnitt | Cross-section:



118 **05**
mahagony
mahogany

118 **07**
mokka
mocha

118 **13**
schwarz
black



118
Rückseiten
Reverse sides



Mod. 117 | **Deep Sea**

DE: *Echt Rindsleder (Hydrophobiert) | »Wasserresistent«* |
 Naht: *Cremeweiß | Bandstärke: ca. 5,0mm auf 3,0mm*
 ENG: *Genuine Cow Leather (Hydrophobicity) | »Water resistant«* |
 Seam: *cream white | Thickness of strap: approx. 5.0mm to 3.0mm*



117 **05**
mahagoni
mahogany

117 **07**
mokka
mocha

117 **13**
schwarz
black



117
Rückseiten
Reverse sides

Länge Length (mm)		M	
		114 82	
Breite Width			
Anstoß / Lug	Schließe / Buckle		
18 mm	16 mm	●	
20 mm	18 mm	●	
22 mm	20 mm	▲	

Form Querschnitt | Cross-section:



»ECKIG« | »SQUARE«



Mod. 116 | **Off Shore**

DE: *Echt Rindsleder (Hydrophobiert) | »Wasserresistent«* |
 Naht: *Ton in Ton | Bandstärke: ca. 5,0mm auf 3,0mm*
 ENG: *Genuine Cow Leather (Hydrophobicity) | »Water resistant«* |
 Seam: *matching stitching | Thickness of strap: approx. 5.0mm to 3.0mm*



116 **05**
mahagoni
mahogany

116 **07**
mokka
mocha

116 **13**
schwarz
black



116
Rückseiten
Reverse sides

Länge Length (mm)		M	
		114 82	
Breite Width			
Anstoß / Lug	Schließe / Buckle		
18 mm	16 mm	●	
20 mm	18 mm	●	
22 mm	20 mm	▲	

Form Querschnitt | Cross-section:



»ECKIG« | »SQUARE«



Seite | Page 128
Mod. 134

Nato- / Durchzugsbänder

Nato Straps / One-Piece Straps

Seite | Page 138
Mod. 490

Seite | Page 142
Mod. 483

Seite | Page 136
Mod. 495



Länge Length (mm)		M	
		290	110
Breite Width			
Anstoß / Lug	Schließe / Buckle		
18 mm	18 mm	●	
20 mm	20 mm	●	
22 mm	22 mm	▲	
24 mm	24 mm	◐	

Form Querschnitt | Cross-section:



»BLOCK« | »BLOCK«

Mod. 498 | **Nato Bratislava**

DE: *Echt Shell Cordovan Leder* | *Schließe und Schlaufen in glanz* | *Naht: Ton in Ton* | *Bandstärke: ca. 1,6mm auf 1,6mm*

ENG: *Genuine Shell Cordovan Leather* | *Buckle and loops, glossy finish* | *Seam: matching stitching* | *Thickness of strap: approx. 1.6mm to 1.6mm*



498 **04**
honig
honey

498 **06**
cognac
cognac

498 **07**
mokka
mocha

498 **13**
schwarz
black



DE: *Schließe und Schlaufen in glanz*
ENG: *Buckle and loops, glossy finish*



Länge Length (mm)		M	
		290	110
Breite Width			
Anstoß / Lug	Schließe / Buckle		
18 mm	18 mm	●	
20 mm	20 mm	●	
22 mm	22 mm	▲	
24 mm	24 mm	◐	

Form Querschnitt | Cross-section:



»BLOCK« | »BLOCK«

Mod. 497 | **Nato Prague**

DE: *Echt Shell Cordovan Leder* | *Schließe und Schlaufen gebürstet* | *Naht: Ton in Ton* | *Bandstärke: ca. 1,6mm auf 1,6mm*

ENG: *Genuine Shell Cordovan Leather* | *Buckle and loops brushed* | *Seam: matching stitching* | *Thickness of strap: approx. 1.6mm to 1.6mm*



497 **04**
honig
honey

497 **06**
cognac
cognac

497 **07**
mokka
mocha

497 **13**
schwarz
black



DE: *Schließe und Schlaufen gebürstet*
ENG: *Buckle and loops brushed*



Länge Length (mm)		M	
		290	110
Breite Width			
Anstoß / Lug	Schließe / Buckle		
18 mm	18 mm	●	
20 mm	20 mm	●	
22 mm	22 mm	▲	
24 mm	24 mm	◐	

Form Querschnitt | Cross-section:



»BLOCK« | »BLOCK«

Mod. 496 | **Nato Budapest**

DE: *Echt Shell Cordovan Leder* | Schließe und Schlaufen schwarz, in matt | Naht: *Ton in Ton* | Bandstärke: *ca. 1,6mm auf 1,6mm*

ENG: *Genuine Shell Cordovan Leather* | Buckle and loops black, matt finish | Seam: *matching stitching* | Thickness of strap: *approx. 1.6mm to 1.6mm*



496 **04**
honig
honey

496 **06**
cognac
cognac

496 **07**
mokka
mocha

496 **13**
schwarz
black



DE: Schließe und Schlaufen schwarz, in matt
ENG: Buckle and loops black, matt finish

Mod. 495 | **Nato Sofia**

DE: *Echt Canvas* | Schließe und Schlaufen in glanz | Naht: *Ton in Ton* | Bandstärke: *ca. 1,6mm auf 1,6mm*

ENG: *Genuine Canvas* | Buckle and loops, glossy finish | Seam: *matching stitching* | Thickness of strap: *approx. 1.6mm to 1.6mm*



495 **03**
steingrau
stone grey

495 **04**
honig
honey

495 **06**
cognac
cognac

495 **07**
mokka
mocha

495 **13**
schwarz
black

495 **15**
natogrün
drab olive

Länge Length (mm)		M	
		290	110
Breite Width			
Anstoß / Lug	Schließe / Buckle		
18 mm	18 mm	●	
20 mm	20 mm	●	
22 mm	22 mm	▲	
24 mm	24 mm	◐	

Form Querschnitt | Cross-section:



»BLOCK« | »BLOCK«

Dieses Band bekommt durch das Tragen einen
– Used-Look –

Wearing this strap will give it a
– used look –



DE: Schließe und Schlaufen in glanz
ENG: Buckle and loops, glossy finish



Mod. 494 | **Nato Warsaw**

DE: *Echt Canvas* | *Schließe und Schlaufen gebürstet* |
Naht: Ton in Ton | *Bandstärke: ca. 1,6 mm auf 1,6 mm*

ENG: *Genuine Canvas* | *Buckle and loops brushed* |
Seam: matching stitching | *Thickness of strap: approx. 1.6 mm to 1.6 mm*



494 03 steingrau stone grey
 494 04 honig honey
 494 06 cognac cognac
 494 07 mokka mocha
 494 13 schwarz black
 494 15 natogrün drab olive

Länge Length (mm)		M	
		290	110
Breite Width			
Anstoß / Lug	Schließe / Buckle		
18 mm	18 mm	●	
20 mm	20 mm	●	
22 mm	22 mm	▲	
24 mm	24 mm	◐	

Form Querschnitt | Cross-section:



»BLOCK« | »BLOCK«

Dieses Band bekommt durch das Tragen einen
 – Used-Look –

Wearing this strap will give it a
 – used look –

DE: Schließe und Schlaufen gebürstet
 ENG: Buckle and loops brushed



Mod. 493 | **Nato Tallinn**

DE: *Echt Canvas* | *Schließe und Schlaufen schwarz, in matt* |
Naht: Ton in Ton | *Bandstärke: ca. 1,6 mm auf 1,6 mm*

ENG: *Genuine Canvas* | *Buckle and loops black, matt finish* |
Seam: matching stitching | *Thickness of strap: approx. 1.6 mm to 1.6 mm*



493 03 steingrau stone grey
 493 04 honig honey
 493 06 cognac cognac
 493 07 mokka mocha
 493 13 schwarz black
 493 15 natogrün drab olive

Länge Length (mm)		M	
		290	110
Breite Width			
Anstoß / Lug	Schließe / Buckle		
18 mm	18 mm	●	
20 mm	20 mm	●	
22 mm	22 mm	▲	
24 mm	24 mm	◐	

Form Querschnitt | Cross-section:



»BLOCK« | »BLOCK«

Dieses Band bekommt durch das Tragen einen
 – Used-Look –

Wearing this strap will give it a
 – used look –

DE: Schließe und Schlaufen schwarz, in matt
 ENG: Buckle and loops black, matt finish





Länge Length (mm)		M	
		290	110
Breite Width			
Anstoß / Lug	Schließe / Buckle		
18 mm	18 mm	●	
20 mm	20 mm	●	
22 mm	22 mm	▲	
24 mm	24 mm	◐	

Form Querschnitt | Cross-section:



»BLOCK« | »BLOCK«

– Jedes Band ist ein Unikat –
Die Patina des Vintageleders kann stark unterschiedlich ausfallen.

– Every watch strap is unique –
The patina of the vintage leather can strongly vary.

Mod. **491** | **Nato Amsterdam**

DE: *Echt Vintageleder | Schließe und Schlaufen in glanz | Naht: Ton in Ton | Bandstärke: ca. 1,6mm auf 1,6mm*

ENG: *Genuine Vintage Leather | Buckle and loops, glossy finish | Seam: matching stitching | Thickness of strap: approx. 1.6mm to 1.6mm*



491 **03** steingrau / stone grey
491 **04** honig / honey
491 **05** mahagoni / mahogany
491 **06** cognac / cognac
491 **07** mokka / mocha
491 **13** schwarz / black

DE: Schließe und Schlaufen **glanz**
ENG: Buckle and loops, **glossy finish**



Mod. **490** | **Nato Luxembourg**

DE: *Echt Vintageleder | Schließe und Schlaufen gebürstet | Naht: Ton in Ton | Bandstärke: ca. 1,6mm auf 1,6mm*

ENG: *Genuine Vintage Leather | Buckle and loops brushed | Seam: matching stitching | Thickness of strap: approx. 1.6mm to 1.6mm*



490 **03** steingrau / stone grey
490 **04** honig / honey
490 **05** mahagoni / mahogany
490 **06** cognac / cognac
490 **07** mokka / mocha
490 **13** schwarz / black

Länge Length (mm)		M	
		290	110
Breite Width			
Anstoß / Lug	Schließe / Buckle		
18 mm	18 mm	●	
20 mm	20 mm	●	
22 mm	22 mm	▲	
24 mm	24 mm	◐	

Form Querschnitt | Cross-section:



»BLOCK« | »BLOCK«

– Jedes Band ist ein Unikat –
Die Patina des Vintageleders kann stark unterschiedlich ausfallen.

– Every watch strap is unique –
The patina of the vintage leather can strongly vary.

DE: Schließe und Schlaufen **gebürstet**
ENG: Buckle and loops **brushed**





Mod. 489 | **Nato Riga**

DE: *Echt Vintageleder* | *Schließe und Schlaufen schwarz, in matt* |
Naht: Ton in Ton | *Bandstärke: ca. 1,6mm auf 1,6mm*

ENG: *Genuine Vintage Leather* | *Buckle and loops black, matt finish* |
Seam: matching stitching | *Thickness of strap: approx. 1.6mm to 1.6mm*



489 03 steingrau / stone grey
 489 04 honig / honey
 489 05 mahagoni / mahogany
 489 06 cognac / cognac
 489 07 mokka / mocha
 489 13 schwarz / black

Länge Length (mm)		M	
		290	110
Breite Width			
Anstoß / Lug	Schließe / Buckle		
18 mm	18 mm	●	
20 mm	20 mm	●	
22 mm	22 mm	▲	
24 mm	24 mm	◐	

Form Querschnitt | Cross-section:



»BLOCK« | »BLOCK«

- Jedes Band ist ein Unikat -
Die Patina des Vintageleders kann stark unterschiedlich ausfallen.
- Every watch strap is unique -
The patina of the vintage leather can strongly vary.



DE: Schließe und Schlaufen **schwarz, in matt**
 ENG: Buckle and loops **black, matt finish**



Mod. 488 | **Nato Brussels**

DE: *Echt Vintageleder* | *Schließe und Schlaufen in glanz* |
Naht: Cremeweiß | *Bandstärke: ca. 1,6mm auf 1,6mm*

ENG: *Genuine Vintage Leather* | *Buckle and loops, glossy finish* |
Seam: cream white | *Thickness of strap: approx. 1.6mm to 1.6mm*



488 03 steingrau / stone grey
 488 04 honig / honey
 488 05 mahagoni / mahogany
 488 06 cognac / cognac
 488 07 mokka / mocha
 488 13 schwarz / black

Länge Length (mm)		M	
		290	110
Breite Width			
Anstoß / Lug	Schließe / Buckle		
18 mm	18 mm	●	
20 mm	20 mm	●	
22 mm	22 mm	▲	
24 mm	24 mm	◐	

Form Querschnitt | Cross-section:



»BLOCK« | »BLOCK«

- Jedes Band ist ein Unikat -
Die Patina des Vintageleders kann stark unterschiedlich ausfallen.
- Every watch strap is unique -
The patina of the vintage leather can strongly vary.



DE: Schließe und Schlaufen **glanz**
 ENG: Buckle and loops, **glossy finish**



Länge Length (mm)		M	
		290	110
Breite Width			
Anstoß / Lug	Schließe / Buckle		
18 mm	18 mm	●	
20 mm	20 mm	●	
22 mm	22 mm	▲	
24 mm	24 mm	◐	

Form Querschnitt | Cross-section:



»BLOCK« | »BLOCK«

– Jedes Band ist ein Unikat –
Die Patina des Vintageleders kann stark unterschiedlich ausfallen.

– Every watch strap is unique –
The patina of the vintage leather can strongly vary.

Mod. 487 | **Nato Copenhagen**

DE: *Echt Vintageleder | Schließe und Schlaufen gebürstet | Naht: Cremeweiß | Bandstärke: ca. 1,6 mm auf 1,6 mm*

ENG: *Genuine Vintage Leather | Buckle and loops brushed | Seam: cream white | Thickness of strap: approx. 1.6 mm to 1.6 mm*



487 **03** steingrau
stone grey

487 **04** honig
honey

487 **05** mahagoni
mahogany

487 **06** cognac
cognac

487 **07** mokka
mocha

487 **13** schwarz
black

DE: Schließe und Schlaufen gebürstet
ENG: Buckle and loops brushed



Länge Length (mm)		M	
		290	110
Breite Width			
Anstoß / Lug	Schließe / Buckle		
18 mm	18 mm	●	
20 mm	20 mm	●	
22 mm	22 mm	▲	
24 mm	24 mm	◐	

Form Querschnitt | Cross-section:



»BLOCK« | »BLOCK«

– Jedes Band ist ein Unikat –
Die Patina des Vintageleders kann stark unterschiedlich ausfallen.

– Every watch strap is unique –
The patina of the vintage leather can strongly vary.

Mod. 486 | **Nato Oslo**

DE: *Echt Vintageleder | Schließe und Schlaufen schwarz, in matt | Naht: Cremeweiß | Bandstärke: ca. 1,6 mm auf 1,6 mm*

ENG: *Genuine Vintage Leather | Buckle and loops black, matt finish | Seam: cream white | Thickness of strap: approx. 1.6 mm to 1.6 mm*



486 **03** steingrau
stone grey

486 **04** honig
honey

486 **05** mahagoni
mahogany

486 **06** cognac
cognac

486 **07** mokka
mocha

486 **13** schwarz
black

DE: Schließe und Schlaufen schwarz, in matt
ENG: Buckle and loops black, matt finish



Länge Length (mm)		M	
		290	110
Breite Width			
Anstoß / Lug	Schließe / Buckle		
18 mm	18 mm	●	
20 mm	20 mm	●	
22 mm	22 mm	▲	
24 mm	24 mm	◐	

Form Querschnitt | Cross-section:



»BLOCK« | »BLOCK«

Mod. 485 | **Nato Athens**

DE: *Echt Kalbsleder* | Schließe und Schlaufen in glanz |
Naht: *Ton in Ton* | Bandstärke: *ca. 1,6 mm auf 1,6 mm*

ENG: *Genuine Calfskin* | Buckle and loops, glossy finish |
Seam: *matching stitching* | Thickness of strap: *approx. 1.6 mm to 1.6 mm*

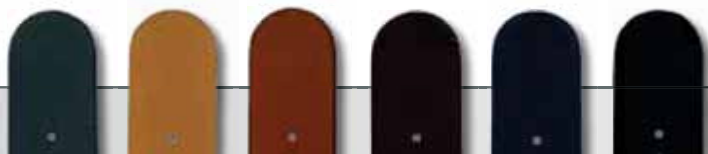

- 485 03
steingrau
stone grey
- 485 04
honig
honey
- 485 06
cognac
cognac
- 485 07
mokka
mocha
- 485 12
ozeanblau
ocean blue
- 485 13
schwarz
black



DE: Schließe und Schlaufen **glanz**
ENG: Buckle and loops, **glossy finish**



Länge Length (mm)		M	
		290	110
Breite Width			
Anstoß / Lug	Schließe / Buckle		
18 mm	18 mm	●	
20 mm	20 mm	●	
22 mm	22 mm	▲	
24 mm	24 mm	◐	

Form Querschnitt | Cross-section:



»BLOCK« | »BLOCK«

Mod. 484 | **Nato Lisbon**

DE: *Echt Kalbsleder* | Schließe und Schlaufen gebürstet |
Naht: *Ton in Ton* | Bandstärke: *ca. 1,6 mm auf 1,6 mm*

ENG: *Genuine Calfskin* | Buckle and loops brushed |
Seam: *matching stitching* | Thickness of strap: *approx. 1.6 mm to 1.6 mm*

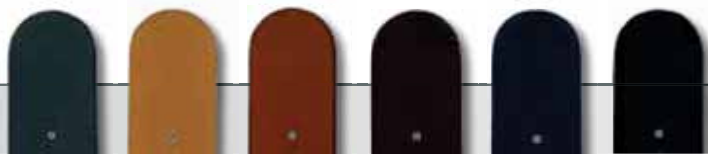

- 484 03
steingrau
stone grey
- 484 04
honig
honey
- 484 06
cognac
cognac
- 484 07
mokka
mocha
- 484 12
ozeanblau
ocean blue
- 484 13
schwarz
black



DE: Schließe und Schlaufen **gebürstet**
ENG: Buckle and loops **brushed**



Länge Length (mm)		M	
		290	110
Breite Width			
Anstoß / Lug	Schließe / Buckle		
18 mm	18 mm	●	
20 mm	20 mm	●	
22 mm	22 mm	▲	
24 mm	24 mm	◐	

Form Querschnitt | Cross-section:



»BLOCK« | »BLOCK«

Mod. **483** | **Nato Madrid**

DE: *Echt Kalbsleder* | *Schließe und Schlaufen schwarz, in matt* |
Naht: Ton in Ton | *Bandstärke: ca. 1,6 mm auf 1,6 mm*

ENG: *Genuine Calfskin* | *Buckle and loops black, matt finish* |
Seam: matching stitching | *Thickness of strap: approx. 1.6 mm to 1.6 mm*

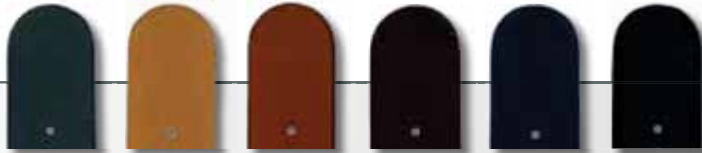

483 03
 steingrau
 stone grey

483 04
 honig
 honey

483 06
 cognac
 cognac

483 07
 mokka
 mocha

483 12
 ozeanblau
 ocean blue

483 13
 schwarz
 black

DE: *Schließe und Schlaufen schwarz, in matt*
 ENG: *Buckle and loops black, matt finish*



Länge Length (mm)		M	
		270	120
Breite Width			
Anstoß / Lug	Schließe / Buckle		
18 mm	18 mm	●	
20 mm	20 mm	●	
22 mm	22 mm	▲	

Form Querschnitt | Cross-section:



»BLOCK« | »BLOCK«

Mod. **481** | **Nato Ottawa**

DE: *Nylon* | *»Wasserresistent«* |
Naht: Ohne | *Bandstärke: ca. 1,0 mm auf 1,0 mm*

ENG: *Nylon* | *»Water resistant«* |
Seam: no stitching | *Thickness of strap: approx. 1.0 mm to 1.0 mm*



481 03
 steingrau
 stone grey

481 13
 schwarz
 black

481 15
 natogrün
 drab olive



Länge Length (mm)		M	
Breite Width		260	
Anstoß / Lug	Schließe / Buckle		
16 mm	16 mm	●	
18 mm	18 mm	●	
20 mm	20 mm	●	

Form Querschnitt | Cross-section:



»BLOCK« | »BLOCK«

Mod. 480 | Sailor

DE: Geflochtenes Perlon | »Wasserresistent« |
Naht: Ohne | Bandstärke: ca. 1,0mm auf 1,0mm

ENG: Plaited Perlon | »Water resistant« |
Seam: no stitching | Thickness of strap: approx. 1.0mm to 1.0mm



480 13
schwarz
black



Seite | Page 141
Mod. 485



Seite | Page 158
Mod. 380



*Seite | Page 161
Mod. 360*

*Seite | Page 162
Mod. 352*

Ersatzbänder Replacement Straps

RIOS1931

RIEMER OSWALD



Seite | Page 160
Mod. 363



– Technische Angabe –

*RIOS1931-Band, insbesondere
passend für Uhren der Marke
»Apple (Smartwatch)«*

Alle aufgeführten Firmen, Marken und
Kennzeichen sind Eigentum der jeweiligen
Hersteller, bzw. Markeninhaber und dienen
lediglich der Beschreibung.

151	Mod. 475	Messenger	<i>Echt zertifiziertes Bioleder</i>
151	Mod. 474	Online	<i>Echt zertifiziertes Bioleder</i>
152	Mod. 470	Stream	<i>Alligatorennarbung auf echt Rindsleder geprägt</i>
152	Mod. 464	Connect	<i>Echt Büffelleleder</i>
153	Mod. 460	Life	<i>Echt Vintageleder</i>



– Technische Angabe –

*RIOS1931-Band, insbesondere
passend für Uhren der Marke
»Omega«*

Alle aufgeführten Firmen, Marken und
Kennzeichen sind Eigentum der jeweiligen
Hersteller, bzw. Markeninhaber und dienen
lediglich der Beschreibung.

154	Mod. 396	Master	<i>Echt Alligatorenleder in matt, Fullcut</i>
154	Mod. 390	Engineer	<i>Echt Juchtenleder</i>



– Technische Angabe –

*RIOS1931-Band, insbesondere
passend für Uhren der Marke
»IWC«*

Alle aufgeführten Firmen, Marken und
Kennzeichen sind Eigentum der jeweiligen
Hersteller, bzw. Markeninhaber und dienen
lediglich der Beschreibung.

155	Mod. 389	Thunderbird	<i>Echt Alligatorenleder in matt, Fullcut</i>
155	Mod. 388	Spitfire	<i>Echt Alligatorenleder in matt, Fullcut</i>
156	Mod. 386	Hurricane	<i>Echt Alligatorenleder in matt, Fullcut</i>
156	Mod. 385	Typhoon	<i>Echt Büffelleleder</i>
157	Mod. 384	Blizzard	<i>Echt Kalbsleder</i>
157	Mod. 383	Scirocco	<i>Echt Kalbsleder</i>
158	Mod. 382	Albatros	<i>Hightechmaterial Nytech</i>



– Technical specification –

*RIOS1931 watch strap, particularly
suitable for watches of the brand
»Apple (Smart watches)«*

All the listed companies, brands and
symbols are the property of the respective
manufacturer and/or brand owners and are
for the descriptive purposes only.

151	Mod. 475	Messenger	<i>Genuine Certified Organic Leather</i>
151	Mod. 474	Online	<i>Genuine Certified Organic Leather</i>
152	Mod. 470	Stream	<i>Embossed Alligator Grain on Genuine Cow Leather</i>
152	Mod. 464	Connect	<i>Genuine Buffalo Leather</i>
153	Mod. 460	Life	<i>Genuine Vintage Leather</i>



– Technical specification –

*RIOS1931 watch strap, particularly
suitable for watches of the brand
»Omega«*

All the listed companies, brands and
symbols are the property of the respective
manufacturer and/or brand owners and are
for the descriptive purposes only.

154	Mod. 396	Master	<i>Genuine Alligator Leather, matt finish, fullcut</i>
154	Mod. 390	Engineer	<i>Genuine Russia Leather</i>



– Technical specification –

*RIOS1931 watch strap, particularly
suitable for watches of the brand
»IWC«*

All the listed companies, brands and
symbols are the property of the respective
manufacturer and/or brand owners and are
for the descriptive purposes only.

155	Mod. 389	Thunderbird	<i>Genuine Alligator Leather, matt finish, fullcut</i>
155	Mod. 388	Spitfire	<i>Genuine Alligator Leather, matt finish, fullcut</i>
156	Mod. 386	Hurricane	<i>Genuine Alligator Leather, matt finish, fullcut</i>
156	Mod. 385	Typhoon	<i>Genuine Buffalo Leather</i>
157	Mod. 384	Blizzard	<i>Genuine Calfskin</i>
157	Mod. 383	Scirocco	<i>Genuine Calfskin</i>
158	Mod. 382	Albatros	<i>Hightech Material Nytech</i>



– Technische Angabe –

RIOS1931-Band, insbesondere passend für Uhren der Marke »Bell & Ross«

Alle aufgeführten Firmen, Marken und Kennzeichen sind Eigentum der jeweiligen Hersteller, bzw. Markeninhaber und dienen lediglich der Beschreibung.

158 | Mod.380 | Copter

Echt Juchtenleder



– Technical specification –

RIOS1931 watch strap, particularly suitable for watches of the brand »Bell & Ross«

All the listed companies, brands and symbols are the property of the respective manufacturer and/or brand owners and are for the descriptive purposes only.

158 | Mod.380 | Copter

Genuine Russia Leather



– Technische Angabe –

RIOS1931-Band, insbesondere passend für Uhren der Marke Rolex Daytona«

Alle aufgeführten Firmen, Marken und Kennzeichen sind Eigentum der jeweiligen Hersteller, bzw. Markeninhaber und dienen lediglich der Beschreibung.

159 | Mod.371 | Prince

Echt Alligatorenleder in glanz, Fullcut



– Technical specification –

RIOS1931 watch strap, particularly suitable for watches of the brand »Rolex Daytona«

All the listed companies, brands and symbols are the property of the respective manufacturer and/or brand owners and are for the descriptive purposes only.

159 | Mod.371 | Prince

Genuine Alligator Leather, glossy finish, fullcut

159 | Mod.370 | King

Echt Alligatorenleder in matt, Fullcut

159 | Mod.370 | King

Genuine Alligator Leather, matt finish, fullcut



– Technische Angabe –

RIOS1931-Band, insbesondere passend für Uhren der Marke »Officine Panerai«

Alle aufgeführten Firmen, Marken und Kennzeichen sind Eigentum der jeweiligen Hersteller, bzw. Markeninhaber und dienen lediglich der Beschreibung.

160 | Mod.364 | Pisa

Echt Alligatorenleder in matt, Fullcut



– Technical specification –

RIOS1931 watch strap, particularly suitable for watches of the brand »Officine Panerai«

All the listed companies, brands and symbols are the property of the respective manufacturer and/or brand owners and are for the descriptive purposes only.

160 | Mod.364 | Pisa

Genuine Alligator Leather, matt finish, fullcut

160 | Mod.363 | Modena

Echt Alligatorenleder in matt, Fullcut

160 | Mod.363 | Modena

Genuine Alligator Leather, matt finish, fullcut

161 | Mod.361 | Milano

Echt Rindsleder (Hydrophobiert)

161 | Mod.361 | Milano

Genuine Cow Leather (Hydrophobicity)

161 | Mod.360 | Firenze

Echt Juchtenleder

161 | Mod.360 | Firenze

Genuine Russia Leather



– Technische Angabe –

RIOS1931-Band, insbesondere passend für Uhren der Marke »Cartier (Tank)«

Alle aufgeführten Firmen, Marken und Kennzeichen sind Eigentum der jeweiligen Hersteller, bzw. Markeninhaber und dienen lediglich der Beschreibung.

162 | Mod.352 | Louvre

Echt Alligatorenleder in matt, Fullcut



– Technical specification –

RIOS1931 watch strap, particularly suitable for watches of the brand »Cartier (Tank)«

All the listed companies, brands and symbols are the property of the respective manufacturer and/or brand owners and are for the descriptive purposes only.

162 | Mod.352 | Louvre

Genuine Alligator Leather, matt finish, fullcut



– Technische Angabe –

RIOS1931-Band, insbesondere passend für Uhren der Marke »Cartier (Pasha)«

Alle aufgeführten Firmen, Marken und Kennzeichen sind Eigentum der jeweiligen Hersteller, bzw. Markeninhaber und dienen lediglich der Beschreibung.

162 | Mod.350 | Versailles

Echt Alligatorenleder in matt, Fullcut



– Technical specification –

RIOS1931 watch strap, particularly suitable for watches of the brand »Cartier (Pasha)«

All the listed companies, brands and symbols are the property of the respective manufacturer and/or brand owners and are for the descriptive purposes only.

162 | Mod.350 | Versailles

Genuine Alligator Leather, matt finish, fullcut



– Technische Angabe –

RIOS1931-Band, insbesondere passend für Uhren der Marke »Patek Philippe«

Alle aufgeführten Firmen, Marken und Kennzeichen sind Eigentum der jeweiligen Hersteller, bzw. Markeninhaber und dienen lediglich der Beschreibung.

163	Mod. 345	Basel	Echt Alligatorenleder in glanz, Fullcut
163	Mod. 344	Zürich	Echt Alligatorenleder in matt, Fullcut
164	Mod. 341	Lausanne	Echt Alligatorenleder in glanz, Fullcut
164	Mod. 340	Geneve	Echt Alligatorenleder in matt, Fullcut



– Technische Angabe –

RIOS1931-Band, insbesondere passend für Uhren der Marke »Jäger le Coultre«

Alle aufgeführten Firmen, Marken und Kennzeichen sind Eigentum der jeweiligen Hersteller, bzw. Markeninhaber und dienen lediglich der Beschreibung.

165	Mod. 333	Avandgarde	Echt Alligatorenleder in matt, Fullcut
165	Mod. 332	Legend	Echt Alligatorenleder in matt, Fullcut
166	Mod. 330	Maxime	Echt Straußenleder



– Technische Angabe –

RIOS1931-Band, insbesondere passend für Uhren der Marke »TAG Heuer«

Alle aufgeführten Firmen, Marken und Kennzeichen sind Eigentum der jeweiligen Hersteller, bzw. Markeninhaber und dienen lediglich der Beschreibung.

166	Mod. 322	Projeter	Echt Alligatorenleder in matt, Fullcut
167	Mod. 320	Vision	Echt Juchtenleder



– Technische Angabe –

RIOS1931-Band, insbesondere passend für Uhren der Marke »Breitling«

Alle aufgeführten Firmen, Marken und Kennzeichen sind Eigentum der jeweiligen Hersteller, bzw. Markeninhaber und dienen lediglich der Beschreibung.

167	Mod. 316	Jet	Echt Alligatorenleder in matt, Fullcut
168	Mod. 315	Aero	Echt Alligatorenleder in matt, Fullcut
168	Mod. 312	Tornado	Echt Juchtenleder
169	Mod. 311	Pilot	Echt Juchtenleder
169	Mod. 310	Continental	Echt Haiifischleder



– Technical specification –

RIOS1931 watch strap, particularly suitable for watches of the brand »Patek Philippe«

All the listed companies, brands and symbols are the property of the respective manufacturer and/or brand owners and are for the descriptive purposes only.

163	Mod. 345	Basel	Genuine Alligator Leather, glossy finish, fullcut
163	Mod. 344	Zürich	Genuine Alligator Leather, matt finish, fullcut
164	Mod. 341	Lausanne	Genuine Alligator Leather, glossy finish, fullcut
164	Mod. 340	Geneve	Genuine Alligator Leather, matt finish, fullcut



– Technical specification –

RIOS1931 watch strap, particularly suitable for watches of the brand »Jäger le Coultre«

All the listed companies, brands and symbols are the property of the respective manufacturer and/or brand owners and are for the descriptive purposes only.

165	Mod. 333	Avandgarde	Genuine Alligator Leather, matt finish, fullcut
165	Mod. 332	Legend	Genuine Alligator Leather, matt finish, fullcut
166	Mod. 330	Maxime	Genuine Ostrich Leather



– Technical specification –

RIOS1931 watch strap, particularly suitable for watches of the brand »TAG Heuer«

All the listed companies, brands and symbols are the property of the respective manufacturer and/or brand owners and are for the descriptive purposes only.

166	Mod. 322	Projeter	Genuine Alligator Leather, matt finish, fullcut
167	Mod. 320	Vision	Genuine Russia Leather



– Technical specification –

RIOS1931 watch strap, particularly suitable for watches of the brand »Breitling«

All the listed companies, brands and symbols are the property of the respective manufacturer and/or brand owners and are for the descriptive purposes only.

167	Mod. 316	Jet	Genuine Alligator Leather, matt finish, fullcut
168	Mod. 315	Aero	Genuine Alligator Leather, matt finish, fullcut
168	Mod. 312	Tornado	Genuine Russia Leather
169	Mod. 311	Pilot	Genuine Russia Leather
169	Mod. 310	Continental	Genuine Shark Leather

Seite | Page 151
Mod. 474





Mod. 475 | **Messenger**

DE: *Echt zertifiziertes Bioleder | »Handnaht« | Naht: Cremeweiß | Bandstärke: ca. 2,5mm auf 2,5mm*

ENG: *Genuine Certified Organic Leather | »Saddler's Seam (Hand Seam)« | Seam: cream white | Thickness of strap: approx. 2.5mm to 2.5mm*



475 06
cognac
cognac

475 07
mokka
mocha

475 13
schwarz
black

DE: Alle aufgeführten Firmen, Marken und Kennzeichen sind Eigentum der jeweiligen Hersteller, bzw. Markeninhaber und dienen lediglich der Beschreibung.

ENG: All the listed companies, brands and symbols are the property of the respective manufacturer and /or brand owners and are for the descriptive purposes only.

Länge Length (mm)		M	
		128 72	
Breite Width			
Anstoß / Lug	Schließe / Buckle		
23,5mm	20,3mm		☪

Form Querschnitt | Cross-section:



»BLOCK« | »BLOCK«

– Technische Angabe –
RIOS1931-Band, insbesondere passend für Uhren der Marke »Apple (Smartwatch)«

– Technical specification –
RIOS1931 watch strap, particularly suitable for watches of the brand »Apple (Smartwatches)«



Mod. 474 | **Online**

DE: *Echt zertifiziertes Bioleder | »Handnaht« | Naht: Ton in Ton | Bandstärke: ca. 2,5mm auf 2,5mm*

ENG: *Genuine Certified Organic Leather | »Saddler's Seam (Hand Seam)« | Seam: matching stitching | Thickness of strap: approx. 2.5mm to 2.5mm*



474 06
cognac
cognac

474 07
mokka
mocha

474 13
schwarz
black

DE: Alle aufgeführten Firmen, Marken und Kennzeichen sind Eigentum der jeweiligen Hersteller, bzw. Markeninhaber und dienen lediglich der Beschreibung.

ENG: All the listed companies, brands and symbols are the property of the respective manufacturer and /or brand owners and are for the descriptive purposes only.

Länge Length (mm)		M	
		128 72	
Breite Width			
Anstoß / Lug	Schließe / Buckle		
23,5mm	20,3mm		☪

Form Querschnitt | Cross-section:



»BLOCK« | »BLOCK«

– Technische Angabe –
RIOS1931-Band, insbesondere passend für Uhren der Marke »Apple (Smartwatch)«

– Technical specification –
RIOS1931 watch strap, particularly suitable for watches of the brand »Apple (Smartwatches)«





Mod. **470** | **Stream**

DE: Alligatorenarbnung auf echt Rindsleder geprägt, in matt |
 Naht: Ton in Ton | Bandstärke: ca. 2,5mm auf 2,5mm
 ENG: Embossed Alligator Grain on Genuine Cow Leather, matt finish |
 Seam: matching stitching | Thickness of strap: approx. 2.5mm to 2.5mm



470 **05** mahagoni mahogany
 470 **06** cognac cognac
 470 **07** mokka mocha
 470 **13** schwarz black

Länge Length (mm)		M	
		128 72	
Breite Width			
Anstoß / Lug	Schließe / Buckle		
23,5mm	20,3mm		☾

Form Querschnitt | Cross-section:



»BLOCK« | »BLOCK«

– Technische Angabe –
 RIOS1931-Band, insbesondere
 passend für Uhren der Marke
 »Apple (Smartwatch)«

– Technical specification –
 RIOS1931 watch strap, particularly
 suitable for watches of the brand
 »Apple (Smartwatches)«

DE: Alle aufgeführten Firmen, Marken und Kennzeichen sind Eigentum der jeweiligen Hersteller, bzw. Markeninhaber und dienen lediglich der Beschreibung.

ENG: All the listed companies, brands and symbols are the property of the respective manufacturer and/or brand owners and are for the descriptive purposes only.



Mod. **464** | **Connect**

DE: Echt Büffelleleder |
 Naht: Ton in Ton | Bandstärke: ca. 2,5mm auf 2,5mm
 ENG: Genuine Buffalo Leather |
 Seam: matching stitching | Thickness of strap: approx. 2.5mm to 2.5mm



464 **06** cognac cognac
 464 **07** mokka mocha
 464 **12** ozeanblau ocean blue
 464 **13** schwarz black

Länge Length (mm)		M	
		128 72	
Breite Width			
Anstoß / Lug	Schließe / Buckle		
23,5mm	20,3mm		☾

Form Querschnitt | Cross-section:



»BLOCK« | »BLOCK«

– Technische Angabe –
 RIOS1931-Band, insbesondere
 passend für Uhren der Marke
 »Apple (Smartwatch)«

– Technical specification –
 RIOS1931 watch strap, particularly
 suitable for watches of the brand
 »Apple (Smartwatches)«

DE: Alle aufgeführten Firmen, Marken und Kennzeichen sind Eigentum der jeweiligen Hersteller, bzw. Markeninhaber und dienen lediglich der Beschreibung.

ENG: All the listed companies, brands and symbols are the property of the respective manufacturer and/or brand owners and are for the descriptive purposes only.



– Jedes Band ist ein Unikat –
Die Patina des Vintageleders kann stark unterschiedlich ausfallen.

– Every watch strap is unique –
The patina of the vintage leather can strongly vary.

Länge Length (mm)		M	
Breite Width		128 72	
Anstoß / Lug	Schließe / Buckle		
23,5mm	20,3mm		☾

Form Querschnitt | Cross-section:



»BLOCK« | »BLOCK«

– Technische Angabe –
RIOS1931-Band, insbesondere passend für Uhren der Marke »Apple (Smartwatch)«

– Technical specification –
RIOS1931 watch strap, particularly suitable for watches of the brand »Apple (Smartwatches)«

Mod. 460 | Life

DE: *Echt Vintageleder* |

Naht: *Ohne* | Bandstärke: *ca. 2,5 mm auf 2,5 mm*

ENG: *Genuine Vintage Leather* |

Seam: *no stitching* | Thickness of strap: *approx. 2.5 mm to 2.5 mm*



460 03
steingrau
stone grey

460 04
honig
honey

460 05
mahagoni
mahogany

460 06
cognac
cognac

460 07
mokka
mocha

460 13
schwarz
black

DE: Alle aufgeführten Firmen, Marken und Kennzeichen sind Eigentum der jeweiligen Hersteller, bzw. Markeninhaber und dienen lediglich der Beschreibung.

ENG: All the listed companies, brands and symbols are the property of the respective manufacturer and/or brand owners and are for the descriptive purposes only.



Seite | Page 152

Mod. 470



Mod. 396 | Master

DE: *Echt Alligatorenleder in matt, Fullcut | Für Faltschließe | »Art Manuel« | »Handnaht« | Naht Ton in Ton | Bandstärke: ca. 5,5mm auf 2,0mm*

ENG: *Genuine Alligator Leather, matt finish, fullcut | For folding buckle | »Art Manuel« | »Saddler's Seam (Hand Seam)« | Seam: matching stitching | Thickness of strap: approx. 5.5mm to 2.0mm*



396 **07**
mokka
mocha

396 **13**
schwarz
black

396 **14**
orange
orange

Länge Length (mm)		M	
Breite Width		104	100
Anstoß / Lug	Schließe / Buckle		
19 mm	16 mm	●	
20 mm	18 mm	●	
22 mm	18 mm	▲	

Form Querschnitt | Cross-section:



»RUND« | »ROUND«

– Technische Angabe –
RIOS1931-Band, insbesondere
passend für Uhren der Marke
»Omega«

– Technical specification –
RIOS1931 watch strap, particularly
suitable for watches of the brand
»Omega«

DE: Alle aufgeführten Firmen, Marken und Kennzeichen sind Eigentum der jeweiligen Hersteller, bzw. Markeninhaber und dienen lediglich der Beschreibung.

ENG: All the listed companies, brands and symbols are the property of the respective manufacturer and/or brand owners and are for the descriptive purposes only.



Mod. 390 | Engineer

DE: *Echt Juchtenleder | Für Faltschließe | »Art Manuel« | Naht: Cremeweiß oder Orange | Bandstärke: ca. 5,5 mm auf 2,0 mm*

ENG: *Genuine Russia Leather | For folding buckle | »Art Manuel« | Seam: cream white or orange | Thickness of strap: approx. 5.5 mm to 2.0 mm*



390 **13**
schwarz
black

390 **24**
schwarz | orange
black | orange

Länge Length (mm)		M	
Breite Width		104	100
Anstoß / Lug	Schließe / Buckle		
19 mm	16 mm	●	
20 mm	18 mm	●	
22 mm	18 mm	▲	

Form Querschnitt | Cross-section:



»RUND« | »ROUND«

– Technische Angabe –
RIOS1931-Band, insbesondere
passend für Uhren der Marke
»Omega«

– Technical specification –
RIOS1931 watch strap, particularly
suitable for watches of the brand
»Omega«

DE: Alle aufgeführten Firmen, Marken und Kennzeichen sind Eigentum der jeweiligen Hersteller, bzw. Markeninhaber und dienen lediglich der Beschreibung.

ENG: All the listed companies, brands and symbols are the property of the respective manufacturer and/or brand owners and are for the descriptive purposes only.



Mod. 389 Thunderbird

DE: Echt Alligatorenleder in matt, Fullcut | »Handnaht« | Naht: Cremeweiß | Bandstärke: ca. 4,5mm auf 3,0mm

ENG: Genuine Alligator Leather, matt finish, fullcut | »Saddler's Seam (Hand Seam)« | Seam: cream white | Thickness of strap: approx. 4.5mm to 3.0mm



389 05
mahagani
mahogany

389 06
cognac
cognac

389 07
mokka
mocha

389 12
ozeanblau
ocean blue

389 13
schwarz
black



389
Rückseiten
Reverse sides

Länge Length (mm)		M	
		114	74
Breite Width			
Anstoß / Lug	Schließe / Buckle		
18 mm	16 mm	●	
19 mm	16 mm	●	
20 mm	18 mm	●	
21 mm	18 mm	▲	
22 mm	18 mm	▲	

Form Querschnitt | Cross-section:



»ECKIG« | »SQUARE«

– Technische Angabe –
RIOS1931-Band, insbesondere
passend für Uhren der Marke
»IWC«

– Technical specification –
RIOS1931 watch strap, particularly
suitable for watches of the brand
»IWC«

DE: Alle aufgeführten Firmen, Marken und Kennzeichen sind Eigentum der jeweiligen Hersteller, bzw. Markeninhaber und dienen lediglich der Beschreibung.

ENG: All the listed companies, brands and symbols are the property of the respective manufacturer and/or brand owners and are for the descriptive purposes only.



Mod. 388 Spitfire

DE: Echt Alligatorenleder in matt, Fullcut | »Handnaht« | Naht: Ton in Ton | Bandstärke: ca. 4,5mm auf 3,0mm

ENG: Genuine Alligator Leather, matt finish, fullcut | »Saddler's Seam (Hand Seam)« | Seam: matching stitching | Thickness of strap: approx. 4.5mm to 3.0mm



388 05
mahagani
mahogany

388 06
cognac
cognac

388 07
mokka
mocha

388 12
ozeanblau
ocean blue

388 13
schwarz
black



388
Rückseiten
Reverse sides

Länge Length (mm)		M	
		114	74
Breite Width			
Anstoß / Lug	Schließe / Buckle		
18 mm	16 mm	●	
19 mm	16 mm	●	
20 mm	18 mm	●	
21 mm	18 mm	▲	
22 mm	18 mm	▲	

Form Querschnitt | Cross-section:



»ECKIG« | »SQUARE«

– Technische Angabe –
RIOS1931-Band, insbesondere
passend für Uhren der Marke
»IWC«

– Technical specification –
RIOS1931 watch strap, particularly
suitable for watches of the brand
»IWC«

DE: Alle aufgeführten Firmen, Marken und Kennzeichen sind Eigentum der jeweiligen Hersteller, bzw. Markeninhaber und dienen lediglich der Beschreibung.

ENG: All the listed companies, brands and symbols are the property of the respective manufacturer and/or brand owners and are for the descriptive purposes only.



Mod. **386** Hurricane

DE: *Echt Alligatorenleder in matt, Fullcut | »Handnaht«* |
 Naht: *Cremeweiß* | *Bandstärke: ca. 3,5 mm auf 3,5 mm*

ENG: *Genuine Alligator Leather, matt finish, fullcut | »Saddler's Seam (Hand Seam)«* |
 Seam: *cream white* | *Thickness of strap: approx. 3.5 mm to 3.5 mm*



386 **05**
mahagoni
mahogany

386 **06**
cognac
cognac

386 **07**
mokka
mocha

386 **13**
schwarz
black



386
Rückseiten
Reverse sides

Länge Length (mm)		M	
		118	82
Breite Width			
Anstoß / Lug	Schleße / Buckle		
20 mm	18 mm	●	
21 mm	18 mm	▲	
22 mm	18 mm	▲	

Form Querschnitt | Cross-section:



»BLOCK« | »BLOCK«

– Technische Angabe –
 RIOS1931-Band, insbesondere
 passend für Uhren der Marke
 »IWC«

– Technical specification –
 RIOS1931 watch strap, particularly
 suitable for watches of the brand
 »IWC«

DE: Alle aufgeführten Firmen, Marken und Kennzeichen sind Eigentum der jeweiligen Hersteller, bzw. Markeninhaber und dienen lediglich der Beschreibung.

ENG: All the listed companies, brands and symbols are the property of the respective manufacturer and/or brand owners and are for the descriptive purposes only.



Mod. **385** Typhoon

DE: *Echt Büffelleleder* |
 Naht: *Cremeweiß* | *Bandstärke: ca. 3,5 mm auf 3,5 mm*

ENG: *Genuine Buffalo Leather* |
 Seam: *cream white* | *Thickness of strap: approx. 3.5 mm to 3.5 mm*



385 **06**
cognac
cognac

385 **07**
mokka
mocha

385 **13**
schwarz
black



385
Rückseiten
Reverse sides

Länge Length (mm)		M	
		118	82
Breite Width			
Anstoß / Lug	Schleße / Buckle		
20 mm	18 mm	●	
21 mm	18 mm	▲	
22 mm	18 mm	▲	

Form Querschnitt | Cross-section:



»BLOCK« | »BLOCK«

– Technische Angabe –
 RIOS1931-Band, insbesondere
 passend für Uhren der Marke
 »IWC«

– Technical specification –
 RIOS1931 watch strap, particularly
 suitable for watches of the brand
 »IWC«

DE: Alle aufgeführten Firmen, Marken und Kennzeichen sind Eigentum der jeweiligen Hersteller, bzw. Markeninhaber und dienen lediglich der Beschreibung.

ENG: All the listed companies, brands and symbols are the property of the respective manufacturer and/or brand owners and are for the descriptive purposes only.



Mod. 384 | **Blizzard**

DE: *Echt Kalbsleder* |
 Naht: *Cremeweiß* | *Bandstärke: ca. 3,5 mm auf 3,5 mm*
 ENG: *Genuine Calfskin* |
 Seam: *cream white* | *Thickness of strap: approx. 3.5 mm to 3.5 mm*



384 06
cognac
cognac

384 07
mokka
mocha

384 13
schwarz
black



384
Rückseiten
Reverse sides

Länge Length (mm)		M	
		118	82
Breite Width			
Anstoß / Lug	Schließe / Buckle		
20 mm	18 mm	●	
21 mm	18 mm	▲	
22 mm	18 mm	▲	

Form Querschnitt | Cross-section:



»BLOCK« | »BLOCK«

– **Technische Angabe** –
 RIOS1931-Band, insbesondere
 passend für Uhren der Marke
 »IWC«

– **Technical specification** –
 RIOS1931 watch strap, particularly
 suitable for watches of the brand
 »IWC«

DE: Alle aufgeführten Firmen, Marken und Kennzeichen sind Eigentum der jeweiligen Hersteller, bzw. Markeninhaber und dienen lediglich der Beschreibung.

ENG: All the listed companies, brands and symbols are the property of the respective manufacturer and/or brand owners and are for the descriptive purposes only.



Mod. 383 | **Scirocco**

DE: *Echt Kalbsleder* |
 Naht: *Ton in Ton* | *Bandstärke: ca. 3,5 mm auf 3,5 mm*
 ENG: *Genuine Calfskin* |
 Seam: *matching stitching* | *Thickness of strap: approx. 3.5 mm to 3.5 mm*



383 06
cognac
cognac

383 07
mokka
mocha

383 13
schwarz
black



383
Rückseiten
Reverse sides

Länge Length (mm)		M	
		118	82
Breite Width			
Anstoß / Lug	Schließe / Buckle		
20 mm	18 mm	●	
21 mm	18 mm	▲	
22 mm	18 mm	▲	

Form Querschnitt | Cross-section:



»BLOCK« | »BLOCK«

– **Technische Angabe** –
 RIOS1931-Band, insbesondere
 passend für Uhren der Marke
 »IWC«

– **Technical specification** –
 RIOS1931 watch strap, particularly
 suitable for watches of the brand
 »IWC«

DE: Alle aufgeführten Firmen, Marken und Kennzeichen sind Eigentum der jeweiligen Hersteller, bzw. Markeninhaber und dienen lediglich der Beschreibung.

ENG: All the listed companies, brands and symbols are the property of the respective manufacturer and/or brand owners and are for the descriptive purposes only.



Mod. 382 | Albatros

DE: Hightechmaterial Nytech | »Wasserresistent« |
 Naht: Ton in Ton | Bandstärke: ca. 3,5mm auf 3,5mm
 ENG: Hightech Material Nytech | »Water resistant« |
 Seam: matching stitching | Thickness of strap: approx. 3.5 mm to 3.5 mm



382 13
schwarz
black



382
Rückseiten
Reverse sides

Länge Length (mm)		M	
		114	82
Breite Width			
Anstoß / Lug	Schleife / Buckle		
18 mm	16 mm	●	
20 mm	18 mm	●	
22 mm	18 mm	▲	

Form Querschnitt | Cross-section:



»BLOCK« | »BLOCK«

– Technische Angabe –
 RIOS1931-Band, insbesondere
 passend für Uhren der Marke
 »IWC«

– Technical specification –
 RIOS1931 watch strap, particularly
 suitable for watches of the brand
 »IWC«

DE: Alle aufgeführten Firmen, Marken und Kennzeichen sind Eigentum der jeweiligen Hersteller, bzw. Markeninhaber und dienen lediglich der Beschreibung.

ENG: All the listed companies, brands and symbols are the property of the respective manufacturer and/or brand owners and are for the descriptive purposes only.



Mod. 380 | Copter

DE: Echt Juchtenleder |
 Naht: Cremeweiß | Bandstärke: ca. 4,0mm auf 4,0mm
 ENG: Genuine Russia Leather |
 Seam: cream white | Thickness of strap: approx. 4,0mm to 4,0mm



380 02
sand
sand



380 03
steingrau
cognac



380 04
honig
honey



380 06
cognac
cognac



380 07
mokka
mocha



380 13
schwarz
black

Länge Length (mm)		M	
		115	75
Breite Width			
Anstoß / Lug	Schleife / Buckle		
24 mm	24 mm	◐	

Form Querschnitt | Cross-section:



»BLOCK« | »BLOCK«

– Technische Angabe –
 RIOS1931-Band, insbesondere
 passend für Uhren der Marke
 »Bell & Ross«

– Technical specification –
 RIOS1931 watch strap, particularly
 suitable for watches of the brand
 »Bell & Ross«

DE: Alle aufgeführten Firmen, Marken und Kennzeichen sind Eigentum der jeweiligen Hersteller, bzw. Markeninhaber und dienen lediglich der Beschreibung.

ENG: All the listed companies, brands and symbols are the property of the respective manufacturer and/or brand owners and are for the descriptive purposes only.



Länge Length (mm)		M	
		77	67
Breite Width			
Anstoß / Lug	Schließe / Buckle		
20 mm	16 mm		●

Form Querschnitt | Cross-section:



»ECKIG« | »SQUARE«

– Technische Angabe –
RIOS1931-Band, insbesondere
passend für Uhren der Marke
»Rolex (Daytona)«

– Technical specification –
RIOS1931 watch strap, particularly
suitable for watches of the brand
»Rolex (Daytona)«

Mod. 371 | **Prince**

DE: Echt Alligatorenleder in glanz, Fullcut | Für Faltschließe | »Art Manuel« | »Handnaht« |
Naht: Ton in Ton | Bandstärke: ca. 3,5 mm auf 3,5 mm

ENG: Genuine Alligator Leather, glossy finish, fullcut | For folding buckle | »Art Manuel« | »Saddler's Seam (Hand Seam)« |
Seam: matching stitching | Thickness of strap: approx. 3.5 mm to 3.5 mm



371 05
mahagani
mahogany

371 07
mokka
mocha

371 12
ozeanblau
ocean blue

371 13
schwarz
black

DE: Alle aufgeführten Firmen, Marken und Kennzeichen sind Eigentum der jeweiligen Hersteller, bzw. Markeninhaber und dienen lediglich der Beschreibung.

ENG: All the listed companies, brands and symbols are the property of the respective manufacturer and/or brand owners and are for the descriptive purposes only.



Länge Length (mm)		M	
		77	67
Breite Width			
Anstoß / Lug	Schließe / Buckle		
20 mm	16 mm		●

Form Querschnitt | Cross-section:



»ECKIG« | »SQUARE«

– Technische Angabe –
RIOS1931-Band, insbesondere
passend für Uhren der Marke
»Rolex (Daytona)«

– Technical specification –
RIOS1931 watch strap, particularly
suitable for watches of the brand
»Rolex (Daytona)«

Mod. 370 | **King**

DE: Echt Alligatorenleder in matt, Fullcut | Für Faltschließe | »Art Manuel« | »Handnaht« |
Naht: Ton in Ton | Bandstärke: ca. 3,5 mm auf 3,5 mm

ENG: Genuine Alligator Leather, matt finish, fullcut | For folding buckle | »Art Manuel« | »Saddler's Seam (Hand Seam)« |
Seam: matching stitching | Thickness of strap: approx. 3.5 mm to 3.5 mm



370 05
mahagani
mahogany

370 06
cognac
cognac

370 07
mokka
mocha

370 12
ozeanblau
ocean blue

370 13
schwarz
black

DE: Alle aufgeführten Firmen, Marken und Kennzeichen sind Eigentum der jeweiligen Hersteller, bzw. Markeninhaber und dienen lediglich der Beschreibung.

ENG: All the listed companies, brands and symbols are the property of the respective manufacturer and/or brand owners and are for the descriptive purposes only.



Mod. 364 Pisa

DE: *Echt Alligatorenleder in matt, Fullcut | Für Faltschließe | »Art Manuel« | »Handnaht« | Naht: Cremeweiß | Bandstärke: ca. 4,5mm auf 2,0mm*

ENG: *Genuine Alligator Leather, matt finish, fullcut | For folding buckle | »Art Manuel« | »Saddler's Seam (Hand Seam)« | Seam: cream white | Thickness of strap: approx. 4.5mm to 2.0mm*



364 05
mahagoni
mahogany

364 06
cognac
cognac

364 07
mokka
mocha

364 13
schwarz
black

Länge Length (mm)		M	
		115	75
Breite Width			
Anstoß / Lug	Schließe / Buckle		
24 mm	22 mm		☾

Form Querschnitt | Cross-section:



»ECKIG« | »SQUARE«

– Technische Angabe –
RIOS1931-Band, insbesondere
passend für Uhren der Marke
»Officine Panerai«

– Technical specification –
RIOS1931 watch strap, particularly
suitable for watches of the brand
»Officine Panerai«

DE: Alle aufgeführten Firmen, Marken und Kennzeichen sind Eigentum der jeweiligen Hersteller, bzw. Markeninhaber und dienen lediglich der Beschreibung.

ENG: All the listed companies, brands and symbols are the property of the respective manufacturer and/or brand owners and are for the descriptive purposes only.



Mod. 363 Modena

DE: *Echt Alligatorenleder in matt, Fullcut | Für Dornschließe | »Art Manuel« | »Handnaht« | Naht: Cremeweiß | Bandstärke: ca. 4,5mm auf 4,5mm*

ENG: *Genuine Alligator Leather, matt finish, fullcut | For pin buckle | »Art Manuel« | »Saddler's Seam (Hand Seam)« | Seam: cream white | Thickness of strap: approx. 4.5mm to 4.5mm*



363 05
mahagoni
mahogany

363 06
cognac
cognac

363 07
mokka
mocha

363 12
ozeanblau
ocean blue

363 13
schwarz
black

– Lieferung OHNE Schließe –
Bitte wählen Sie auf den
Seiten 182/183



– Supplied WITHOUT clasp –
Please select a clasp on
pages 182/183

Länge Length (mm)		M	
		115	75
Breite Width			
Anstoß / Lug	Schließe / Buckle		
24 mm	22 mm		☾

Form Querschnitt | Cross-section:



»ECKIG« | »SQUARE«

– Technische Angabe –
RIOS1931-Band, insbesondere
passend für Uhren der Marke
»Officine Panerai«

– Technical specification –
RIOS1931 watch strap, particularly
suitable for watches of the brand
»Officine Panerai«

DE: Alle aufgeführten Firmen, Marken und Kennzeichen sind Eigentum der jeweiligen Hersteller, bzw. Markeninhaber und dienen lediglich der Beschreibung.

ENG: All the listed companies, brands and symbols are the property of the respective manufacturer and/or brand owners and are for the descriptive purposes only.



– Lieferung OHNE Schließe –
Bitte wählen Sie auf den
Seiten 182/183



– Supplied WITHOUT clasp –
Please select a clasp on
pages 182/183

Länge Length (mm)		M	
		115	75
Breite Width			
Anstoß / Lug	Schließe / Buckle		
22 mm	22 mm	▲	
24 mm	22 mm	◐	
24 mm	24 mm	◑	
26 mm	22 mm	◒	
26 mm	26 mm	◓	

Form Querschnitt | Cross-section:



»ECKIG« | »SQUARE«

– Technische Angabe –
RIOS1931-Band, insbesondere
passend für Uhren der Marke
»Officine Panerei«

– Technical specification –
RIOS1931 watch strap, particularly
suitable for watches of the brand
»Officine Panerei«

Mod. 361 | **Milano**

DE: Echt Rindsleder (Hydrophobiert) | Für Dornschnieße | »Wasserresistent« |
Naht: Ton in Ton | Bandstärke: ca. 4,5 mm auf 4,5 mm

ENG: Genuine Cow Leather (Hydrophobicity) | For pin buckle | »Water resistant« |
Seam: matching stitching | Thickness of strap: approx. 4.5 mm to 4.5 mm



361 05
mahagoni
mahogany

361 07
mokka
mocha

361 13
schwarz
black



361
Rückseiten
Reverse sides

DE: Alle aufgeführten Firmen, Marken und Kennzeichen sind Eigentum der jeweiligen Hersteller, bzw. Markeninhaber und dienen lediglich der Beschreibung.

ENG: All the listed companies, brands and symbols are the property of the respective manufacturer and/or brand owners and are for the descriptive purposes only.



– Lieferung OHNE Schließe –
Bitte wählen Sie auf den
Seiten 182/183



– Supplied WITHOUT clasp –
Please select a clasp on
pages 182/183

Länge Length (mm)		M		XL
		115	75	124 92
Breite Width				
Anstoß / Lug	Schließe / Buckle			
22 mm	22 mm	▲	◆	
24 mm	22 mm	◐	★	
24 mm	24 mm	◑	★	
26 mm	22 mm	◒	+	
26 mm	26 mm	◓	+	

Form Querschnitt | Cross-section:



»ECKIG« | »SQUARE«

– Technische Angabe –
RIOS1931-Band, insbesondere
passend für Uhren der Marke
»Officine Panerei«

– Technical specification –
RIOS1931 watch strap, particularly
suitable for watches of the brand
»Officine Panerei«

Mod. 360 | **Firenze**

DE: Echt Juchtenleder | Für Dornschnieße |
Naht: Cremeweiß | Bandstärke: ca. 4,5 mm auf 4,5 mm

ENG: Genuine Russia Leather | For pin buckle |
Seam: cream white | Thickness of strap: approx. 4.5 mm to 4.5 mm



360 02
sand
sand

360 03
steingrau
stone grey

360 06
cognac
cognac

360 07
mokka
mocha

360 13
schwarz
black

DE: Alle aufgeführten Firmen, Marken und Kennzeichen sind Eigentum der jeweiligen Hersteller, bzw. Markeninhaber und dienen lediglich der Beschreibung.

ENG: All the listed companies, brands and symbols are the property of the respective manufacturer and/or brand owners and are for the descriptive purposes only.



Mod. 352 | Louvre

DE: *Echt Alligatorenleder in matt, Fullcut | Für Faltschließe | »Art Manuel« | »Handnaht« | Naht: Ton in Ton | Bandstärke: ca. 3,0mm auf 1,0mm*

ENG: *Genuine Alligator Leather, matt finish, fullcut | For folding buckle | »Art Manuel« | »Saddler's Seam (Hand Seam) | Seam: matching stitching | Thickness of strap: approx. 3.0mm to 1.0mm*



352 05
mahagony
mahogany

352 06
cognac
cognac

352 07
mokka
mocha

352 12
ozeanblau
ocean blue

352 13
schwarz
black

Länge Length (mm)		S	M
		100 85	114 82
Breite Width			
Anstoß / Lug	Schließe / Buckle		
16 mm	14 mm	●	
17 mm	16 mm	●	
18 mm	16 mm	●	●
20 mm	18 mm		●

Form Querschnitt | Cross-section:



»ECKIG« | »SQUARE«

– Technische Angabe –
RIOS1931-Band, insbesondere
passend für Uhren der Marke
»Cartier (Tank)«

– Technical specification –
RIOS1931 watch strap, particularly
suitable for watches of the brand
»Cartier (Tank)«

DE: Alle aufgeführten Firmen, Marken und Kennzeichen sind Eigentum der jeweiligen Hersteller, bzw. Markeninhaber und dienen lediglich der Beschreibung.

ENG: All the listed companies, brands and symbols are the property of the respective manufacturer and/or brand owners and are for the descriptive purposes only.



Mod. 350 | Versailles

DE: *Echt Alligatorenleder in matt, Fullcut | Für Faltschließe | »Art Manuel« | »Handnaht« | Naht: Ton in Ton | Bandstärke: ca. 6,0mm auf 1,0mm*

ENG: *Genuine Alligator Leather, matt finish, fullcut | For folding buckle | »Art Manuel« | »Saddler's Seam (Hand Seam) | Seam: matching stitching | Thickness of strap: approx. 6.0mm to 1.0mm*



350 05
mahagony
mahogany

350 06
cognac
cognac

350 07
mokka
mocha

350 12
ozeanblau
ocean blue

350 13
schwarz
black

Länge Length (mm)		M
		114 82
Breite Width		
Anstoß / Lug	Schließe / Buckle	
18 mm	16 mm	●
20 mm	18 mm	●

Form Querschnitt | Cross-section:



»RUND« | »ROUND«

– Technische Angabe –
RIOS1931-Band, insbesondere
passend für Uhren der Marke
»Cartier (Pasha)«

– Technical specification –
RIOS1931 watch strap, particularly
suitable for watches of the brand
»Cartier (Pasha)«

DE: Alle aufgeführten Firmen, Marken und Kennzeichen sind Eigentum der jeweiligen Hersteller, bzw. Markeninhaber und dienen lediglich der Beschreibung.

ENG: All the listed companies, brands and symbols are the property of the respective manufacturer and/or brand owners and are for the descriptive purposes only.



Mod. 345 | Basel

DE: *Echt Alligatorenleder in glanz, Fullcut | »Art Manuel« | Naht: Ohne | Bandstärke: ca. 2,0mm auf 2,0mm*

ENG: *Genuine Alligator Leather, glossy finish, fullcut | »Art Manuel« | Seam: no stitching | Thickness of strap: approx. 2.0mm to 2.0mm*



345 05 mahagoni mahogany
345 07 mokka mocha
345 12 ozeanblau ocean blue
345 13 schwarz black

Länge Length (mm)		M	
		114	82
Breite Width			
Anstoß / Lug	Schließe / Buckle		
17 mm	16 mm	●	
18 mm	14 mm	●	
19 mm	14 mm	●	
21 mm	16 mm	▲	

Form Querschnitt | Cross-section:

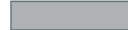

»BLOCK« | »BLOCK«

– Technische Angabe –
RIOS1931-Band, insbesondere
passend für Uhren der Marke
»Patek Philippe«

– Technical specification –
RIOS1931 watch strap, particularly
suitable for watches of the brand
»Patek Philippe«

DE: Alle aufgeführten Firmen, Marken und Kennzeichen sind Eigentum der jeweiligen Hersteller, bzw. Markeninhaber und dienen lediglich der Beschreibung.

ENG: All the listed companies, brands and symbols are the property of the respective manufacturer and/or brand owners and are for the descriptive purposes only.



Mod. 344 | Zürich

DE: *Echt Alligatorenleder in matt, Fullcut | »Art Manuel« | Naht: Ohne | Bandstärke: ca. 2,0mm auf 2,0mm*

ENG: *Genuine Alligator Leather, matt finish, fullcut | »Art Manuel« | Seam: no stitching | Thickness of strap: approx. 2.0mm to 2.0mm*



344 05 mahagoni mahogany
344 06 cognac cognac
344 07 mokka mocha
344 12 ozeanblau ocean blue
344 13 schwarz black

Länge Length (mm)		M	
		114	82
Breite Width			
Anstoß / Lug	Schließe / Buckle		
17 mm	16 mm	●	
18 mm	14 mm	●	
19 mm	14 mm	●	
21 mm	16 mm	▲	

Form Querschnitt | Cross-section:



»BLOCK« | »BLOCK«

– Technische Angabe –
RIOS1931-Band, insbesondere
passend für Uhren der Marke
»Patek Philippe«

– Technical specification –
RIOS1931 watch strap, particularly
suitable for watches of the brand
»Patek Philippe«

DE: Alle aufgeführten Firmen, Marken und Kennzeichen sind Eigentum der jeweiligen Hersteller, bzw. Markeninhaber und dienen lediglich der Beschreibung.

ENG: All the listed companies, brands and symbols are the property of the respective manufacturer and/or brand owners and are for the descriptive purposes only.



Mod. 341 | Lausanne

DE: *Echt Alligatorenleder in glanz, Fullcut* | »Art Manuel« | »Handnaht« |
Naht: *Ton in Ton* | Bandstärke: *ca. 3,0mm auf 2,0mm*

ENG: *Genuine Alligator Leather, glossy finish, fullcut* | »Art Manuel« | »Saddler's Seam (Hand Seam) |
Seam: *matching stitching* | Thickness of strap: *approx. 3.0mm to 2.0mm*



341 05
mahagoni
mahogany

341 07
mokka
mocha

341 12
ozeanblau
ocean blue

341 13
schwarz
black

Länge Length (mm)		M	
		114	82
Breite Width			
Anstoß / Lug	Schleife / Buckle		
18 mm	14 mm	●	
19 mm	14 mm	●	
20 mm	16 mm	●	
21 mm	16 mm	▲	

Form Querschnitt | Cross-section:



»ECKIG« | »SQUARE«

– Technische Angabe –
RIOS1931-Band, insbesondere
passend für Uhren der Marke
»Patek Philippe«

– Technical specification –
RIOS1931 watch strap, particularly
suitable for watches of the brand
»Patek Philippe«

DE: Alle aufgeführten Firmen, Marken und Kennzeichen sind Eigentum der jeweiligen Hersteller, bzw. Markeninhaber und dienen lediglich der Beschreibung.

ENG: All the listed companies, brands and symbols are the property of the respective manufacturer and/or brand owners and are for the descriptive purposes only.



Mod. 340 | Geneve

DE: *Echt Alligatorenleder in matt, Fullcut* | »Art Manuel« | »Handnaht« |
Naht: *Ton in Ton* | Bandstärke: *ca. 3,0mm auf 2,0mm*

ENG: *Genuine Alligator Leather, matt finish, fullcut* | »Art Manuel« | »Saddler's Seam (Hand Seam) |
Seam: *matching stitching* | Thickness of strap: *approx. 3.0mm to 2.0mm*



340 05
mahagoni
mahogany

340 06
cognac
cognac

340 07
mokka
mocha

340 12
ozeanblau
ocean blue

340 13
schwarz
black

Länge Length (mm)		M	
		114	82
Breite Width			
Anstoß / Lug	Schleife / Buckle		
18 mm	14 mm	●	
19 mm	14 mm	●	
20 mm	16 mm	●	
21 mm	16 mm	▲	

Form Querschnitt | Cross-section:



»ECKIG« | »SQUARE«

– Technische Angabe –
RIOS1931-Band, insbesondere
passend für Uhren der Marke
»Patek Philippe«

– Technical specification –
RIOS1931 watch strap, particularly
suitable for watches of the brand
»Patek Philippe«

DE: Alle aufgeführten Firmen, Marken und Kennzeichen sind Eigentum der jeweiligen Hersteller, bzw. Markeninhaber und dienen lediglich der Beschreibung.

ENG: All the listed companies, brands and symbols are the property of the respective manufacturer and/or brand owners and are for the descriptive purposes only.



Mod. 333 | **Avandgarde**

DE: *Echt Alligatorenleder in matt, Fullcut | Runder Anstoß | »Art Manuel« | »Handnaht« | Naht: Cremeweiß | Bandstärke: ca. 4,0mm auf 2,0mm*

ENG: *Genuine Alligator Leather, matt finish, fullcut | Rounded end | »Art Manuel« | »Saddler's Seam (Hand Seam) | Seam: cream white | Thickness of strap: approx. 4.0mm to 2.0mm*



333 05
mahagani
mahogany

333 06
cognac
cognac

333 07
mokka
mocha

333 13
schwarz
black

Länge Length (mm)		M	
		114	82
Breite Width			
Anstoß / Lug	Schließe / Buckle		
19 mm	16 mm	●	
20 mm	16 mm	●	

Form Querschnitt | Cross-section:



»RUND« | »ROUND«

- Technische Angabe – RIOS1931-Band, insbesondere passend für Uhren der Marke »Jäger le Coultre«
- Technical specification – RIOS1931 watch strap, particularly suitable for watches of the brand »Jäger le Coultre«

DE: Alle aufgeführten Firmen, Marken und Kennzeichen sind Eigentum der jeweiligen Hersteller, bzw. Markeninhaber und dienen lediglich der Beschreibung.

ENG: All the listed companies, brands and symbols are the property of the respective manufacturer and/or brand owners and are for the descriptive purposes only.



Mod. 332 | **Legend**

DE: *Echt Alligatorenleder in matt, Fullcut | Runder Anstoß | »Art Manuel« | »Handnaht« | Naht: Ton in Ton | Bandstärke: ca. 4,0mm auf 2,0mm*

ENG: *Genuine Alligator Leather, matt finish, fullcut | Rounded end | »Art Manuel« | »Saddler's Seam (Hand Seam) | Seam: matching stitching | Thickness of strap: approx. 4.0mm to 2.0mm*



332 05
mahagani
mahogany

332 06
cognac
cognac

332 07
mokka
mocha

332 13
schwarz
black

Länge Length (mm)		M	
		114	82
Breite Width			
Anstoß / Lug	Schließe / Buckle		
19 mm	16 mm	●	
20 mm	16 mm	●	

Form Querschnitt | Cross-section:



»RUND« | »ROUND«

- Technische Angabe – RIOS1931-Band, insbesondere passend für Uhren der Marke »Jäger le Coultre«
- Technical specification – RIOS1931 watch strap, particularly suitable for watches of the brand »Jäger le Coultre«

DE: Alle aufgeführten Firmen, Marken und Kennzeichen sind Eigentum der jeweiligen Hersteller, bzw. Markeninhaber und dienen lediglich der Beschreibung.

ENG: All the listed companies, brands and symbols are the property of the respective manufacturer and/or brand owners and are for the descriptive purposes only.



Mod. **330** | **Maxime**

DE: *Echt Straußenleder* | »Art Manuel« |
 Naht: *Cremeweiß* | *Bandstärke: ca. 3,5 mm auf 3,0 mm*
 ENG: *Genuine Ostrich Leather* | »Art Manuel« |
 Seam: *cream white* | *Thickness of strap: approx. 3.5 mm to 3.0 mm*



330 **06**
cognac
cognac

330 **13**
schwarz
black

Länge Length (mm)		M	
Breite Width		114	82
Anstoß / Lug	Schleße / Buckle		
18 mm	16 mm	●	
19 mm	16 mm	●	
20 mm	16 mm	●	

Form Querschnitt | Cross-section:



»ECKIG« | »SQUARE«

– **Technische Angabe** –
 RIOS1931-Band, insbesondere
 passend für Uhren der Marke
 »Jäger le Coultre«

– **Technical specification** –
 RIOS1931 watch strap, particularly
 suitable for watches of the brand
 »Jäger le Coultre«

DE: Alle aufgeführten Firmen, Marken und Kennzeichen sind Eigentum der jeweiligen Hersteller, bzw. Markeninhaber und dienen lediglich der Beschreibung.

ENG: All the listed companies, brands and symbols are the property of the respective manufacturer and/or brand owners and are for the descriptive purposes only.



Mod. **322** | **Projeter**

DE: *Echt Alligatorenleder in matt, Fullcut* | *Für Faltschleße* | »Art Manuel« |
 »Handnaht« | *Naht: Ton in Ton* | *Bandstärke: ca. 3,5 mm auf 1,8 mm*
 ENG: *Genuine Alligator Leather, matt finish, fullcut* | *For folding buckle* | »Art Manuel« |
 »Saddler's Seam (Hand Seam)« | *Seam: matching stitching* | *Thickness of strap: approx. 3.5 mm to 1.8 mm*



322 **07**
mokka
mocha

322 **12**
ozeanblau
ocean blue

322 **13**
schwarz
black

Länge Length (mm)		M	
Breite Width		104	84
Anstoß / Lug	Schleße / Buckle		
20 mm	16 mm	●	
22 mm	18 mm	▲	

Form Querschnitt | Cross-section:



»RUND« | »ROUND«

– **Technische Angabe** –
 RIOS1931-Band, insbesondere
 passend für Uhren der Marke
 »TAG Heuer«

– **Technical specification** –
 RIOS1931 watch strap, particularly
 suitable for watches of the brand
 »TAG Heuer«

DE: Alle aufgeführten Firmen, Marken und Kennzeichen sind Eigentum der jeweiligen Hersteller, bzw. Markeninhaber und dienen lediglich der Beschreibung.

ENG: All the listed companies, brands and symbols are the property of the respective manufacturer and/or brand owners and are for the descriptive purposes only.



Mod. 320 Vision

DE: *Echt Juchtenleder | Für Faltschließe | »Art Manuel« | Naht: Ton in Ton | Bandstärke: ca. 4,5mm auf 1,8mm*
 ENG: *Genuine Russia Leather | For folding buckle | »Art Manuel« | Seam: matching stitching | Thickness of strap: approx. 4.5mm to 1.8mm*



320 07 mokka
mocha
320 13 schwarz
black

Länge Length (mm)		M	
		104	84
Breite Width			
Anstoß / Lug	Schließe / Buckle		
20mm	16mm	●	
22mm	18mm	▲	

Form Querschnitt | Cross-section:



»RUND« | »ROUND«

– Technische Angabe –
 RIOS1931-Band, insbesondere
 passend für Uhren der Marke
 »TAG Heuer«

– Technical specification –
 RIOS1931 watch strap, particularly
 suitable for watches of the brand
 »TAG Heuer«

DE: Alle aufgeführten Firmen, Marken und Kennzeichen sind Eigentum der jeweiligen Hersteller, bzw. Markeninhaber und dienen lediglich der Beschreibung.

ENG: All the listed companies, brands and symbols are the property of the respective manufacturer and/or brand owners and are for the descriptive purposes only.



Mod. 316 Jet

DE: *Echt Alligatorenleder in matt, Fullcut | Für Dornschnieße | »Handnaht« | Naht: Cremeweiß | Bandstärke: ca. 7,0mm auf 3,0mm*
 ENG: *Genuine Alligator Leather, matt finish, fullcut | For pin buckle | »Saddler's Seam (Hand Seam)« | Seam: cream white | Thickness of strap: approx. 7.0mm to 3.0mm*



316 05 mahagani
mahogany
316 06 cognac
cognac
316 07 mokka
mocha
316 13 schwarz
black

Länge Length (mm)		M	
		114	82
Breite Width			
Anstoß / Lug	Schließe / Buckle		
20mm	18mm	●	
22mm	18mm	▲	
22mm	20mm	▲	
24mm	20mm	◐	

Form Querschnitt | Cross-section:



»RUND« | »ROUND«

– Technische Angabe –
 RIOS1931-Band, insbesondere
 passend für Uhren der Marke
 »Breitling«

– Technical specification –
 RIOS1931 watch strap, particularly
 suitable for watches of the brand
 »Breitling«

DE: Alle aufgeführten Firmen, Marken und Kennzeichen sind Eigentum der jeweiligen Hersteller, bzw. Markeninhaber und dienen lediglich der Beschreibung.

ENG: All the listed companies, brands and symbols are the property of the respective manufacturer and/or brand owners and are for the descriptive purposes only.



Mod. 315 | Aero

DE: *Echt Alligatorenleder in matt, Fullcut | Für Faltschließe | »Art Manuel« | »Handnaht« | Naht: Cremeweiß | Bandstärke: ca. 7,0mm auf 2,5mm*

ENG: *Genuine Alligator Leather, matt finish, fullcut | For folding buckle | »Art Manuel« | »Saddler's Seam (Hand Seam)« | Seam: cream white | Thickness of strap: approx. 7.0mm to 2.5mm*



315 05
mahagoni
mahogany

315 06
cognac
cognac

315 07
mokka
mocha

315 13
schwarz
black

Länge Length (mm)		M	
Breite Width		110	90
Anstoß / Lug	Schließe / Buckle		
20 mm	18 mm	●	
22 mm	18 mm	▲	
22 mm	20 mm	▲	

Form Querschnitt | Cross-section:



»RUND« | »ROUND«

– Technische Angabe –
RIOS1931-Band, insbesondere
passend für Uhren der Marke
»Breitling«

– Technical specification –
RIOS1931 watch strap, particularly
suitable for watches of the brand
»Breitling«

DE: Alle aufgeführten Firmen, Marken und Kennzeichen sind Eigentum der jeweiligen Hersteller, bzw. Markeninhaber und dienen lediglich der Beschreibung.

ENG: All the listed companies, brands and symbols are the property of the respective manufacturer and/or brand owners and are for the descriptive purposes only.



Mod. 312 | Tornado

DE: *Echt Juchtenleder | Für Dornschnließe | Naht: Cremeweiß | Bandstärke: ca. 7,0mm auf 3,0mm*

ENG: *Genuine Russia Leather | For pin buckles | Seam: cream white | Thickness of strap: approx. 7.0mm to 3.0mm*



312 06
cognac
cognac

312 07
mokka
mocha

312 13
schwarz
black

Länge Length (mm)		M	
Breite Width		114	82
Anstoß / Lug	Schließe / Buckle		
20 mm	18 mm	●	
22 mm	18 mm	▲	
22 mm	20 mm	▲	
24 mm	20 mm	◐	

Form Querschnitt | Cross-section:



»RUND« | »ROUND«

– Technische Angabe –
RIOS1931-Band, insbesondere
passend für Uhren der Marke
»Breitling«

– Technical specification –
RIOS1931 watch strap, particularly
suitable for watches of the brand
»Breitling«

DE: Alle aufgeführten Firmen, Marken und Kennzeichen sind Eigentum der jeweiligen Hersteller, bzw. Markeninhaber und dienen lediglich der Beschreibung.

ENG: All the listed companies, brands and symbols are the property of the respective manufacturer and/or brand owners and are for the descriptive purposes only.



Mod. 311 | Pilot

DE: *Echt Juchtenleder* | Für Faltschließe | »Art Manuel« |
Naht: *Cremeweiß* | Bandstärke: *ca. 7,0mm auf 2,5mm*

ENG: *Genuine Russia Leather* | For folding buckle | »Art Manuel« |
Seam: *cream white* | Thickness of strap: *approx. 7.0mm to 2.5mm*



311 06
cognac
cognac



311 07
mokka
mocha



311 13
schwarz
black

Länge Length (mm)		M	
		110	90
Breite Width			
Anstoß / Lug	Schließe / Buckle		
20 mm	18 mm	●	
22 mm	18 mm	▲	
22 mm	20 mm	▲	

Form Querschnitt | Cross-section:



»RUND« | »ROUND«

– Technische Angabe –
RIOS1931-Band, insbesondere
passend für Uhren der Marke
»Breitling«

– Technical specification –
RIOS1931 watch strap, particularly
suitable for watches of the brand
»Breitling«

DE: Alle aufgeführten Firmen, Marken und Kennzeichen sind Eigentum der jeweiligen Hersteller, bzw. Markeninhaber und dienen lediglich der Beschreibung.

ENG: All the listed companies, brands and symbols are the property of the respective manufacturer and/or brand owners and are for the descriptive purposes only.



Mod. 310 | Continental

DE: *Echt Haiischleder* | Für Faltschließe |
Naht: *Cremeweiß* | Bandstärke: *ca. 5,0mm auf 2,5mm*

ENG: *Genuine Shark Leather* | For folding buckle |
Seam: *cream white* | Thickness of strap: *approx. 5.0mm to 2.5mm*



310 12
ozeanblau
ocean blue



310 13
schwarz
black



310 23
royalblau
royal blue

Länge Length (mm)		M	
		110	90
Breite Width			
Anstoß / Lug	Schließe / Buckle		
20 mm	18 mm	●	
22 mm	18 mm	▲	

Form Querschnitt | Cross-section:



»ECKIG« | »SQUARE«

– Technische Angabe –
RIOS1931-Band, insbesondere
passend für Uhren der Marke
»Breitling«

– Technical specification –
RIOS1931 watch strap, particularly
suitable for watches of the brand
»Breitling«

DE: Alle aufgeführten Firmen, Marken und Kennzeichen sind Eigentum der jeweiligen Hersteller, bzw. Markeninhaber und dienen lediglich der Beschreibung.

ENG: All the listed companies, brands and symbols are the property of the respective manufacturer and/or brand owners and are for the descriptive purposes only.

Seite | Page 171
Mod. 598



Accessoires

Accessories



Mod. 599 | Juri

Kartenetui | Cardholder

DE: *Echt Alligatorenleder in matt, Flank | »Handnaht«* |

Naht: Cremeweiß | Länge: ca. 103 mm, Breite: ca. 83 mm, Höhe: ca. 4,5 mm

ENG: *Genuine Alligator Leather, matt finish, flank | »Saddler's Seam (Hand Seam)«* |

Seam: cream white | Length: approx. 103 mm, width: approx. 83 mm, height: approx. 4.5 mm



599 05
mahagoni
mahogany

599 06
cognac
cognac

599 07
mokka
mocha

599 12
ozeanblau
ocean blue

599 13
schwarz
black



Mod. 598 | Maxim

Kartenetui | Cardholder

DE: *Echt Alligatorenleder in matt, Flank | Naht: Ton in Ton | »Handnaht«* |

Länge: ca. 103 mm, Breite: ca. 83 mm, Höhe: ca. 4,5 mm

ENG: *Genuine Alligator Leather, matt finish, flank | »Saddler's Seam (Hand Seam)«* |

Seam: matching stitching | Length: approx. 103 mm, width: approx. 83 mm, height: approx. 4.5 mm



598 05
mahagoni
mahogany

598 06
cognac
cognac

598 07
mokka
mocha

598 12
ozeanblau
ocean blue

598 13
schwarz
black



Seite | Page 172
Mod. 597



– Jedes Etui ist ein Unikat –
Die Patina des Vintageleders kann stark unterschiedlich ausfallen.

– Every case is unique –
The patina of the vintage leather can strongly vary.

Mod. 597 | Iwan

Kartenetui | Cardholder

DE: *Echt Vintageleder | »Handnaht«* |

Naht: *Ton in Ton* | Länge: ca. 103mm, Breite: ca. 83mm, Höhe: ca. 4,5mm

ENG: *Genuine Vintage Leather | »Saddler's Seam (Hand Seam)«* |

Seam: *matching stitching* | Length: approx. 103mm, width: approx. 83mm, height: approx. 4.5mm



597 03
steingrau
stone grey

597 04
honig
honey

597 05
mahagoni
mahogany

597 06
cognac
cognac

597 07
mokka
mocha

597 13
schwarz
black



Mod. 596 Alexander
Kartenetui | Cardholder

DE: Alligatorenledernarbung auf echt Rindsleder geprägt, in matt | »Handnaht« |
Naht: Ton in Ton | Länge: ca. 103 mm, Breite: ca. 83 mm, Höhe: ca. 4,5 mm

ENG: Embossed Alligator Grain on Genuine Cow Leather, matt finish | »Saddler's Seam (Hand Seam)« |
Seam: matching stitching | Length: approx. 103 mm, width: approx. 83 mm, height: approx. 4.5 mm



596 06
cognac
cognac

596 07
mokka
mocha

596 13
schwarz
black



Mod. 595 Artur
Kartenetui | Cardholder

DE: Echt Büffelleleder | »Handnaht« |
Naht: Ton in Ton | Länge: ca. 103 mm, Breite: ca. 83 mm, Höhe: ca. 4,5 mm

ENG: Genuine Buffalo Leather | »Saddler's Seam (Hand Seam)« |
Seam: matching stitching | Length: approx. 103 mm, width: approx. 83 mm, height: approx. 4.5 mm



595 06
cognac
cognac

595 07
mokka
mocha

595 13
schwarz
black

Accessoires Accessories

Seite | Page 176
Mod. 579

Seite | Page 175
Mod. 586

Seite | Page 171
Mod. 598



[Mod. 589]

Georg

Schlüsselanhänger | Keyholder

DE: Echt Alligatorenleder in matt, Fullcut |

»Handnaht« | Naht: Cremeweiß |

Länge gesamt: ca. 87mm, Ø Ring: ca. 35mm

ENG: Genuine Alligator Leather, matt finish, fullcut |

»Saddler's Seam (Hand Seam)« | Seam: cream white |

Length overall: approx. 87mm, Ø ring: approx. 35mm



589 05
mahagoni
mahogany

589 06
cognac
cognac

589 07
mokka
mocha

589 13
schwarz
black



[Mod. 588]

Robert

Schlüsselanhänger | Keyholder

DE: Echt Alligatorenleder in matt, Flank |

»Handnaht« | Naht: Cremeweiß |

Länge gesamt: ca. 87mm, Ø Ring: ca. 35mm

ENG: Genuine Alligator Leather, matt finish, flank |

»Saddler's Seam (Hand Seam)« | Seam: cream white |

Length overall: approx. 87mm, Ø ring: approx. 35mm



588 05
mahagoni
mahogany

588 06
cognac
cognac

588 07
mokka
mocha

588 13
schwarz
black



[Mod. 587]

David

Schlüsselanhänger | Keyholder

DE: Echt Shell Cordovan Leder |

»Handnaht« | Naht: Cremeweiß |

Länge gesamt: ca. 87mm, Ø Ring: ca. 35mm

ENG: Genuine Shell Cordovan Leather |

»Saddler's Seam (Hand Seam)« | Seam: cream white |

Length overall: approx. 87mm, Ø ring: approx. 35mm



587 06
cognac
cognac

587 07
mokka
mocha

587 13
schwarz
black



[Mod. 586]

Adam

Schlüsselanhänger | Keyholder

DE: Echt Vintageleder |

»Handnaht« | Naht: Cremeweiß |

Länge gesamt: ca. 87mm, Ø Ring: ca. 35mm

ENG: Vintage Leather |

»Saddler's Seam (Hand Seam)« | Seam: cream white |

Length overall: approx. 87mm, Ø ring: approx. 35mm



586 02
sand
sand

586 05
mahagoni
mahogany

586 06
cognac
cognac

586 07
mokka
mocha

586 13
schwarz
black

– Jeder Schlüsselanhänger ist ein Unikat –
Die Patina des Vintageleders kann stark unterschiedlich ausfallen.

– Every Keyholder is unique –
The patina of the vintage leather can strongly vary.



Mod. 579 | **Carlo**

Uhrenreisemappe (für zwei Uhren) | Watch Travel Case (for two watches)

DE: *Echt Vintageleder* |

Naht: *Schwarz* | *Länge: ca. 215 mm, Breite: ca. 155 mm, Höhe: ca. 20 mm*

ENG: *Genuine Vintage Leather* |

Seam: *black* | *Length: approx. 215 mm, width: approx. 155 mm, height: approx. 20 mm*



579 **04**
honig
honey



579 **07**
mokka
mocha



579 **13**
schwarz
black

– *Jede Tasche ist ein Unikat* –
Die Patina des Vintageleders kann stark unterschiedlich ausfallen.

– *Every case is unique* –
The patina of the vintage leather can strongly vary.



Mod. 569 | **Julius**

Uhrenreisemappe (für eine Uhr) | Watch Travel Case (for one watch)

DE: *Echt Vintageleder* |

Naht: *Schwarz* | *Länge: ca. 170 mm, Breite: ca. 130 mm, Höhe: ca. 20 mm*

ENG: *Genuine Vintage Leather* |

Seam: *black* | *Length: approx. 170 mm, width: approx. 130 mm, height: approx. 20 mm*



569 **04**
honig
honey



569 **07**
mokka
mocha



569 **13**
schwarz
black

– *Jede Tasche ist ein Unikat* –
Die Patina des Vintageleders kann stark unterschiedlich ausfallen.

– *Every case is unique* –
The patina of the vintage leather can strongly vary.



– Jede Tasche ist ein Unikat –
Die Patina des Vintageleders kann stark unterschiedlich ausfallen.

– Every case is unique –
The patina of the vintage leather can strongly vary.

Mod. 559 | **Constantin**

Uhrentasche | Watch Wallet

DE: *Echt Vintageleder* |

Naht: *Ton in Ton* | Länge: ca. 175 mm, Breite: ca. 70 mm, Höhe: ca. 10 mm

ENG: *Genuine Vintage Leather* |

Seam: *matching stitching* | Length: approx. 175 mm, width: approx. 70 mm, height: approx. 10 mm



559 03
steingrau
stone grey

559 05
mahagoni
mahogany

559 06
cognac
cognac

559 07
mokka
mocha

559 13
schwarz
black



Mod. 549 | **Leonardo**

Uhrenbeutel | Watch Bag

DE: *Echt Lammleder* |

Naht: *Ton in Ton* | Länge: ca. 180 mm, Breite: ca. 80 mm, Höhe: ca. 1,8 mm

ENG: *Genuine Lambskin* |

Seam: *matching stitching* | Length: approx. 180 mm, width: approx. 80 mm, height: approx. 1.8 mm



549 03
steingrau
stone grey

549 06
cognac
cognac

549 07
mokka
mocha

549 12
ozeanblau
ocean blue

549 13
schwarz
black

RIOS 1931

Präsentation

Presentation

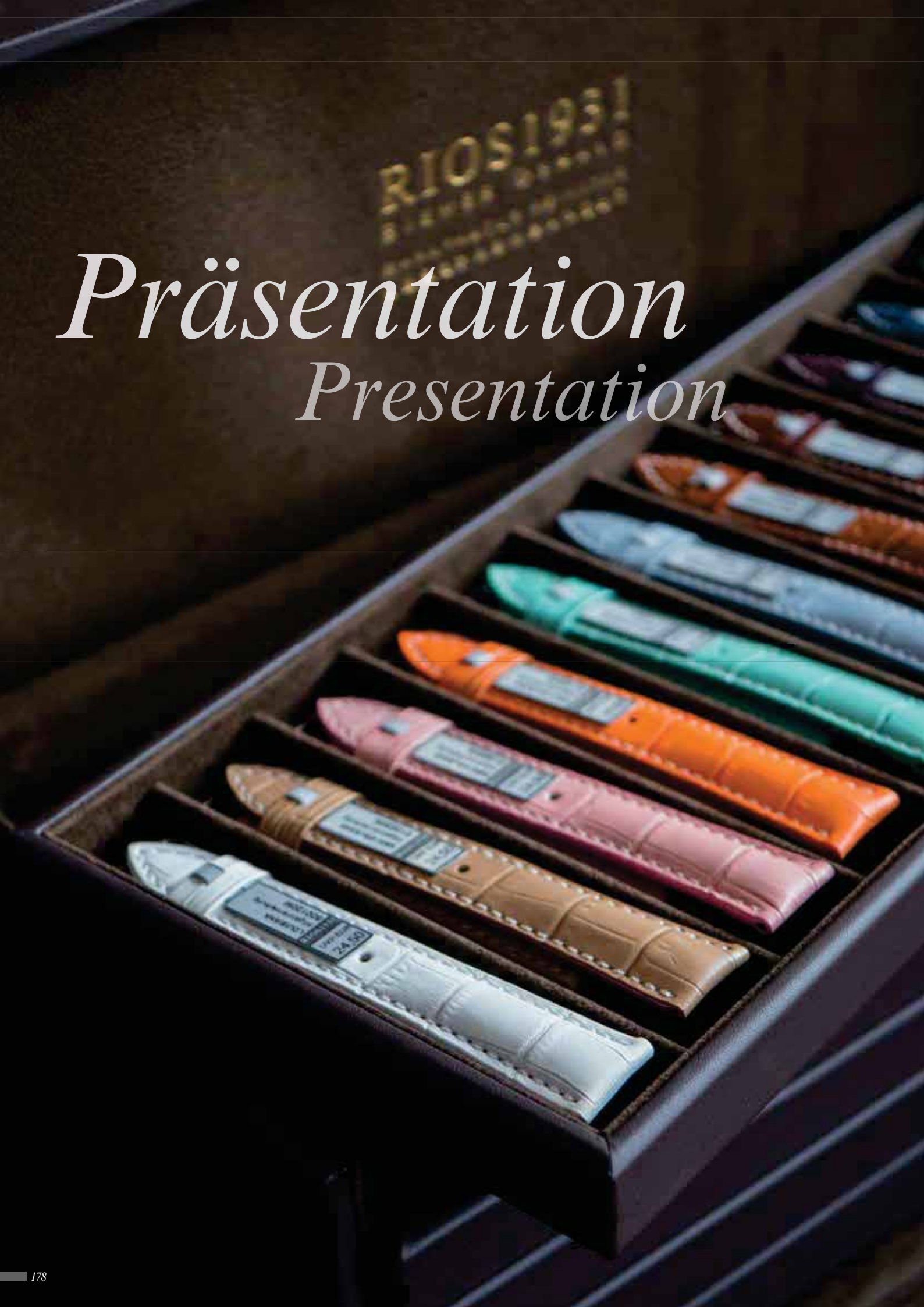



|Mod. **1350**|

Intelligence 300

Verkaufsständer | Display Stand

DE: Verkaufsständer mit Schubladensystem |
13 Vorlagetablets für je 22 Armbänder | Bis maximal 326 Armbänder
(Abbildung ähnlich, ohne Inhalt)

ENG: Display rack with drawer system |
13 trays for 22 watch straps each | To a maximum of 326 watch straps
(Photo similar to original object, pictured contents not included)

Länge: ca. 380mm, Breite: ca. 380mm, Höhe: ca. 380mm
Length: approx. 380mm, width: approx. 380mm, height: approx. 380mm

|Mod. **1351**|

Intelligence 300

Unterständer | Display System

DE: Unterständer, abschließbar mit zwei Fächern | Mit vier Rollen
(Abbildung ähnlich, ohne Inhalt)

ENG: Lockable cabinet with two compartments | With 4 wheels
(Picture similar to original object; pictured contents not included)

Länge: ca. 380mm, Breite: ca. 380mm, Höhe: ca. 900mm
Length: approx. 380mm, width: approx. 380mm, height: approx. 900mm





[Mod. 1221]

Talent

Verkaufsbox | Display Box

DE: Kunstleder mit fünf Vorlagetabletts für insgesamt 52 Armbänder | Vier Tablettts für je elf Armbänder | Ein Tablett für je acht Armbänder (Abbildung ähnlich, ohne Inhalt)

ENG: Synthetic leather with 5 trays for a total of 52 watch straps | 4 trays each for 11 watch straps | 1 tray for 8 watch straps (Photo similar to original object, pictured contents not included)

Länge: ca. 345 mm, Breite: ca. 100 mm, Höhe: ca. 130 mm

Length: approx. 345mm, width: approx. 100mm, height: approx. 130mm



[Mod. 1220]

Competence

Verkaufsbox | Display Box

DE: Aus edlem lackierten Echtholz für insgesamt 27 Armbänder | Drei Vorlagetabletts für je neun Armbänder (Abbildung ähnlich, ohne Inhalt)

ENG: Elegant lacquered wood box for a total of 27 watch straps | 3 trays for 9 watch straps each (Photo similar to original object, pictured contents not included)

Länge: ca. 305 mm, Breite: ca. 190 mm, Höhe: ca. 90 mm

Length: approx. 305mm, width: approx. 190mm, height: approx. 90mm



|Mod. 1210|

Genius

Vorlegemappe (ohne Karten) | Presentation Folder (without cards)

DE: Zwei Seiten für acht Karten für insgesamt ca. 80 Armbänder
(Abbildung ähnlich, ohne Inhalt)

ENG: 2 pages holding 8 cards for a total approx. 80 watch straps
(Photo similar to original object, pictured contents not included)

Geschlossen - Länge: ca. 270mm, Breite: ca. 170mm, Höhe: ca. 100mm

Offen - Länge: ca. 270mm, Breite: ca. 850mm, Höhe: ca. 30mm

Closed - length: approx. 270mm, width: approx. 170mm, height: approx. 100mm

Open - length: approx. 270mm, width: approx. 850mm, height: approx. 30mm



|Mod. 1200|

Aufsteckkarte | Inserting Cards

DE: In verschiedenen Variationen, Längen und Breiten
(Abbildung ähnlich)

ENG: In different varieties, lengths and widths.
(Photo similar to original object)

Länge: ca. 250mm, Breite: ca. 150mm, Höhe: ca. 5mm

Length: approx. 250mm, width: approx. 150mm, height: approx. 5mm

Dornschnießen

Pin buckles

Abbildungen ähnlich | Photo similar to original object



[Mod. 1131]

Canada

»Schwarz« (matt)
»Black« (matt finish)

DE: Dornschniße |
Massive Ausführung: Edelstahl

ENG: Pin buckle |
Solid finish: Stainless steel

Breiten: 22 mm, 24 mm
Widths: 22 mm, 24 mm



[Mod. 1130]

Canada

»Stahl« (gehämmert, matt)
»Steel« (hammered, matt finish)

DE: Dornschniße |
Massive Ausführung: Edelstahl

ENG: Pin buckle |
Solid finish: Stainless steel

Breiten: 22 mm, 24 mm
Widths: 22 mm, 24 mm



DE: Die entsprechend gekennzeichneten Bänder im Katalog werden ohne Schnießen geliefert - auf diesen beiden Seite können Sie aus dafür besonders geeigneten Modellen wählen.

ENG: On these two pages you will find clasp types suitable for the watch straps in the catalogue indicated as being supplied without a clasp.

Abbildungen ähnlich | Photo similar to original object



|Mod. 1123|

Italy

»Schwarz« (matt)
»Black« (matt finish)

DE: DornschnlieÙe |
Massive Ausföhrung: Edelstahl

ENG: Pin buckle |
Solid finish: Stainless steel

Breiten: 16 mm, 18 mm, 20 mm
22 mm, 24 mm

Widths: 16 mm, 18 mm, 20 mm
22 mm, 24 mm



|Mod. 1122|

Italy

»Stahl« (gebürstet)
»Steel« (brushed)

DE: DornschnlieÙe |
Massive Ausföhrung: Edelstahl

ENG: Pin buckle |
Solid finish: Stainless steel

Breiten: 16 mm, 18 mm, 20 mm
22 mm, 24 mm

Widths: 16 mm, 18 mm, 20 mm
22 mm, 24 mm



|Mod. 1121|

Italy

»Golden« (glänzend)
»Golden« (glossy finish)

DE: DornschnlieÙe |
Massive Ausföhrung: Edelstahl,
goldfarben

ENG: Pin buckle |
Solid finish: Stainless steel,
golden coloured

Breiten: 16 mm, 18 mm, 20 mm
22 mm, 24 mm

Widths: 16 mm, 18 mm, 20 mm
22 mm, 24 mm



|Mod. 1120|

Italy

»Stahl« (glänzend)
»Steel« (glossy finish)

DE: DornschnlieÙe |
Massive Ausföhrung: Edelstahl

ENG: Pin buckle |
Solid finish: Stainless steel

Breiten: 16 mm, 18 mm, 20 mm
22 mm, 24 mm

Widths: 16 mm, 18 mm, 20 mm
22 mm, 24 mm



|Mod. 1113|

USA

»Schwarz« (matt)
»Black« (matt finish)

DE: DornschnlieÙe mit
Schraubsteg |
Massive Ausföhrung: Edelstahl

ENG: Pin buckle with
turnable pin |
Solid finish: Stainless steel

Breiten: 20 mm, 22 mm, 24 mm, 26 mm
Widths: 20 mm, 22 mm, 24 mm, 26 mm



|Mod. 1111|

USA

»Stahl« (gebürstet)
»Steel« (brushed)

DE: DornschnlieÙe mit
Schraubsteg |
Massive Ausföhrung: Edelstahl

ENG: Pin buckle with
turnable pin |
Solid finish: Stainless steel

Breiten: 20 mm, 22 mm, 24 mm, 26 mm
Widths: 20 mm, 22 mm, 24 mm, 26 mm



|Mod. 1110|

USA

»Stahl« (glänzend)
»Steel« (glossy finish)

DE: DornschnlieÙe mit
Schraubsteg |
Massive Ausföhrung: Edelstahl

ENG: Pin buckle with
turnable pin |
Solid finish: Stainless steel

Breiten: 20 mm, 22 mm, 24 mm, 26 mm
Widths: 20 mm, 22 mm, 24 mm, 26 mm

Abbildungen ähnlich | Photo similar to original object

Abbildungen ähnlich | Photo similar to original object



|Mod. 1180|
Werkzeug | Tool

DE: Zum Tauschen von
Federstegen, Stahl

ENG: To replace pin, steel



|Mod. 1170|
Lochzange | Hole punch

DE: Lochzange für Wechsel-
Federstege

ENG: Punch for punching holes
for replacement pins



|Mod. 1160|
**Wechsel-Federsteg |
Interchangeable pin**

DE: Edelstahl

ENG: Stainless steel



|Mod. 1150|
Federsteg | Pin

DE: Edelstahl

ENG: Stainless steel

Breiten: 14 mm, 16 mm, 18 mm, 20 mm,
22 mm, 24 mm

Widths: 14 mm, 16 mm, 18 mm, 20 mm,
22 mm, 24 mm

Breiten: 10 mm, 12 mm, 14 mm, 16 mm,
18 mm, 19 mm, 20 mm, 22 mm

Widths: 10 mm, 12 mm, 14 mm, 16 mm,
18 mm, 19 mm, 20 mm, 22 mm



|Mod. 1700|
Katalog | Catalogue

|Mod. 1500|
Preisetikett | Price label



Abbildungen ähnlich | Photo similar to original object



[Mod. 1109]

Austria

»Stahl« (glänzend)
»Steel« (glossy finish)

DE: Roll-Dornschließe |
Ausführung: Edelstahl

ENG: Roll buckle |
Finish: Stainless steel

Breiten: 18 mm, 20 mm
Widths: 18 mm, 20 mm

[Mod. 1107]

France

»Golden« (glänzend)
»Golden« (glossy finish)

DE: Dornschließe |
Ausführung: Edelstahl,
goldfarben

ENG: Pin buckle |
Finish: Stainless steel,
golden coloured

Breiten: 16 mm, 18 mm, 20 mm
Widths: 16 mm, 18 mm, 20 mm

[Mod. 1106]

France

»Stahl« (glänzend)
»Steel« (glossy finish)

DE: Dornschließe |
Ausführung: Edelstahl

ENG: Pin buckle |
Finish: Stainless steel

Breiten: 16 mm, 18 mm, 20 mm
Widths: 16 mm, 18 mm, 20 mm

[Mod. 1105]

Japan

»Titan« (matt)
»Titan« (matt finish)

DE: Dornschließe |
Ausführung: Titan

ENG: Pin buckle |
Finish: Titanium

Breiten: 10 mm, 12 mm, 14 mm,
16 mm, 18 mm
Widths: 10 mm, 12 mm, 14 mm,
16 mm, 18 mm

Abbildungen ähnlich | Photo similar to original object



[Mod. 1102]

RIOS1931 Standard

»Rosé« (glänzend)
»Rosé« (glossy finish)

DE: Dornschließe |
Teils mit RIOS1931-Logo |
Ausführung: Edelstahl,
rosé-goldfarben

ENG: Pin buckle |
Partly with RIOS1931 logo |
Finish: Stainless steel,
rosé golden coloured

Breiten: 16 mm, 18 mm, 20 mm
Widths: 16 mm, 18 mm, 20 mm

[Mod. 1101]

RIOS1931 Standard

»Golden« (glänzend)
»Golden« (glossy finish)

DE: Dornschließe |
Teils mit RIOS1931-Logo |
Ausführung: Edelstahl,
goldfarben

ENG: Pin buckle |
Partly with RIOS1931 logo |
Finish: Stainless steel,
golden coloured

Breiten | Widths: 06 mm, 08 mm,
10 mm, 12 mm, 14 mm, 16 mm, 18 mm,
20 mm, 22 mm, 24 mm, 26 mm, 28 mm

[Mod. 1100]

RIOS1931 Standard

»Stahl« (glänzend)
»Steel« (glossy finish)

DE: Dornschließe |
Teils mit RIOS1931-Logo |
Ausführung: Edelstahl

ENG: Pin buckle |
Partly with RIOS1931 logo |
Finish: Stainless steel

Breiten | Widths: 06 mm, 08 mm,
10 mm, 12 mm, 14 mm, 16 mm, 18 mm,
20 mm, 22 mm, 24 mm, 26 mm, 28 mm

Faltschließen Folding buckles

Abbildungen ähnlich | Photo similar to original object

– Technische Angabe –
Insbesondere passend für Uhren
der Marke »Breitling«

– Technical specification –
Particularly suitable for watches
of the brand »Breitling«



[Mod. 1020]

Aircraft

»Stahl« (glänzend)
»Steel« (glossy finish)

DE: Faltschließe |
Ausführung: Edelstahl

ENG: Folding buckle |
Finish: Stainless steel

Breiten: 18 mm, 20 mm
Widths: 18 mm, 20 mm



[Mod. 1010]

Swiss

»Stahl« (glänzend)
»Steel« (glossy finish)

DE: Faltschließe mit Pusher |
Öffnungssystem: »Butterfly« |
Ausführung: Edelstahl

ENG: Folding buckle with pusher |
Opening system: »Butterfly« |
Finish: Stainless steel

Breiten: 16 mm, 18 mm, 20 mm, 22 mm
Widths: 16 mm, 18 mm, 20 mm, 22 mm

DE: Alle aufgeführten Firmen, Marken und Kennzeichen sind Eigentum der jeweiligen Hersteller, bzw. Markeninhaber und dienen lediglich der Beschreibung.

ENG: All the listed companies, brands and symbols are the property of the respective manufacturer and/or brand owners and are for the descriptive purposes only.

Abbildungen ähnlich | Photo similar to original object



[Mod. 1006]

Germany

»Rosé« (beschichtet | gebürstet)
»Rosé« (coated | brushed)

DE: Faltschließe mit Pusher |
Öffnungssystem: »Butterfly« |
Ausführung: Edelstahl,
rosé-goldfarben

ENG: Folding buckle with pusher |
Opening system: »Butterfly« |
Finish: Stainless steel,
rosé golden coloured

Breiten: 16 mm, 18 mm, 20 mm
Widths: 16 mm, 18 mm, 20 mm



[Mod. 1005]

Germany

»Golden« (gebürstet)
»Golden« (brushed)

DE: Faltschließe mit Pusher |
Öffnungssystem: »Butterfly« |
Ausführung: Edelstahl,
goldfarben

ENG: Folding buckle with pusher |
Opening system: »Butterfly« |
Finish: Stainless steel,
golden coloured

Breiten: 16 mm, 18 mm, 20 mm
Widths: 16 mm, 18 mm, 20 mm



[Mod. 1004]

Germany

»Stahl« (gebürstet)
»Steel« (brushed)

DE: Faltschließe mit Pusher |
Öffnungssystem: »Butterfly« |
Ausführung: Edelstahl

ENG: Folding buckle with pusher |
Opening system: »Butterfly« |
Finish: Stainless steel

Breiten: 16 mm, 18 mm, 20 mm
Widths: 16 mm, 18 mm, 20 mm



[Mod. 1003]

Germany

»Schwarz« (glänzend)
»Black« (glossy finish)

DE: Faltschließe mit Pusher |
Öffnungssystem: »Butterfly« |
Ausführung: Edelstahl

ENG: Folding buckle with pusher |
Opening system: »Butterfly« |
Finish: Stainless steel

Breiten: 16 mm, 18 mm, 20 mm
Widths: 16 mm, 18 mm, 20 mm



[Mod. 1002]

Germany

»Rosé« (beschichtet | glänzend)
»Rosé« (coated | glossy finish)

DE: Faltschließe mit Pusher |
Öffnungssystem: »Butterfly« |
Ausführung: Edelstahl,
rosé-goldfarben

ENG: Folding buckle with pusher |
Opening system: »Butterfly« |
Finish: Stainless steel,
rosé golden coloured

Breiten: 16 mm, 18 mm, 20 mm
Widths: 16 mm, 18 mm, 20 mm



[Mod. 1001]

Germany

»Golden« (glänzend)
»Golden« (glossy finish)

DE: Faltschließe mit Pusher |
Öffnungssystem: »Butterfly« |
Ausführung: Edelstahl,
goldfarben

ENG: Folding buckle with pusher |
Opening system: »Butterfly« |
Finish: Stainless steel,
golden coloured

Breiten: 16 mm, 18 mm, 20 mm
Widths: 16 mm, 18 mm, 20 mm



[Mod. 1000]

Germany

»Stahl« (glänzend)
»Steel« (glossy finish)

DE: Faltschließe mit Pusher |
Öffnungssystem: »Butterfly« |
Ausführung: Edelstahl

ENG: Folding buckle with pusher |
Opening system: »Butterfly« |
Finish: Stainless steel

Breiten: 16 mm, 18 mm, 20 mm
Widths: 16 mm, 18 mm, 20 mm

Abbildungen ähnlich | Photo similar to original object

Farbübersicht Echt Alligator | Colour Palette Genuine Alligator



| 01 |
weiß
white

| 09 |
rosa
pale pink

| 22 |
pink
pink

| 21 |
flieder
lilac

| 25 |
lila
purple

| 19 |
eisblau
ice blue

| 17 |
türkis
turquoise

| 03 |
steingrau
stone grey

| 23 |
royalblau
royal blue

| 02 |
sand
sand

| 16 |
gelb
yellow

| 04 |
honig
honey

| 14 |
orange
orange

| 08 |
rot
red

| 11 |
bordeaux
burgundy

| 27 |
taupe
taupe

| 10 |
forstgrün
forest green

| 29 |
tabak
tobacco

| 30 |
graphit
graphite





RIOS1931 Farben

RIOS1931 Colours



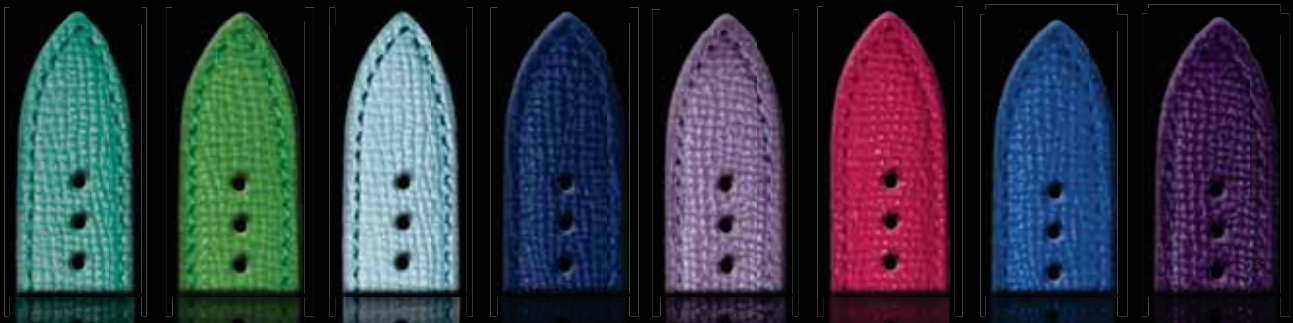

| 17 |
türkis
turquoise

| 18 |
apfelgrün
apple green

| 19 |
eisblau
ice blue

| 20 |
marineblau
navy

| 21 |
flieder
lilac

| 22 |
pink
pink

| 23 |
royalblau
royal blue

| 25 |
lila
purple



| 26 |
kaschmir
cashmere

| 27 |
taupe
taupe

| 28 |
rubinrot
ruby

| 29 |
tabak
tobacco

| 30 |
graphit
graphite

| 24 |
schwarz/orange Naht
black/orange stitching



So finden Sie die Artikelnummer zu Ihrem Uhrenarmband How to find the article number for your watch strap

Bestellnummer | Order number:

50 13 20 / 18 M



Modell | Model:
LOUISIANA



Farbe | Colour:
schwarz | black

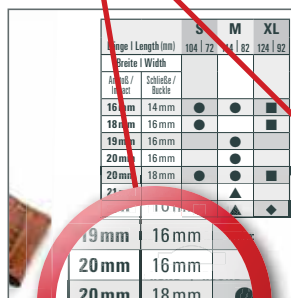

Breite | Width:
20 / 18mm

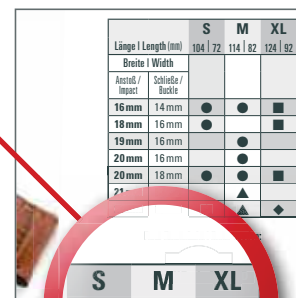

Länge | Length:
114 / 82mm

Erklärung zum Etikett | Explanation of the label



DE: Die in diesem Katalog abgebildeten Fotos sind urheberrechtlich geschützt. Sie dürfen nur mit Genehmigung der Firma RIOS1931, Oswald Riemer, Uhrenarmbandfabrik GmbH, Willibald-Popp-Straße 2, 86179 Augsburg / Germany reproduziert, kopiert oder in anderer Weise genutzt werden. Nachdruck nur mit ausdrücklicher Genehmigung.

Leder ist ein Naturprodukt. Farbabweichungen sind deshalb nicht auszuschließen und begründen keinen Mangel.

Die angegebenen Bandstärken beziehen sich auf die Bandbreite 20mm.
Die Bandstärke wird auf die Bandbreite abgestimmt und kann variieren.

Um Toleranzen am Uhrengehäuse auszugleichen und eine lebenslange Passgenauigkeit zu gewährleisten, wird jedes RIOS1931-Uhrenarmband + 0,2 mm bis 0,3 mm breiter gefertigt.

ENG: The images in this catalogue are protected by copyright. They may only be reproduced, copied or used in any way with permission of the company RIOS1931, Oswald Riemer, Uhrenarmbandfabrik GmbH, Willibald-Popp-Straße 2, 86179 Augsburg / Germany. Any reproduction requires express permission.

Leather is a natural product colour deviations cannot be excluded and do not constitute a defect.

The specified watch strap thicknesses correspond to a strap width of 20mm.
The thickness of the strap is determined by its width and may vary.

To compensate for tolerances on the watch casing and to ensure lifelong accuracy of fit each RIOS1931 watch strap is made + 0.2 mm to 0.3 mm wider.

Einhängesystem

Easy clasp system



RIOS1931

– Spangenband –

*Schnelles und einfaches Wechseln durch das Spangensystem.
Der Federsteg muss nicht ausgebaut werden.*



RIOS1931

– Clasp strap –

*A fast and easy system to change the clasp.
The pin does not have to be removed.*



RIOS1931 - Oswald Riemer
Uhrenarmbandfabrik GmbH

Willibald-Popp-Straße 2
86179 Augsburg/Germany

Bestellung: 0821 8152907
Telefon: 0821 811020
Telefax: 0821 813946

Orders: + 49 (0)821 8152907
Phone: + 49 (0)821 811020
Fax: + 49 (0)821 813946

Bestellung: verkauf@RIOS1931.de
Info & Kontakt: info@RIOS1931.de
Buchhaltung: verwaltung@RIOS1931.de
Sachbearbeitung: sachbearbeitung@RIOS1931.de

Orders: sales@RIOS1931.de
Info & Contact: info@RIOS1931.de
Accounts Dept.: administration@RIOS1931.de
Administration Dept.: processing@RIOS1931.de



Stand: Januar 2018 / Katalog gültig bis auf Widerruf | Status: Januar 2018 / Catalogue valid until recalled
Irrtümer und Druckfehler vorbehalten | Mistakes and misprints are subjected to change

www.RIOS1931.de